

A Comparative Study of Some Central Notions of ASPIC⁺ and DeLP

ALEJANDRO J. GARCÍA

*Institute for Computer Science and Engineering (CONICET-UNS),
Department of Computer Science & Engineering,
Universidad Nacional del Sur, Bahía Blanca, Argentina
(e-mail: ajg@cs.uns.edu.ar)*

HENRY PRAKKEN

*Department of Information and Computing Sciences,
Utrecht University & Faculty of Law,
University of Groningen,
Utrecht & Groningen, The Netherlands
(e-mail: h.praakken@uu.nl)*

GUILLERMO R. SIMARI

*Institute for Computer Science and Engineering (CONICET-UNS),
Department of Computer Science & Engineering,
Universidad Nacional del Sur, Bahía Blanca, Argentina
(e-mail: grs@cs.uns.edu.ar)*

submitted 18 December 2018; revised 10 September 2019; accepted 10 September 2019

Abstract

This paper formally compares some central notions from two well-known formalisms for rule-based argumentation, *DeLP* and *ASPIC⁺*. The comparisons especially focus on intuitive adequacy and inter-translatability, consistency, and closure properties. As for differences in the definitions of arguments and attack, it turns out that *DeLP*'s definitions are intuitively appealing but that they may not fully comply with Caminada and Amgoud's rationality postulates of strict closure and indirect consistency. For some special cases, the *DeLP* definitions are shown to fare better than *ASPIC⁺*. Next, it is argued that there are reasons to consider a variant of *DeLP* with grounded semantics, since in some examples its current notion of warrant arguably has counterintuitive consequences and may lead to sets of warranted arguments that are not admissible. Finally, under some minimality and consistency assumptions on *ASPIC⁺* arguments, a one-to-many correspondence between *ASPIC⁺* arguments and *DeLP* arguments is identified in such a way that if the *DeLP* warranting procedure is changed to grounded semantics, then *DeLP*'s notion of warrant and *ASPIC⁺*'s notion of justification are equivalent. This result is proven for three alternative definitions of attack.

KEYWORDS: rule-based argumentation, defeasible logic programming, *ASPIC⁺*

1 Introduction

ASPIC⁺ (Prakken 2010) and defeasible logic programming, or *DeLP* for short (García and Simari 2004), are two well-known rule-based formalisms for argumentation. “Rule-based” is not about expressiveness but about how arguments are constructed. In a rule-

based approach¹, arguments are formed by chaining applications of inference rules into inference trees or graphs. This approach can be contrasted with approaches defined in terms of logical consequence notions, in which arguments are premises–conclusion pairs where the premises are consistent and imply the conclusion according to the consequence notion of some adopted “base logic.” Examples of this approach are classical-logic argumentation (Cayrol 1995; Besnard and Hunter 2001, 2008; Gorogiannis and Hunter 2011) and its generalization into abstract Tarskian-logic argumentation (Amgoud and Besnard 2013). It is important to note that, unlike these logic-based approaches, rule-based approaches in general do not adopt a single base logic but two base logics, one for the strict and one for the defeasible rules.

ASPIC⁺ and *DeLP* are similar in various respects: both have a distinction between strict and defeasible inference rules and both use preferences to resolve attacks into defeats. The shared rule-based approach and these further similarities warrant a detailed comparison between the two frameworks. Such a comparison is the topic of this paper. It will turn out that there are also differences, the main one being that while *ASPIC⁺* evaluates arguments with the by now standard Dungean semantics of abstract argumentation frameworks (*AFs*) (Dung 1995), *DeLP* has a special-purpose definition of argument evaluation. Both of *ASPIC⁺* and of *DeLP* various versions exist. As for *DeLP*, we will discuss the version introduced by García and Simari (2004), which arguably is the standard version. As for *ASPIC⁺*, we will unless indicated otherwise assume the version of Modgil and Prakken (2013) with defeat-conflict-freeness, no consistency constraints on premise sets, and the contrariness relation corresponding to “strong” or “symmetric” negation.

We will compare *DeLP* 2004 with *ASPIC⁺* 2013, and we will also study modifications of both systems with ideas from the other systems. In particular, we will consider a version of *DeLP* with grounded semantics and a version of *ASPIC⁺* with *DeLP*’s notion of rebutting attack, either with or without *DeLP*’s consistency constraints on arguments. Just before this paper was finished, we learned that Parsons and Cohen (2018) had also carried out a comparison between *ASPIC⁺* and *DeLP*. Nevertheless, our investigation can be regarded as complementary to theirs. In their work, they seek to revisit aspects that differentiate *DeLP* from *ASPIC⁺*, analyze the common ground between the two approaches, and study the possibility of establishing conditions that would help bridge the gap between them. The discussion mainly centers on the similarities and differences between *ASPIC⁺* and *DeLP* regarding knowledge representation capabilities, the mechanism adopted for argument construction, and the different types of attack and defeat they consider. Their focus is not on formally proving properties of or relations between the two formalisms.

To summarize our main findings, as for differences in the definitions of arguments and attack, it will turn out that *DeLP*’s definitions are intuitively appealing and in some special cases the *DeLP* definitions will be shown to fare better than *ASPIC⁺*. On the other hand, the *DeLP* definitions may not fully comply with the rationality postulates of strict closure and indirect consistency introduced by Caminada and Amgoud (2007). In Section 4.1, we will include a thorough discussion about these issues. As we will discuss in Section 6, while the *DeLP* definition of warrant is similar to grounded semantics, there are also differences, caused by the fact that the constraints on the

¹ This and some other fragments in this paper are taken (or adapted) from Modgil and Prakken (2018).

argument evaluation do not coincide with the constraints on games in the game-theoretic proof theory for grounded semantics. For these reasons, we will introduce a special version of *DeLP* under grounded semantics, since in some examples its current notion of warrant arguably has counterintuitive consequences and may lead to sets of warranted arguments that are not admissible under Dung's definition. Finally, under some minimality and consistency assumptions on *ASPIC*⁺ arguments, a one-to-many correspondence between *ASPIC*⁺ arguments and *DeLP* arguments will be identified in such a way that if the *DeLP* warranting procedure is changed to grounded semantics, then *DeLP*'s notion of warrant and *ASPIC*⁺'s notion of justification are equivalent. This result will be proven for three alternative definitions of attack.

This paper is organized as follows. We start with a brief sketch of the history of both frameworks in Section 2 and a summary of the formalisms in Section 3. We then compare the argument and attack definitions of the two formalisms in Sections 4 and 5. We will argue that *DeLP*'s definitions are interesting alternatives to *ASPIC*⁺ definitions which in some special cases represent possible improvements. Then in Section 6, we compare the different ways in which *ASPIC*⁺ and *DeLP* evaluate arguments. We will argue that some differences reveal possible drawbacks of the *DeLP* semantics. After observing that the motivation behind *DeLP*'s semantics is similar to the intuitions underlying (Dung's 1995) grounded semantics, we propose a version of *DeLP* with grounded semantics, arguing that all the examples given by García and Simari (2004) as reasons for their special semantics are treated as they want by grounded semantics. Finally, in Section 7, we prove correspondence results with respect to arguments, attacks, defeats, and extensions between *ASPIC*⁺ and *DeLP*.

2 History

ASPIC⁺ originated from the European *ASPIC* project as an attempt to integrate and consolidate the then state of the art in formal argumentation (see Amgoud et al. 2006). It was, in particular, inspired by the research of Pollock (1987, 1995), and Vreeswijk (1997). A basic version without preferences or premise attack was used by Caminada and Amgoud (2007) as a vehicle for introducing and studying various so-called rationality postulates for argumentation. Prakken (2010) introduced the first full version of *ASPIC*⁺, introducing premise attack and preferences. Since then the framework has been further developed and studied in several publications. For a detailed overview, see Section 5 of Modgil and Prakken (2018). In consequence, *ASPIC*⁺ as it has been developed over the years is not a single framework but a family of frameworks varying on several elements.

DeLP was developed on the basis of Simari and Loui (1992), who presented a rule-based argumentation system with both strict and defeasible inference rules, with specificity as a means to resolve attacks and with an argument evaluation definition taken from Pollock (1987), which was later by Dung (1995) shown to be equivalent to his grounded semantics. Inspired by this work, *DeLP* was developed in a series of papers, culminating in García and Simari (2004), which is now regarded as the standard paper on *DeLP*. The idea of argument evaluation in terms of a dialectical tree, now typical for *DeLP*, was introduced by García et al. (1993) and Simari et al. (1994b). The first paper establishing conditions on the construction of the branches of a dialectical tree (called an argumentation line) was García et al. (1998); thus, this was the paper that gave up grounded semantics for *DeLP*.

3 Formal Preliminaries

In this section, we summarize the formal systems used throughout the paper. More details can be found in the papers already mentioned above and in Baroni *et al.* (2011, 2018) for abstract *AFs*, Modgil and Prakken (2014, 2018) for *ASPIC⁺*, and García and Simari (2014, 2018) for *DeLP*. It is relevant at this point to remark that the presentations of *ASPIC⁺* and *DeLP* contained in this paper heavily rely on earlier presentations of these systems, such as the ones cited.

3.1 Abstract argumentation frameworks

An *abstract argumentation framework (AF)* is a pair $\langle \mathcal{A}, \text{attack} \rangle$, where \mathcal{A} is a set of arguments and $\text{attack} \subseteq \mathcal{A} \times \mathcal{A}$. The theory of *AFs* (Dung 1995) identifies sets of arguments (called *extensions*) which are internally coherent and defend themselves against attack. An argument $A \in \mathcal{A}$ is *defended* by a set by $S \subseteq \mathcal{A}$ if for all $B \in \mathcal{A}$: if B attacks A , then some $C \in S$ attacks B . A set S of arguments is *conflict-free* if no argument in S attacks an argument in S . Then, relative to a given *AF*,

- E is *admissible* if E is conflict-free and defends all its members;
- E is a *complete extension* if E is admissible and $A \in E$ iff A is defended by E ;
- E is a *preferred extension* if E is a \subseteq -maximal admissible set;
- E is a *stable extension* if E is admissible and attacks all arguments outside it;
- $E \subseteq \mathcal{A}$ is the *grounded extension* if E is the least fixpoint of operator F , where $F(S)$ returns all arguments defended by S .

Finally, for $T \in \{\text{complete, preferred, grounded, stable}\}$, X is *sceptically* or *credulously* justified under the T semantics if X belongs to all, respectively at least one, T extension.

In *ASPIC⁺*, the attack relation is renamed to *defeat* to distinguish it from a more basic notion of conflict between arguments, which in *ASPIC⁺* is called attack. Moreover, the following terminology is used. Argument A *strictly defeats* argument B if A defeats B and B does not defeat A . Argument A *weakly defeats* argument B if A defeats B and B defeats A .

In the comparisons between *ASPIC⁺* and *DeLP*, we will use grounded semantics. In particular, we will use the following game-theoretic proof theory, which is sound and complete with respect to grounded semantics (Prakken 1999; Modgil and Caminada 2009).

Definition 1

An *argument game* for grounded semantics is a finite nonempty sequence of moves $\text{move}_i = (\text{Player}_i, \text{Arg}_i)$ ($i > 0$), such that

1. $\text{Player}_i = P$ iff i is odd; and $\text{Player}_i = O$ iff i is even;
2. If $\text{Player}_i = \text{Player}_j = P$ and $i \neq j$, then $\text{Arg}_i \neq \text{Arg}_j$;
3. If $\text{Player}_i = P$, then Arg_i strictly defeats Arg_{i-1} ;
4. If $\text{Player}_i = O$, then Arg_i defeats Arg_{i-1} .

The first condition says that the proponent begins and then the players take turns, while the second condition prevents the proponent from repeating its attacks. The last two conditions form the heart of the definition: they state the burdens of proof for P and O .

The non-repetition rule and the condition that P moves strict defeaters (as opposed to O being allowed to move any defeater) are not needed for soundness and completeness but they make many otherwise infinite games finite.

Definition 2

A player *wins an argument game* iff the other player cannot move. An argument A is *provably justified* iff the proponent has a winning strategy in a game beginning with A .

As is well-known, a strategy for the proponent can be displayed as a tree of games which only branches after the proponent's moves and which then contains all defeaters of this move. A strategy for the proponent is then winning if all games in the tree end with a move by the proponent. We will use these observations below in comparing the grounded argument game with *DeLP*'s dialectical trees.

3.2 ASPIC⁺

We next specify the present paper's instance of the *ASPIC*⁺ framework. It defines abstract argumentation systems as structures consisting of a logical language \mathcal{L} with symmetric negation and two sets \mathcal{R}_s and \mathcal{R}_d of strict and defeasible inference rules defined over \mathcal{L} . In the present paper, \mathcal{L} is a language of propositional or predicate-logic literals, since this is also the language assumed by *DeLP*. Arguments are constructed from a knowledge base (a subset of \mathcal{L}) by combining inferences over \mathcal{L} . Formally:

Definition 3 (Argumentation System)

An *argumentation system* (AS) is a pair $AS = (\mathcal{L}, \mathcal{R})$ where:

- \mathcal{L} is a logical language consisting of propositional or ground predicate-logic literals
- $\mathcal{R} = \mathcal{R}_s \cup \mathcal{R}_d$ is a set of strict (\mathcal{R}_s) and defeasible (\mathcal{R}_d) inference rules of the form $\{\varphi_1, \dots, \varphi_n\} \rightarrow \varphi$ and $\{\varphi_1, \dots, \varphi_n\} \Rightarrow \varphi$, respectively (where φ_i, φ are meta-variables ranging over wff in \mathcal{L}), such that $\mathcal{R}_s \cap \mathcal{R}_d = \emptyset$. Here $\varphi_1, \dots, \varphi_n$ are called the *antecedents* and φ the *consequent* of the rule.²

We write $\psi = -\varphi$ just in case $\psi = \neg\varphi$ or $\varphi = \neg\psi$. Note that $-$ is not part of the logical language \mathcal{L} but a metalinguistic function symbol to obtain more concise definitions. Also, for any rule r the *antecedents* and *consequent* are denoted, respectively, with $\mathbf{ant}(r)$ and $\mathbf{cons}(r)$.

The set \mathcal{R}_s is said to be *closed under transposition* if whenever $S \rightarrow \varphi \in \mathcal{R}_s$, then $S \setminus \{s_i\} \cup -\varphi \rightarrow -s_i \in \mathcal{R}_s$ for any $s_i \in S$. This notion is important since many consistency and closure results in the literature depend on the condition that \mathcal{R}_s is closed under transposition.

Definition 4 (Consistency)

For any $S \subseteq \mathcal{L}$, let the *closure of S under strict rules*, denoted $Cl_{\mathcal{R}_s}(S)$, be the smallest set containing S and the consequent of any strict rule in \mathcal{R}_s whose antecedents are in $Cl_{\mathcal{R}_s}(S)$. Then a set $S \subseteq \mathcal{L}$ is *directly consistent* iff $\nexists \psi, \varphi \in S$ such that $\psi = -\varphi$, and *indirectly consistent* iff $Cl_{\mathcal{R}_s}(S)$ is directly consistent.

Note that the notion of indirect consistency is relative to a given set of strict rules.

² Below the brackets around the antecedents will usually be omitted.

Definition 5 (Knowledge Bases)

A *knowledge base* over an $AS = (\mathcal{L}, \mathcal{R})$ is a set $\mathcal{K} \subseteq \mathcal{L}$.

In this paper, \mathcal{K} corresponds to the “necessary premises” in other ASPIC⁺ publications, which are intuitively certain and therefore not attackable. Since the “facts” in DeLP are also not attackable, we assume in this paper that the set of attackable or “ordinary” premises from other ASPIC⁺ publications is empty. We will, as is also usually done in DeLP, represent what intuitively are uncertain premises φ as defeasible rules $\Rightarrow \varphi$. In what follows, for a given argument, the function **Prem** returns all the formulas of \mathcal{K} (called *premises*) used to build the argument, **Conc** returns its conclusion, **Sub** returns all its subarguments, **LDR** returns the last defeasible rules used in the argument, **Rules** and **DefRules** return, respectively, all rules and all defeasible rules of the argument, and **TopRule** returns the last rule used in the argument. An argument is now formally defined as follows.

Definition 6 (Arguments)

A *argument* A on the basis of a knowledge base \mathcal{K} in an argumentation system AS is a structure obtainable by applying one or more of the following steps finitely many times:

1. φ if $\varphi \in \mathcal{K}$ with: **Prem**(A) = $\{\varphi\}$; **Conc**(A) = φ ; **Sub**(A) = $\{\varphi\}$; **LDR**(A) = \emptyset ; **Rules**(A) = \emptyset ; **DefRules**(A) = \emptyset ; **TopRule**(A) = undefined.
2. $[\{A_1, \dots, A_n\} \rightarrow \psi]^3$ if A_1, \dots, A_n are arguments such that **Conc**(A_1), \dots , **Conc**(A_n) $\rightarrow \psi \in \mathcal{R}_s$ with:
 - Prem**(A) = **Prem**(A_1) $\cup \dots \cup$ **Prem**(A_n);
 - Conc**(A) = ψ ;
 - Sub**(A) = **Sub**(A_1) $\cup \dots \cup$ **Sub**(A_n) $\cup \{A\}$;
 - LDR**(A) = **LDR**(A_1) $\cup \dots \cup$ **LDR**(A_n); **Rules**(A) = **Rules**(A_1) $\cup \dots \cup$ **Rules**(A_n) $\cup \{\text{Conc}(A_1), \dots, \text{Conc}(A_n) \rightarrow \psi\}$;
 - DefRules**(A) = **Rules**(A) $\cap \mathcal{R}_d$;
 - TopRule**(A) = **Conc**(A_1), \dots , **Conc**(A_n) $\rightarrow \psi$.
3. $[\{A_1, \dots, A_n\} \Rightarrow \psi]$ if A_1, \dots, A_n are arguments such that **Conc**(A_1), \dots , **Conc**(A_n) $\Rightarrow \psi \in \mathcal{R}_d$, with:
 - LDR**(A) = $\{\text{Conc}(A_1), \dots, \text{Conc}(A_n) \Rightarrow \psi\}$;
 - Rules**(A) = **Rules**(A_1) $\cup \dots \cup$ **Rules**(A_n) $\cup \{\text{Conc}(A_1), \dots, \text{Conc}(A_n) \Rightarrow \psi\}$;
 - TopRule**(A) = **Conc**(A_1), \dots , **Conc**(A_n) $\Rightarrow \psi$
 and the other notions defined as in (2).

An argument A is *strict* if **DefRules**(A) = \emptyset , otherwise A is *defeasible*.

When **Conc**(A) = φ we sometimes say that A is an argument for φ . Each of the functions **Func** in this definition is also defined on sets of arguments $S = \{A_1, \dots, A_n\}$ as follows: **Func**(S) = **Func**(A_1) $\cup \dots \cup$ **Func**(A_n). Note that we overload the \rightarrow and \Rightarrow symbols to denote an argument while they also denote strict, respectively, defeasible inference rules. This is common practice in argumentation and originates from Vreeswijk (1997).

³ The square brackets make the presentation of examples more concise. They and the curly brackets will be omitted if there is no danger for confusion.

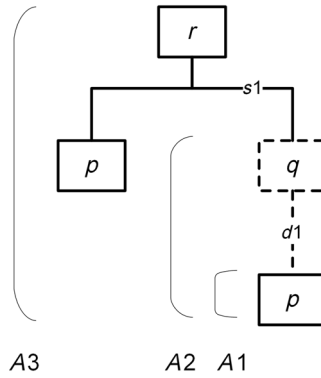

Fig. 1. Argument A_3 from Example 1 with subarguments A_1 and A_2 .

Example 1

Consider a knowledge base in an argumentation system with \mathcal{L} consisting of p, q, r, s, t, u, v, x and their negations, with $\mathcal{R}_s = \{s_1, s_2\}$ and $\mathcal{R}_d = \{d_1, d_2, d_3\}$, where:

$$\begin{array}{ll}
 d_1: & p \Rightarrow q & s_1: & p, q \rightarrow r \\
 d_2: & \Rightarrow t & s_2: & t \rightarrow \neg q \\
 d_3: & v, x \Rightarrow \neg t & s_3: & u \rightarrow v
 \end{array}$$

Let $\mathcal{K} = \{p, u, x\}$. An argument A_3 for r (i.e., with conclusion r) with subarguments A_1 for p and A_2 for q is displayed in Figure 1, with the premises at the bottom and the conclusion at the top of the tree. In this and the next figure, strict inferences are indicated with solid lines while defeasible inferences and rebuttable conclusions are displayed with dotted lines. The figure also displays the formal structure of the argument. Note that the argument can also be written as $[p, [p \Rightarrow q] \rightarrow r]$. We have that

$$\begin{array}{ll}
 \text{Prem}(A_3) = & \{p\} & \text{DefRules}(A_3) = & \{d_1\} \\
 \text{Conc}(A_3) = & r & \text{Rules}(A_3) = & \{s_1, d_1\} \\
 \text{Sub}(A_3) = & \{A_1, A_2, A_3\} & \text{TopRule}(A_3) = & s_1 \\
 \text{LDR}(A_3) = & \{d_1\} & &
 \end{array}$$

All of A_1 , A_2 , and A_3 are defeasible since $\text{DefRules}(A_1) = \text{DefRules}(A_2) = \text{DefRules}(A_3) = \{d_1\}$.

In general, $ASPIC^+$ has three ways of attack: on an argument’s uncertain premises (undermining attack), on the conclusion of a defeasible rule (rebutting attack), and on a defeasible rule itself (undercutting attack). However, in this paper, we only consider rebutting attack.

Definition 7 (Rebutting Attack)

A attacks or rebuts B iff $\text{Conc}(A) = -\varphi$ for some $B' \in \text{Sub}(B)$ of the form $B'_1, \dots, B'_n \Rightarrow \varphi$.

Example 2

In our running example, argument A_3 is rebutted on A_2 by an argument B_2 for $\neg q$:

$$\begin{array}{l}
 B_1: \Rightarrow t \\
 B_2: B_1 \rightarrow \neg q
 \end{array}$$

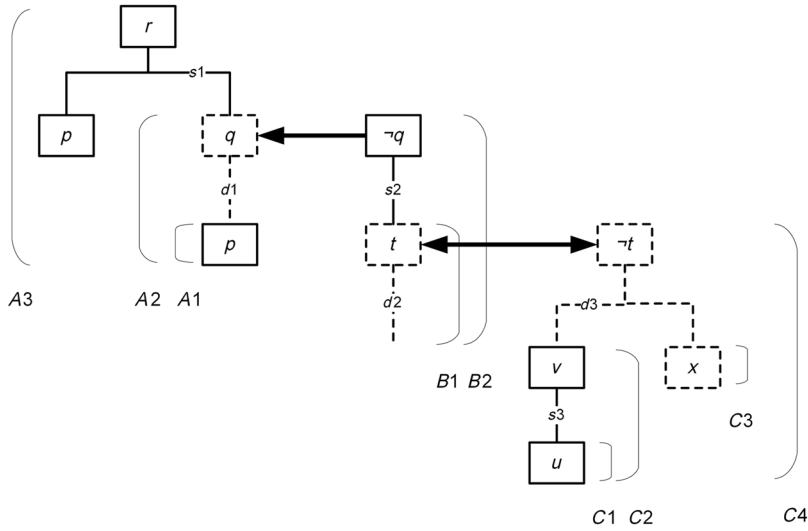

Fig. 2. The arguments and attacks in the running example.

Note that A_2 does not in turn rebut B_2 on B_2 , since B_2 has a strict top rule while the argument on which an argument is (directly) rebutted has to have a defeasible top rule. For the same reason, B_2 can potentially only be rebutted on B_1 . Our argumentation theory allows for such a rebuttal:

- $C_1: u$
- $C_2: C_1 \rightarrow v$
- $C_3: x$
- $C_4: C_2, C_3 \Rightarrow \neg t$

Note that B_1 in turn rebuts C_4 , since C_4 has a defeasible top rule. All arguments and (direct) attacks in the example are displayed in Figure 2.

Caminada and Amgoud (2007) also consider a variant called “unrestricted rebut,” which allows direct rebuttals on arguments with a strict top rule provided the attacked argument is defeasible:

Definition 8 (Unrestricted Rebutting Attack)

A u -rebuts B iff $\text{Conc}(A) = \neg \text{Conc}(B')$ for some defeasible $B' \in \text{Sub}(B)$.

Example 3

In our running example, this yields one additional rebutting relation, since A_2 u -rebuts B_2 . Furthermore, argument A_3 can be potentially u -rebutted on its final conclusion r . However, C_2 cannot be u -rebutted, since it is not defeasible but strict.

Below we will assume Definition 7 of attack unless specified otherwise.

The ASPIC⁺ counterpart of an abstract AF is a structured AF (SAF).

Definition 9 (Structured AFs)

Let AT be an argumentation theory (AS, \mathcal{K}) . A structured argumentation framework (SAF) defined by AT is a triple $\langle \mathcal{A}, \mathcal{C}, \preceq \rangle$, where \mathcal{A} is the set of all arguments on the basis of AS , \preceq is an ordering on \mathcal{A} , and $(X, Y) \in \mathcal{C}$ iff X attacks Y .

Example 4

In our running example $\mathcal{A} = \{A_1, A_2, A_3, B_1, B_2, C_1, C_2, C_3, C_4\}$, while \mathcal{C} is such that B_2 attacks both A_2 and A_3 , argument C_4 attacks both B_1 and B_2 , and B_1 attacks C_4 .

The attack relation tells us which arguments are in conflict with each other. If an argument A *successfully attacks*, that is, *defeats*, B , then A can be used as a counterargument to B . Whether a rebutting attack succeeds as a defeat, depends on the argument ordering \preceq . In the following definition, $A \prec B$ is defined as usual as $A \preceq B$ and $B \not\preceq A$.

Definition 10 (Defeat)

Argument A *defeats* argument B if A rebuts B on B' and $A \not\prec B'$.

Example 5

In our running example, the attack of B_2 on A_2 (and thereby on A_3) succeeds if $B_1 \not\prec A_2$. In that case, B_2 strictly defeats both A_2 and A_3 . If B_1 and C_4 are incomparable or of equal priority, then these two arguments defeat each other, while C_4 strictly defeats B_2 . If $C_4 \prec B_1$, then B_1 strictly defeats C_4 while if $B_1 \prec C_4$, then C_4 strictly defeats both B_1 and B_2 .

AFs are then generated from *SAFs* by letting the attacks from an *AF* be the defeats from a *SAF*.

Definition 11 (AFs corresponding to SAFs)

An *abstract argumentation framework (AF) corresponding to a SAF* $\langle \mathcal{A}, \mathcal{C}, \preceq \rangle$ (where \mathcal{C} is *ASPIC⁺*'s attack relation) is a pair $(\mathcal{A}, \textit{attack})$ such that *attack* is the defeat relation on \mathcal{A} determined by *SAF*.

A nonmonotonic consequence notion can then be defined as follows. Let $T \in \{\textit{complete}, \textit{preferred}, \textit{grounded}, \textit{stable}\}$ and let \mathcal{L} be from the *AT* defining *SAF*. A wff $\varphi \in \mathcal{L}$ is *sceptically T-justified* in *SAF* if φ is the conclusion of a sceptically *T-justified* argument, and *credulously T-justified* in *SAF* if φ is not sceptically *T-justified* and is the conclusion of a credulously *T-justified* argument.

Example 6

In our running example, if B_2 does not defeat A_2 , then all extensions in any semantics contain A_3 so r is sceptically justified. Let us next assume that B_2 defeats A_2 . Then if C_4 strictly defeats B_1 , we have a unique extension in all semantics, namely $\{A_1, A_2, A_3, C_1, C_2, C_3, C_4\}$. In both cases, this yields that wff r is sceptically justified. Alternatively, if B_1 strictly defeats C_4 , then there again is a unique extension in all semantics, which now is $\{A_1, B_1, B_2, C_1, C_2, C_3\}$. Then r is neither sceptically nor credulously justified. Finally, if B_1 and C_4 defeat each other, then the grounded extension is $E = \{A_1, C_1, C_2, C_3, C_4\}$ while there are two preferred extensions $E_1 = \{A_1, A_2, A_3, C_1, C_2, C_3, C_4\}$ and $E_2 = \{A_1, B_2, C_1, C_2, C_3\}$. So then r is credulously but not sceptically justified in preferred semantics but is neither sceptically nor credulously justified in grounded semantics.

3.3 Defeasible Logic Programming

DeLP is a formalization of defeasible reasoning in which results of logic programming and argumentation are combined. *DeLP* has the declarative capability of representing knowledge in a language that extends the language of logic programming with the

possibility of representing weak information in the form of *defeasible rules*, and an argumentation-based inference mechanism for warranting conclusions.

While ASPIC⁺ in general abstracts from the logical language, DeLP chooses a logic-programming language with “strong” negation to represent knowledge in which the antecedents and consequent of a rule (strong or weak) are ground literals. It is possible to employ in DeLP default negation, which is also known as negation as failure, but since this does not crucially change the analysis below, we will for simplicity ignore this extension here. As usual, rules written with free variables are schemes for all their ground instances. Although DeLP and the instance of ASPIC⁺ presented above are similar, they are not fully equivalent. Elements in which DeLP and ASPIC⁺ coincide are the predicate-logic literal language with strong negation, a set of indisputable facts, two sets of strict and defeasible rules, and a binary argument preference relation. However, DeLP’s definitions of argument, attack, and defeat are not equivalent to those of ASPIC⁺. Moreover, a significant difference with ASPIC⁺ is that DeLP, as defined by García and Simari (2004), does not evaluate arguments by generating abstract argumentation frameworks. Instead, DeLP’s notion of *warrant* is defined in terms of dialectical trees in a way that is similar to the argument game of grounded semantics but with some significant differences, as we will see below.

This section will introduce a description of DeLP’s features for knowledge representation [mainly taken from García and Simari (2014)], then the details concerning its inference mechanism will be explained. Although the work leading to the formalization of DeLP began in the early 1990s (Simari *et al.* 1994a,b) as an evolution of the work of Simari and Loui (1992), its formalization was completed by García (2000) and finally published in García and Simari (2004, 2014). Further developments can be found in the following related material: (García *et al.* 2007, 2013; Tucat *et al.* 2009; Martínez *et al.* 2012; Cohen *et al.* 2016; García and Simari 2018).

The knowledge representation language of DeLP is determined by a set of *atoms*. Atoms can be preceded by the *strong negation* symbol “ \sim ”. Atoms that are not preceded by strong negation will also be called *positive literals* and atoms preceded by strong negation will be called *negative literals*, the term *literal*, or sometimes *objective literal*, will refer to either one. A pair of literals involving a positive and a negative literal over the same atom are called *complementary* or *contradictory*. For instance, “ \sim guilty” and “guilty” are two complementary literals. A *defeasible logic program*, abbreviated *dlp*, is a set of facts, strict rules, and defeasible rules defined as follows:

- *Facts* are ground (objective) literals, for example, *guilty*, *price(100)*, \sim *close*. In DeLP, facts are used for representing information that is considered to hold in the application domain. Hence, as it will be explained below, a *dlp* cannot contain two complementary facts.
- *Strict Rules* represent a relation between a ground literal L_0 , or *head* of the rule, and a set of ground literals $\{L_i\}_{i>0}$, or *body* of the rule, and are denoted $L_0 \leftarrow L_1, \dots, L_n$; strict rules correspond syntactically to *basic rules* in logic programming (Lifschitz 1996). The use of the adjective “strict” emphasizes that the relation between the head and the body of the rule is such that if the body is accepted then the head must also be accepted. The examples of strict rules shown below can be understood as expressing that: *someone who is guilty cannot be innocent*, *cats are mammals*, and *if there are not many surfers then there are few surfers*:

$$\begin{aligned} \sim\text{innocent} &\leftarrow \text{guilty} \\ \text{mammal} &\leftarrow \text{cat} \\ \text{few_surfers} &\leftarrow \sim\text{many_surfers} \end{aligned}$$

- *Defeasible Rules* are used to represent a weaker connection between pieces of information, they are denoted $L_0 \multimap L_1, \dots, L_n$, and like strict rules, the head of the rule L_0 is a ground literal and its body $\{L_i\}_{i \geq 0}$ is a set of ground literals. A defeasible rule with empty body is called a *presumption*; sometimes we will also call the head of such a rule a presumption. Note that initially [García and Simari \(2004\)](#) required defeasible rules to have nonempty bodies. Here and below, we follow their extension in Section 6.2 of *DeLP* with presumptions. Unlike strict rules, acceptance of the body of a defeasible rule does not always lead to the acceptance of the head. Examples of defeasible rules follow. The first one represents that *usually, mosquitoes are not dangerous*, and the second says that *reasons to believe mosquitoes are carrying dengue, justify the belief they are dangerous*:

$$\begin{aligned} \sim\text{dangerous} &\multimap \text{mosquito} \\ \text{dangerous} &\multimap \text{mosquito, dengue} \end{aligned}$$

Note that, from a syntactic point of view, strict and defeasible rules differ only in the symbol between the head and the body of the rule. It is interesting to remark here that the representational choice between these two forms of relating the head and the body of a rule is ultimately a matter of context, sometimes a rule could change accordingly to the environment in which it is used; for instance, a rule that locally can be considered strict could become defeasible in a larger environment. Defeasible rules allow to represent a weak connection between the body (antecedent) and the head (consequence) of the rule. A defeasible rule $H \multimap B$ expresses that reasons to believe in B provide a (defeasible) reason to believe in H . As an example, consider a scenario where an agent has to decide how to spend the day. Then, the defeasible rule “*nice \multimap waves*” can represent that “*reasons to believe that there are big waves at the beach, is a reason to believe that it should be a nice day for surfing.*” The connection between “*waves*” and “*nice*” is weak in the sense that there might be other reasons such as “*normally, if it is raining it is not nice for surfing,*” represented as “ *\sim nice \multimap rain,*” that will lead to the contrary conclusion. Suppose that today there are big waves and it is raining, then the acceptance of the body of the rule “*nice \multimap waves*” does not lead directly to the acceptance of the head.

Nevertheless, strict rules establish a strict connection between body and head; thus, the rule “ *\sim working \leftarrow vacation*” represents the fact that in vacation an agent is not working. Then, as we will show below, due to this strict connection in *DeLP* if “*vacation*” is accepted, then “ *\sim working*” is also accepted.

Note that the symbols “ \multimap ” and “ \leftarrow ” denote meta-relations between a literal and a set of literals, and have no interaction with language symbols. As in logic programming, strict and defeasible rules are not conditionals nor implications, they are inference rules. Consequently, strict rules do not automatically contrapose or (in [Caminada and Amgoud's 2007](#) terms) “transpose.” In *DeLP*, a knowledge engineer has to separately determine for each strict rule whether adding its transposition is appropriate for that rule. This is relevant since many positive results in the literature on satisfaction of [Caminada and Amgoud's](#) rationality postulates depend on the assumption that the set of strict rules is closed under transposition.

Definition 12 (Defeasible Logic Program)

A defeasible logic program (*dlp*) is set of facts, rules, and presumptions. However, when required, a *dlp* is denoted (Π, Δ) , to distinguish the subset Π of facts and strict rules and the subset Δ of defeasible rules and presumptions. Moreover, when we want to refer to just the facts in Π we write Π_f and for the strict rules we write Π_s . Naturally, $\Pi_f \cup \Pi_s = \Pi$.

Example 7

$$\Pi_7 = \left\{ \begin{array}{l} \textit{monday} \\ \textit{cloudy} \\ \textit{dry_season} \\ \textit{waves} \\ \textit{grass_grown} \\ \textit{hire_gardener} \\ \textit{vacation} \\ \sim\textit{working} \leftarrow \textit{vacation} \\ \textit{few_surfers} \leftarrow \sim\textit{many_surfers} \\ \sim\textit{surf} \leftarrow \textit{ill} \end{array} \right\} \quad \Delta_7 = \left\{ \begin{array}{l} \textit{surf} \prec \textit{nice}, \textit{spare_time} \\ \textit{nice} \prec \textit{waves} \\ \sim\textit{nice} \prec \textit{rain} \\ \textit{rain} \prec \textit{cloudy} \\ \sim\textit{rain} \prec \textit{dry_season} \\ \textit{spare_time} \prec \sim\textit{busy} \\ \sim\textit{busy} \prec \sim\textit{working} \\ \textit{cold} \prec \textit{winter} \\ \textit{working} \prec \textit{monday} \\ \textit{busy} \prec \textit{yard_work} \\ \textit{yard_work} \prec \textit{grass_grown} \\ \sim\textit{yard_work} \prec \textit{hire_gardener} \\ \textit{many_surfers} \prec \textit{waves} \\ \sim\textit{many_surfers} \prec \textit{monday} \end{array} \right\}$$

Definition 13 (Defeasible Derivation)

Given a *dlp* (Π, Δ) , a *defeasible derivation* of a ground literal L from (Π, Δ) , denoted as $(\Pi, \Delta) \vdash \sim L$, is a finite sequence $L_1, \dots, L_n = L$ of ground literals such that for all $L_i (1 \leq i \leq n)$: $L_i \in \Pi$ or L_i is a presumption in Δ ; or there exists a rule R_i in (Π, Δ) (strict or defeasible) with head L_i and body B_1, B_2, \dots, B_m such that every literal $B_j, 1 \leq j \leq m$, of the body is an element L_k already appearing in the sequence preceding $L_i (k < i)$. If L has a derivation that only uses facts and strict rules from Π and no defeasible rules, in this case we say that L has a *strict derivation*.

In the program (Π_7, Δ_7) shown in Example 7, the literal *surf* has a defeasible derivation: *vacation, ~working, ~busy, spare_time, waves, nice, surf*, which contains two facts (*vacation* and *waves*), and the use of a strict rule ($\sim\textit{working} \leftarrow \textit{vacation}$) and four defeasible rules. Note that every fact of a *DeLP* has a defeasible derivation; however, not every head of a rule has a derivation, for instance, neither *cold* nor $\sim\textit{surf}$ have a defeasible derivation. Note that $\sim\textit{working}$ has a strict derivation from Π_7 . Note that literals that have a strict derivation must be facts or the head of a strict rules; however, a literal can be the head of a strict rule and might have a defeasible derivation, but not a strict derivation. For instance, *few_surfers* has no strict derivation from Π_7 , although it has a defeasible derivation from (Π_7, Δ_7) that uses a defeasible rule for the derivation of $\sim\textit{many_surfers}$.

It is important to note that in *DeLP* the set Π is used to represent non-defeasible information, consequently it is required that the set be representationally coherent. Therefore, for any program (Π, Δ) , we assume that Π is non-contradictory: no pair of contradictory literals can be derived from Π , that is, no strict derivation for complementary literals can be obtained from a *DeLP*. Saying that Π is non-contradictory is equivalent to saying in *ASPIC⁺* that \mathcal{K} is indirectly consistent relative to \mathcal{R}_s .

Definition 14 (Argument)

Let (Π, Δ) be a *dlp* and L a ground literal. We say that \mathcal{A} is an **argument** for the conclusion L from (Π, Δ) , denoted $\langle \mathcal{A}, L \rangle$, if \mathcal{A} is a set of defeasible rules ($\mathcal{A} \subseteq \Delta$), such that:

1. there exists a defeasible derivation for L from $\Pi \cup \mathcal{A}$, and
2. no pair of contradictory literals can be defeasibly derived from $\Pi \cup \mathcal{A}$.
3. \mathcal{A} is minimal in that there is no proper subset of \mathcal{A} satisfying conditions (1) and (2).

Observe that although facts and strict rules are used in the defeasible derivation, the argument structure only mentions the defeasible rules, that is, facts and strict rules are not part of an argument. Note also that unlike in Definition 6 of *ASPIC*⁺-arguments, the set of defeasible rules of a *DeLP* argument has to be minimal and its set of “conclusions” has to be indirectly consistent. (Strictly speaking, the set of conclusions of a *DeLP* argument is not formally defined, but the set of all literals in the defeasible derivation corresponding to an argument can be seen as such.)

Note that it could happen that a literal L has a defeasible derivation from a *dlp* but there is no argument for L from that *dlp*. For instance, consider the *dlp* (Π_7, Δ_7) of Example 7, from the fact *monday* and the defeasible rule *working* \multimap *monday*, there is a defeasible derivation for the literal *working*. However, note that there is a strict derivation for \sim *working*, and hence from the set $\Pi_7 \cup \{\textit{working} \multimap \textit{monday}\}$ both literals *working* and \sim *working* can be defeasibly derived, for that reason there is no argument for the literal *working* from (Π_7, Δ_7) . Consider $S = \{\textit{nice} \multimap \textit{waves}, \sim \textit{busy} \multimap \sim \textit{working}\} \subseteq \Delta_7$. Observe that $S \cup \Pi_7$ is non-contradictory and allows for the defeasible derivation of *nice*; however, S is not an argument for *nice* because it is not minimal. Observe that $\mathcal{A}_2 \subset S$ is an argument for *nice*: $\mathcal{A}_2 = \{\textit{nice} \multimap \textit{waves}\}$.

Attack on arguments is in *DeLP* defined in terms of disagreement between literals. Two literals L and Q are said to disagree in the context of the program (Π, Δ) if the set $\Pi \cup \{L, Q\}$ is contradictory, that is, from $\Pi \cup \{L, Q\}$ is possible to strictly derive a literal and its complementary. For example, given $\Pi = \{(h \leftarrow a), (\sim h \leftarrow b)\}$, the literals a and b disagree. This notion of disagreement allows us to find direct and indirect conflicts between arguments. This is equivalent to saying in *ASPIC*⁺ that $\mathcal{K} \cup \{L, Q\}$ is indirectly inconsistent relative to \mathcal{R}_s . Note that two complementary literals always disagree (e.g., *nice* and \sim *nice*). Since for any program (Π, Δ) it is required that Π be non-contradictory, the disagreement cannot come from Π .

Given a *dlp* (Π, Δ) and two arguments $\langle \mathcal{A}, L \rangle$ and $\langle \mathcal{B}, Q \rangle$ obtained from it, if $\mathcal{B} \subseteq \mathcal{A}$, then we say that $\langle \mathcal{B}, Q \rangle$ is a *subargument* of $\langle \mathcal{A}, L \rangle$ and that $\langle \mathcal{A}, L \rangle$ is the *superargument* of $\langle \mathcal{B}, Q \rangle$ (note that trivially every argument is a subargument/superargument of itself).

Definition 15 (Counterargument/Attack)

In *DeLP*, an argument $\langle \mathcal{B}, Q \rangle$ is a *counterargument* for $\langle \mathcal{A}, L \rangle$ at literal P , if there exists a subargument $\langle \mathcal{C}, P \rangle$ of $\langle \mathcal{A}, L \rangle$ such that P and Q disagree. The literal P is referred to as the *counterargument point* and $\langle \mathcal{C}, P \rangle$ as the *disagreement subargument*. If $\langle \mathcal{B}, Q \rangle$ is a counterargument for $\langle \mathcal{A}, L \rangle$, then we also say that $\langle \mathcal{B}, Q \rangle$ *attacks* $\langle \mathcal{A}, L \rangle$, and that $\langle \mathcal{B}, Q \rangle$ and $\langle \mathcal{A}, L \rangle$ are in *conflict*.

Except for the disagreement check instead of a simple syntactic check for complementarity, this definition is similar to Definition 7 of rebutting attack in *ASPIC*⁺ in that an argument can attack a subargument of its target and does so on a specific point. On the

other hand, unlike in ASPIC⁺, in DeLP the attacking point can be the consequent of a strict rule. For instance, we include below Example 4 “Married John” from Caminada and Amgoud (2007) in terms of DeLP syntax.

Example 8

Let $\Pi_8 = \{wr, go, \sim hw \leftarrow b, hw \leftarrow m, \}$ and $\Delta_8 = \{m \multimap wr, b \multimap go\}$ with: $wr =$ “John wears something that looks like a wedding ring,” $go =$ “John often goes out until late with his friends,” $hw =$ “John has a wife,” $b =$ “John is a bachelor,” $m =$ “John is married.” The following arguments can be constructed:

$$\begin{array}{ll} \mathcal{A}_1: & \langle \{ \}, wr \rangle & \mathcal{A}_2: & \langle \{ \}, go \rangle \\ \mathcal{A}_3: & \langle \{m \multimap wr\}, m \rangle & \mathcal{A}_4: & \langle \{b \multimap go\}, b \rangle \\ \mathcal{A}_5: & \langle \{m \multimap wr\}, hw \rangle & \mathcal{A}_6: & \langle \{b \multimap go\}, \sim hw \rangle \end{array}$$

In DeLP arguments, \mathcal{A}_1 and \mathcal{A}_2 have no defeaters; argument \mathcal{A}_5 defeats \mathcal{A}_6 and vice versa; and argument \mathcal{A}_3 defeats \mathcal{A}_4 and vice versa. Note also that argument \mathcal{A}_3 defeats \mathcal{A}_6 and argument \mathcal{A}_4 defeats \mathcal{A}_5 . Consequently, $b =$ “John is a bachelor” and $m =$ “John is married” are not warranted (justified).

As a further example, consider the dlp (Π_7, Δ_7) of Example 7 and the sets $\mathcal{A}_1 = \{(\sim nice \multimap rain) ; (rain \multimap cloudy)\}$, $\mathcal{A}_2 = \{nice \multimap waves\}$, $\mathcal{A}_3 = \{rain \multimap cloudy\}$, $\mathcal{A}_4 = \{\sim rain \multimap dry_season\}$. Then, $\langle \mathcal{A}_1, \sim nice \rangle$ is a counterargument for $\langle \mathcal{A}_2, nice \rangle$ and vice versa because in this particular case the conclusion of both arguments disagrees. As another example, $\langle \mathcal{A}_4, \sim rain \rangle$ is a counterargument for $\langle \mathcal{A}_1, \sim nice \rangle$ at the counterargument point $rain$ and $\langle \mathcal{A}_3, rain \rangle$ is the disagreement subargument. Note that in DeLP, a counterargument for an argument \mathcal{A} is also a counterargument for any superargument of \mathcal{A} . Also note that in DeLP there is no possible counterargument for a claim having a strict derivation, see García and Simari (2004) for the proof. Observe that from (Π_7, Δ_7) there is a strict derivation for $\sim working$, however, although there is a derivation for $working$, no argument for $working$ can exist, and hence, no counterargument for $\sim working$.

The argument comparison criterion is modular in DeLP; hence, it is possible to use any preference criterion established over the set of arguments (see García and Simari 2014 for details and Teze et al. 2015 for an application). This allows the user to select the most appropriate criterion for the application domain that is being represented. For the rest of the presentation, we will assume an abstract preference criterion \prec of strict comparison on the set of arguments, where $A \prec B$ means that argument B is strictly better than argument A .

Definition 16 (Defeaters)

Argument $\langle \mathcal{A}_1, L_1 \rangle$ is a *proper defeater* of argument $\langle \mathcal{A}_2, L_2 \rangle$ iff there exists a subargument $\langle \mathcal{A}, L \rangle$ of $\langle \mathcal{A}_2, L_2 \rangle$ such that $\langle \mathcal{A}_1, L_1 \rangle$ attacks $\langle \mathcal{A}, L \rangle$ at literal L and $\langle \mathcal{A}, L \rangle \prec \langle \mathcal{A}_1, L_1 \rangle$. Argument $\langle \mathcal{A}_1, L_1 \rangle$ is a *blocking defeater* of argument $\langle \mathcal{A}_2, L_2 \rangle$ iff there exists a subargument $\langle \mathcal{A}, L \rangle$ of $\langle \mathcal{A}_2, L_2 \rangle$ such that $\langle \mathcal{A}_1, L_1 \rangle$ attacks $\langle \mathcal{A}, L \rangle$ at literal L and $\langle \mathcal{A}, L \rangle \not\prec \langle \mathcal{A}_1, L_1 \rangle$ and $\langle \mathcal{A}_1, L_1 \rangle \not\prec \langle \mathcal{A}, L \rangle$. Argument A is a *defeater* of argument B iff A is a proper or a blocking defeater of B .

In the context of program (Π_7, Δ_7) , $\langle \mathcal{A}_4, \sim rain \rangle$ is a counterargument for $\langle \mathcal{A}_1, \sim nice \rangle$ at the counterargument point $rain$ and $\langle \mathcal{A}_3, rain \rangle$ is the disagreement subargument; therefore, \mathcal{A}_4 is compared with \mathcal{A}_3 to determine if it is a defeater.

To facilitate comparison of both approaches, in the rest of the paper, a *DeLP* strict rule $a \leftarrow b$ can also be denoted using *ASPIC*⁺ notation as $b \rightarrow a$, and defeasible rule $a \prec b$ as $b \Rightarrow a$. Also, a *dlp* (Π, Δ) can be denoted $(\mathcal{K}, \mathcal{R}_s, \mathcal{R}_d)$ assuming $\Pi = \mathcal{K} \cup \mathcal{R}_s$ and $\Delta = \mathcal{R}_d$.

The notions of proper and blocking defeater are not equivalent to the *ASPIC*⁺ notions of strict and weak defeater (see Section 3.1). Consider the following example:

Example 9

Consider a *dlp* with $\mathcal{K} = \{q, s\}$, $\mathcal{R}_s = \emptyset$ and $\mathcal{R}_d = \{p \prec; r \prec p, q; \neg r \prec; \neg p \prec \neg r, s\}$. Then we have the following *DeLP* arguments:

$$\begin{array}{ll} \mathcal{A}_1: & \langle \{p \prec\}, p \rangle & \mathcal{A}_2: & \langle \{p \prec; r \prec p, q\}, r \rangle \\ \mathcal{B}_1: & \langle \{\neg r \prec\}, \neg r \rangle & \mathcal{B}_2: & \langle \{\neg r \prec; \neg p \prec \neg r, s\}, \neg p \rangle \end{array}$$

And let $\mathcal{A}_1 \prec \mathcal{B}_2$ and $\mathcal{B}_1 \prec \mathcal{A}_2$ (a preference based on strict specificity). Note that \mathcal{A}_1 is a subargument of \mathcal{A}_2 and \mathcal{B}_1 is a subargument of \mathcal{B}_2 . Then, \mathcal{A}_2 and \mathcal{B}_2 are proper defeaters of each other, while the *ASPIC*⁺ relation of strict defeat is asymmetric. Note also that \mathcal{A}_2 and \mathcal{B}_2 weakly defeat each other while they are not blocking defeaters of each other.

An *argumentation line* for an argument $\langle \mathcal{A}_1, L_1 \rangle$ is a sequence of arguments from a *dlp*, denoted $\Lambda = [\langle \mathcal{A}_1, L_1 \rangle, \langle \mathcal{A}_2, L_2 \rangle, \langle \mathcal{A}_3, L_3 \rangle, \dots]$, where each element of the sequence $\langle \mathcal{A}_i, L_i \rangle$, $i > 1$, is a defeater of its predecessor $\langle \mathcal{A}_{i-1}, L_{i-1} \rangle$. The first element, $\langle \mathcal{A}_1, L_1 \rangle$, becomes a *supporting* argument for the conclusion L_1 , $\langle \mathcal{A}_2, L_2 \rangle$ an *interfering* argument, $\langle \mathcal{A}_3, L_3 \rangle$ a supporting argument, $\langle \mathcal{A}_4, L_4 \rangle$ an interfering one, continuing in that manner. Thus, an argumentation line can be split into two disjoint sets: $\Lambda_S = \{\langle \mathcal{A}_1, L_1 \rangle, \langle \mathcal{A}_3, L_3 \rangle, \langle \mathcal{A}_5, L_5 \rangle, \dots\}$ of supporting arguments for the conclusion L_1 , and $\Lambda_I = \{\langle \mathcal{A}_2, L_2 \rangle, \langle \mathcal{A}_4, L_4 \rangle, \dots\}$ of interfering arguments for L_1 .

Definition 17

Given a program (Π, Δ) , a set of arguments $\{\langle \mathcal{A}_i, L_i \rangle\}_{i=1}^k$ is concordant if it is not possible to have a defeasible derivation for a pair of contradictory literals from the set $\Pi \cup \bigcup_{i=1}^k \mathcal{A}_i$.

*Definition 18 (Acceptable Argumentation Line)*⁴

An argumentation line $\Lambda = [\langle \mathcal{A}_1, L_1 \rangle, \dots, \langle \mathcal{A}_n, L_n \rangle]$ from a *dlp* (Π, Δ) is *acceptable* if and only if:

1. Λ is a finite sequence.
2. The set Λ_S of supporting arguments (resp. Λ_I) is concordant.
3. No argument $\langle \mathcal{A}_k, L_k \rangle$ in Λ is a subargument of an argument $\langle \mathcal{A}_i, L_i \rangle$ appearing earlier in Λ , $i < k$.
4. For all i , such that $\langle \mathcal{A}_i, L_i \rangle$ is a blocking defeater for $\langle \mathcal{A}_{i-1}, L_{i-1} \rangle$, if $\langle \mathcal{A}_{i+1}, L_{i+1} \rangle$ exists, then $\langle \mathcal{A}_{i+1}, L_{i+1} \rangle$ is a proper defeater for $\langle \mathcal{A}_i, L_i \rangle$.

Given a program, there can be more than one argumentation line starting with the same argument $\langle \mathcal{A}, L \rangle$. Therefore, analyzing a single acceptable argumentation line for

⁴ García and Simari 2004's definition of acceptable argumentation line has been modified in a 2014 work (García and Simari 2014) and recently in an unpublished paper correcting some unsuitable behavior in particular cases pointed out by Henry Prakken (see Example 15).

$\langle \mathcal{A}, L \rangle$ will not be enough to determine whether $\langle \mathcal{A}, L \rangle$ is an undefeated argument. In the general situation, there might be several defeaters $\langle \mathcal{B}_1, Q_1 \rangle, \langle \mathcal{B}_2, Q_2 \rangle, \dots, \langle \mathcal{B}_k, Q_k \rangle$ for $\langle \mathcal{A}_1, L_1 \rangle$, and for each defeater $\langle \mathcal{B}_i, Q_i \rangle$ there could be in turn several defeaters; thus, a tree structure is defined which is called a dialectical tree. In this tree, the root is labeled with $\langle \mathcal{A}, L \rangle$ and every node (except the root) represents a defeater (proper or blocking) of its parent. Each branch in the tree, that is, each path from a leaf to the root, corresponds to a different acceptable argumentation line.

Definition 19 (Dialectical Trees)

Let $\langle \mathcal{A}_1, L_1 \rangle$ be an argument obtained from a DeLP-program \mathcal{P} , a dialectical tree for $\langle \mathcal{A}_1, L_1 \rangle$ from \mathcal{P} is denoted $\mathcal{T}_{\langle \mathcal{A}_1, L_1 \rangle}$ and is constructed as follows:

1. The root of the tree is labeled with $\langle \mathcal{A}_1, L_1 \rangle$.
2. Let N be a node labeled $\langle \mathcal{A}_n, L_n \rangle$, and $[\langle \mathcal{A}_1, L_1 \rangle, \dots, \langle \mathcal{A}_n, L_n \rangle]$ be the sequence of labels of the path from the root to N . Let $\{\langle \mathcal{B}_1, Q_1 \rangle, \langle \mathcal{B}_2, Q_2 \rangle, \dots, \langle \mathcal{B}_k, Q_k \rangle\}$ be the set of all the defeaters for $\langle \mathcal{A}_n, L_n \rangle$ from \mathcal{P} . For each defeater $\langle \mathcal{B}_i, Q_i \rangle$ ($1 \leq i \leq k$), such that the argumentation line $\Lambda' = [\langle \mathcal{A}_1, L_1 \rangle, \dots, \langle \mathcal{A}_n, L_n \rangle, \langle \mathcal{B}_i, Q_i \rangle]$ is acceptable, the node N has a child N_i labeled $\langle \mathcal{B}_i, Q_i \rangle$. If there is no defeater for $\langle \mathcal{A}_n, L_n \rangle$ or there is no $\langle \mathcal{B}_i, Q_i \rangle$ such that Λ' is acceptable, then N is a leaf.

A dialectical tree provides a useful structure for considering all possible acceptable argumentation lines that can be generated for deciding whether the starting argument is defeated. Given a literal L and an argument $\langle \mathcal{A}, L \rangle$, to decide whether the literal L is warranted, every node in the dialectical tree $\mathcal{T}_{\langle \mathcal{A}, L \rangle}$ is recursively marked as “D” (defeated) or “U” (undefeated), obtaining a marked dialectical tree $\mathcal{T}_{\langle \mathcal{A}, L \rangle}^*$. Nodes are marked by a bottom-up procedure that starts marking all leaves in $\mathcal{T}_{\langle \mathcal{A}, L \rangle}^*$ as “U”. Then, for each inner node $\langle \mathcal{B}, Q \rangle$ of $\mathcal{T}_{\langle \mathcal{A}, L \rangle}^*$, either:

- (a) $\langle \mathcal{B}, Q \rangle$ will be marked as “U” iff every child of $\langle \mathcal{B}, Q \rangle$ is marked as “D”, or
- (b) $\langle \mathcal{B}, Q \rangle$ will be marked as “D” iff it has at least a child marked as “U”.

This marking procedure provides an effective way of determining if a DeLP-query L is warranted. It is important to note that given a DeLP-query L , there can be several arguments that support L ; therefore, L will be warranted if there exists at least one argument \mathcal{A} for L such that the root of a dialectical tree for $\langle \mathcal{A}, L \rangle$ is marked as “U”. Given an argument $\langle \mathcal{A}, L \rangle$ obtained from a program \mathcal{P} , we will write $Mark(\mathcal{T}_{\langle \mathcal{A}, L \rangle}^*) = U$ to denote that the root of $\mathcal{T}_{\langle \mathcal{A}, L \rangle}^*$ is marked as “U”; otherwise, we will write $Mark(\mathcal{T}_{\langle \mathcal{A}, L \rangle}^*) = D$ (if the root of $\mathcal{T}_{\langle \mathcal{A}, L \rangle}^*$ is marked as “D”). Thus, we can define warrant in terms of the marking procedure *Mark*:

Definition 20 (Warrant)

Let (Π, Δ) be a dlp and L a ground literal. We say that L is warranted from (Π, Δ) if there exists at least one argument $\langle \mathcal{A}, L \rangle$ from (Π, Δ) , such that $Mark(\mathcal{T}_{\langle \mathcal{A}, L \rangle}^*) = U$, we also say that $\mathcal{T}_{\langle \mathcal{A}, L \rangle}^*$ warrants L and that \mathcal{A} is a warrant for L . When no such argument exists the literal L is said to be unwarranted.

Each acceptable argumentation line can be seen as a two-player argument game like the grounded game except that the rules of the game are given by the conditions of Definition 18 on acceptable argument lines. Thus, there is an equivalence between the above definition of warrant and the notion of a winning strategy for the proponent in

the corresponding argument game. Given a dialectical tree in which the root is labeled U , the proponent in the game has a winning strategy for each defeater moved by the opponent picking a reply from the tree that is labeled U . Conversely, if the proponent has a winning strategy in a game for argument \mathcal{A} , then \mathcal{A} will clearly have to be labeled U in its dialectical tree, since this tree contains the winning strategy as a subtree that contains all legal defeaters of any supporting argument in the tree. This equivalence will be exploited below in Section 6.4 in the proposal to consider a version of *DeLP* where the conclusions will be obtained through grounded semantics, we distinguish this particular system by denoting it as *DeLP*^(GR).

4 Comparing the Argument Definitions

In this section, we compare the argument definitions of *DeLP* and *ASPIC*⁺. At first sight, the deduction nature of *DeLP* arguments would seem to allow a straightforward many-to-one mapping onto *ASPIC*⁺ arguments in that *DeLP* arguments would capture one possible ordering of the inferences in an *ASPIC*⁺ argument. A mapping of this kind was by Prakken (2010) established between the arguments of assumption-based argumentation and *ASPIC*⁺ arguments. However, two features of *DeLP* arguments prevent a straightforward mapping onto *ASPIC*⁺ arguments: the minimality requirement and the consistency requirement. We discuss both requirements in turn.

4.1 On rationality postulates

In this and the following sections, we will report several positive and negative results on satisfaction of the rationality postulates of Caminada and Amgoud (2007). We now make some introductory remarks on these postulates, in order to put the later results into perspective. While it is hard to disagree that the postulates of direct consistency and closure under subarguments should be satisfied, this is different for indirect consistency and closure under strict rules.⁵ Various positions can be adopted. One position (which is the one of Caminada and Amgoud) is that strict closure and indirect consistency should always be satisfied, given the intuitive reading of strict rules S strictly implies p as “If S then always, or without exception, p ”.

Another position (which is the one of the first and third author of this paper) is that these properties are only desirable for sets of arguments that are not attackable (for instance, in *DeLP* or *ASPIC*⁺ sets of arguments that only use facts and strict rules). By contrast, if an antecedent of a strict rule is provided by a defeasible rule, then it may be reasonable to not accept the consequent of the strict rule even if all its antecedents are accepted. This is one reason why a knowledge engineer in *DeLP* has to determine separately for each strict rule whether it transposes (cf. Section 3.3 above).

A third position [adopted by the second author of this paper in Prakken (2016)] is that what is decisive is the properties of the argument ordering. Prakken (2010) defined when an argument is “reasonable” (in a technical sense) and showed that (together with indirect consistency of the necessary part of the knowledge base and closure of the strict rules under contraposition or transposition) both strict closure and indirect consistency

⁵ See similar discussions in formal epistemology on whether justified beliefs should be classically consistent and closed under deduction (Nelkin 2000).

are satisfied for $ASPIC^+$ if the argument ordering is “reasonable.” Modgil and Prakken (2013) showed the same for a weaker definition of reasonable argument orderings. Prakken (2016) agrees with the second position that strict closure should only hold in general for sets of arguments that are not attackable. He then argues that whether strict closure and indirect consistency should hold for other cases depends on whether it makes sense to require that the argument ordering is “reasonable,” and, so he argues, this depends on the nature of the knowledge and inference rules.

With this in mind, in the remainder of this paper, several results on (non-)satisfaction of strict closure and indirect consistency will be reported in a neutral way, without taking a stance on whether these results are good or bad for the investigated system(s). This posture is to leave the door open for more research on this crucial topic.

4.2 Minimality

DeLP requires arguments to be subset-minimal in their sets of defeasible rules. The general $ASPIC^+$ framework imposes no explicit minimality conditions on arguments, although the definition of an $ASPIC^+$ argument is such that it cannot contain “unused” premises or rules: if an argument A contains inferences, then all premises in $\text{Prem}(A)$ and all rules in $\text{Rules}(A)$ are used in at least one inference. In various publications, the addition of minimality conditions on arguments has been studied. Modgil and Prakken (2013) study a minimality requirement on the set of premises in order to establish relations with classical argumentation as studied by Gorgiannis and Hunter (2011). *DeLP* does not impose minimality of premise sets (which in *DeLP* are the facts used in an argument). It can even be the case that a *DeLP* argument which is minimal in its set of defeasible rules is non-minimal in its sets of premises or strict rules. Consider:

$$\begin{aligned} A: & \langle \{f_1 \Rightarrow p; p, f_2 \rightarrow q\}, q \rangle \\ B: & \langle \{f_1 \Rightarrow p; f_1 \Rightarrow r; p, r \Rightarrow q\}, q \rangle \end{aligned}$$

where $\mathcal{K} = \{f_1, f_2\}$. Argument A is minimal in its set of defeasible rules but B is minimal in its sets of premises and strict rules. The $ASPIC^+$ definition of an argument allows arguments that are non-minimal in their set of defeasible rules. The just-given example illustrates this, since $ASPIC^+$ counterparts of both A and B can be constructed.

Requiring arguments to be minimal in their set of defeasible rules makes sense on the assumption that arguments with a non-minimal set of defeasible rules can never be stronger than a minimal version with the same conclusion (this assumption does not hold in general for $ASPIC^+$). For *DeLP*, this assumption is reasonable, since defeasible rules are the only fallible elements in a *DeLP* argument. Given this assumption, the above example shows that if arguments are required to be minimal in their set of defeasible rules, they cannot be required to be also minimal in their sets of premises and/or strict rules.

4.3 Consistency

DeLP arguments have to be consistent in that no pair of complementary literals should be derivable from the set of all facts and strict rules of the program plus the defeasible rules used in the argument. In $ASPIC^+$, this would amount to saying that the set $\text{Conc}(\text{Sub}(A)) \cup \mathcal{K}$ is indirectly consistent (since as noted above, all rules of an $ASPIC^+$

argument are used to derive conclusions). Only one publication on $ASPIC^+$ has studied the same constraint, namely Prakken (2016). However, in that paper, the constraint was combined with a different notion of rebutting attack, in order to capture forms of probabilistic reasoning. Wu and Podlaskewski (2015) study a slightly weaker constraint, namely that $Sub(A)$ is indirectly consistent.

The $DeLP$ consistency constraint is intuitively appealing. However, Wu and Podlaskewski (2015) remark that their slightly weaker constraint for $ASPIC^+$ arguments induces counterexamples to indirect consistency. A very similar example can be constructed in $DeLP$.

Example 10

Consider a dlp with $\Pi_f = \{f_1, f_2\}$, $\Pi_s = \{r \leftarrow p, q; \neg q \leftarrow p, \neg r\}$ and $\Delta = \{p \multimap f_1; \neg r \multimap f_2; q \multimap p\}$. This enables the following $DeLP$ arguments:

- $A_1: \langle \{p \multimap f_1\}, p \rangle$
- $A_2: \langle \{p \multimap f_1; q \multimap p\}, q \rangle$
- $A_3: \langle \{p \multimap f_1; q \multimap p; r \leftarrow p, q\}, r \rangle$
- $A_4: \langle \{\neg r \multimap f_2\}, \neg r \rangle$
- $A_5: \langle \{\neg r \multimap f_2; p \multimap f_1; \neg q \leftarrow p, \neg r\}, \neg q \rangle$

In $DeLP$, both A_2 and A_5 and A_3 and A_4 attack each other. If these conflicts are resolved with a last-link ordering on arguments as defined by Modgil and Prakken (2013), then the following sets of rules have to be compared:

$$\begin{aligned} LDR(A_2) &= \{p \Rightarrow q\} \text{ with } LDR(A_5) = \{f_1 \Rightarrow p; f_2 \Rightarrow \neg r\} \\ LDR(A_3) &= \{f_1 \Rightarrow p; p \Rightarrow q\} \text{ with } LDR(A_4) = \{f_2 \Rightarrow \neg r\} \end{aligned}$$

If the rules are in increasing order of priority ordered as $f_1 \Rightarrow p < f_2 \Rightarrow \neg r < p \Rightarrow q$, then with the last-link ordering, by comparing sets on their minimal elements, we obtain that $A_3 \prec A_4$ and $A_5 \prec A_2$. Then, in $DeLP$, the attacks of A_2 on A_5 and A_4 on A_3 succeed as proper defeats, so A_1, A_2 and A_4 are warranted while A_3 and A_5 are not warranted. Thus, the set of warranted arguments is not strictly closed and not indirectly consistent.

We can conclude from this example that $DeLP$'s strong consistency requirement on arguments does not in general suffice for satisfying strict closure and indirect consistency.

5 Comparing the Attack Relations

In order to compare the attack relations of $DeLP$ and $ASPIC^+$, we first define an $ASPIC^+$ counterpart of $DeLP$ rebuttal.

Definition 21 (dlp-rebutting attack)

A dlp -rebutts B iff for some $B' \in Sub(B)$ it holds that $Conc(A) \cup Conc(B) \cup \mathcal{K}$ is indirectly inconsistent.

It is easy to verify for $ASPIC^+$ that rebut implies unrestricted rebut and unrestricted rebut implies dlp -rebut. Counterexamples to the converse implications can easily be constructed.

Next, we address the question whether adopting dlp -rebut (but not $DeLP$'s strong consistency condition) could improve $ASPIC^+$. So, in the remainder of this section,

we assume all definitions of ASPIC⁺ except that rebutting attack is replaced with dlp-rebutting attack. In particular, we do for now not require that arguments are non-contradictory in the sense of Definition 14(2).

For complete, preferred, and stable semantics, the answer to our question arguably is negative, as can be shown with the following example, inspired by an example of Caminada and Wu (2011), who read it as “any two of three persons can ride on a tandem together, but they cannot ride the tanden together all three of them.”

Example 11

Consider an ASPIC⁺ AT with $\mathcal{K} = \{f_1, f_2, f_3\}$ and $\mathcal{R}_s = \{p, q \rightarrow \neg r; p, r \rightarrow \neg q; q, r \rightarrow \neg p\}$ and \mathcal{R}_d consisting of the defeasible rules in the following arguments:

- A: $f_1 \Rightarrow p$
- B: $f_2 \Rightarrow q$
- C: $f_3 \Rightarrow r$
- A + B: $A, B \rightarrow \neg r$
- A + C: $A, C \rightarrow \neg q$
- B + C: $B, C \rightarrow \neg p$

With DeLP rebut, A+B and C rebut each other, A+C and B rebut each other, and B+C and A rebut each other. If all arguments are incomparable in the argument ordering, then all these attacks succeed as defeats, so there exists an admissible set containing all of A, B, and C, which violates strict closure and indirect consistency. Note that \mathcal{R}_s is closed under transposition. On the other hand, the grounded extension is $\{f_1, f_2, f_3\}$, which is strictly closed and indirectly consistent.

This example shows that if satisfying strict closure and indirect consistency is regarded as desirable, then adopting dlp-rebut in ASPIC⁺ is not in general an improvement but may be an improvement in special cases. The example also shows that adopting dlp-rebut affects the set of extensions in at least complete, preferred, and stable semantics even if the strict rules are closed under transposition.

Caminada et al. (2014) prove for unrestricted rebut (see Definition 8 above) that for a limited case with a total preference ordering on the set of defeasible rules and a weakest-or last-link argument ordering, the grounded extension satisfies both strict closure and indirect consistency (under the assumption that the set of strict rules is closed under transposition). Since unrestricted rebut and dlp-rebut are similar, it is interesting to see if similar results can be obtained for dlp-rebut. We first investigate this for the so-called *simple argument ordering*, which is such that $A \preceq B$ iff A is defeasible and B is strict.

Direct consistency can be easily shown on the assumption that \mathcal{K} is indirectly consistent.

Proposition 12

Suppose attack in ASPIC⁺ is dlp-rebut, \mathcal{K} is indirectly consistent and the argument ordering is simple. Then for any AF corresponding to a SAF with grounded extension E, it holds that there is no φ such that both φ and $\neg\varphi$ are in $\text{Concs}(E)$.

Proof

Suppose for contradiction $\varphi, \neg\varphi \in \text{Conc}(E)$. Then there exist two arguments A and B in E such that $\text{Conc}(A) = \varphi$ and $\text{Conc}(B) = \neg\varphi$. Since \mathcal{K} is assumed to be indirectly

consistent, at least one of A and B is defeasible. Assume without loss of generality that B is defeasible. Then $A \not\prec B$ so A defeats B . But then E is not conflict free. \square

However, unlike in the case studied by Caminada et al. (2014), there are counterexamples to strict closure and indirect consistency for $ASPIC^+$ with dlp-rebut even if \mathcal{K} is indirectly consistent and \mathcal{R}_s is closed under transposition.

Example 13

Let $\mathcal{K} = \{t\}$ and $\mathcal{R}_d = \{\Rightarrow a_1, \Rightarrow a_2, \Rightarrow q\}$ while \mathcal{R}_s consists of the following rules:

$$\begin{array}{llllll}
 a_1, a_2 \rightarrow p & p, q \rightarrow r & p, q \rightarrow \neg r & t, r \rightarrow s & t, r \rightarrow \neg s \\
 a_1, \neg p \rightarrow \neg a_2 & p, \neg r \rightarrow \neg q & p, r \rightarrow \neg q & t, \neg s \rightarrow \neg r & t, s \rightarrow \neg r \\
 a_2, \neg p \rightarrow \neg a_1 & q, \neg r \rightarrow \neg p & q, r \rightarrow \neg p & r, \neg s \rightarrow \neg t & r, s \rightarrow \neg t \\
 \\
 t, \neg r \rightarrow u & t, \neg r \rightarrow \neg u & & & \\
 t, \neg u \rightarrow r & t, u \rightarrow r & & & \\
 \neg r, \neg u \rightarrow \neg t & \neg r, u \rightarrow \neg t & & &
 \end{array}$$

We first show that arguments $\Rightarrow a_1$ and $\Rightarrow a_2$ are in the grounded extension but $\Rightarrow a_1, \Rightarrow a_2 \rightarrow p$ is not.

Consider first argument $\Rightarrow a_1$. This argument has several defeaters. All of them combine the arguments for p and q to conclude either r or $\neg r$ and then combine the resulting argument for either r or $\neg r$ with the argument for q into an argument for $\neg p$. This argument then is with $\Rightarrow a_2$ combined into an argument for $\neg a_1$. These complex arguments all have a strict defeater, namely t , since t together with r implies s and $\neg s$ while t together with $\neg r$ implies u and $\neg u$. Note that t is strictly preferred over all arguments it dlp-rebut, since t is strict while all arguments it dlp-rebut are defeasible. Since t , being strict, has no defeaters by consistency of \mathcal{K} , there is a winning strategy in the grounded game for $\Rightarrow a_1$, so $\Rightarrow a_1$ is in the grounded extension.

The proof that $\Rightarrow a_2$ is in the grounded extension is entirely similar.

We next show that $\Rightarrow a_1, \Rightarrow a_2 \rightarrow p$ is not in the grounded extension. Call this argument A . It is dlp-rebutted by argument C of the form $\Rightarrow q$. Since both A and C are defeasible, they defeat each other. Next, observe that there is no strict defeater of C , since all dlp-rebuttals of C need the argument for p as a subargument, which is defeasible. So there is no winning strategy for A in the grounded game, so A is not in the grounded extension.

Note that this also yields a counterexample if the set of defeasible rules is totally ordered and arguments are compared with the weakest- or last-link argument ordering as in Caminada et al. (2014), since we can then give all four defeasible rules equal priority.

Note that various arguments in the example are contradictory in the sense of Definition 14(2), so imposing *DeLP*'s consistency condition on arguments (by requiring that the set of all conclusions of all their subarguments is indirectly consistent) excludes this counterexample for *DeLP*. However, other counterexamples for *DeLP* exist, for instance, Example 10 from Section 4.3. If strict closure and indirect consistency are regarded as desirable, then this is worrying not just for *DeLP* but also for $ASPIC^+$ since with the original $ASPIC^+$ definition of rebuttal strict closure and indirect consistency can, as noted above, for the full case with preferences not be shown without allowing inconsistent arguments. We have now seen that replacing rebut with dlp-rebut does not change

this, so as regards strict closure and indirect consistency the current state of the art for ASPIC⁺ is still suboptimal.

6 Differences in Argument Evaluation

While the *DeLP* definition of warrant is similar to grounded semantics, there are also differences, caused by the fact that the constraints on argument lines (Definition 18) do not coincide with the constraints on games in the game-theoretic proof theory for grounded semantics (Definition 1). The choices made on the definition of argumentation lines by García and Simari (2004) establish constraints based on particular intuitions that were shown in examples. However, we believe this definition of argumentation lines has some arguably counterintuitive consequences over the set of warranted literals. We will discuss them below and then show that adopting grounded semantics avoids these counterintuitive consequences.

6.1 Having to move a proper defeater after a blocking defeater

Condition (4) of the definition of an acceptable argument line requires the move of a proper defeater if the previous argument was a blocking defeater, regardless whether the previous argument was a supporting or an interfering argument. This differs from the grounded game, in which the proponent must move strict defeaters while the opponent can move weak defeaters.

Example 14

Consider a dlp with $\Pi_f = \{p, s, u\}$, $\Pi_s = \emptyset$ and Δ consisting of the rules of the following arguments:

$$\begin{array}{ll} A_1: & \langle \{q \multimap p\}, q \rangle & A_2: & \langle \{q \multimap p; r \multimap q\}, r \rangle \\ B_1: & \langle \{t \multimap s\}, t \rangle & B_2: & \langle \{t \multimap s; \neg r \multimap t\}, \neg r \rangle \\ C: & \langle \{\neg t \multimap u\}, \neg t \rangle & & \end{array}$$

A_2 and B_2 attack each other on $\neg r$ and r , while C attacks B_1 and thus also B_2 on t . Assume an argument ordering that makes A_2 and B_2 as well as C and B_1 blocking defeaters of each other (e.g., by not assigning any priority to the rules). Then A_2 is not warranted. Its dialectical tree consists of just one argument line, namely A_2, B_2 and A_2 is marked D in this tree. Note that the line cannot be extended with C , since B_2 is a blocking defeater of A_2 while C is not a proper defeater of B_2 .

Assume now an argument ordering in which C and B_1 are still blocking defeaters of each other but in which B_2 is a proper defeater of A_2 (for instance, by giving all rules in B_2 priority over all rules in A_2). Then A_2 is warranted, since its dialectical tree again consists of just one argument line but now it is A_2, B_2, C and A_2 is marked U in this tree. Note that the line cannot be extended with B_1 since C is a blocking defeater of B_2 while B_1 is not a proper defeater of C .

So by strengthening B 's attack on A , A turns from not warranted into warranted, which seems counterintuitive. This example could be analyzed from the reverse perspective of A being warranted and debilitating B to a blocking defeater will lead to A not being warranted. This clash of intuitions becomes an interesting issue to study, and a possible

avenue for doing so is to adopt the grounded game because supporting arguments have to be strict defeaters while interfering arguments can be weak defeaters. According to the grounded game, A_2 is not justified with the second argument ordering, since the line A_2, B_2, C can be extended with B_1 after which C is not allowed since it is not a strict defeater of B_1 .

6.2 The non-repetition rule

Suppose that in line with our analysis of Example 14 condition (3) of acceptable argument lines is changed to the effect that supporting arguments must be strict defeaters while interfering arguments can be weak defeaters. Then in Example 14 argument A_2 is still warranted with the second argument ordering, since the line A_2, B_2, C cannot be extended with B_1 for another reason: B_1 is a subargument of an argument already moved in the line, namely B_2 , so condition (2) of acceptable argument lines prevents extending the line with B_1 . So this condition could also be changed by adopting the rule of the grounded game that only the proponent cannot repeat its arguments. Moreover, this non-repetition rule might not be extended to proper subarguments of an already-moved argument, as shown by the following example.

Example 15

Consider a dlp with $\Pi_f = \{f_1, f_2, f_3, f_4\}$, $\Pi_s = \emptyset$ and \mathcal{R}_d consists of the rules of the following arguments. Assume also that arguments are ordered according to strict specificity relations between the conflicting rules.

- $A: \langle \{p \multimap f_1\}, p \rangle$
 $B: \langle \{q \multimap f_2; \neg p \multimap q\}, \neg p \rangle$
 $C: \langle \{r \multimap f_3, f_4; s \multimap r; \neg q \multimap s, f_2\}, \neg q \rangle$
 $D: \langle \{\neg r \multimap f_4; \neg s \multimap \neg r\}, \neg s \rangle$

Note that A and B weakly defeat each other, C strictly defeats B on its subargument for q , and D strictly defeats C by weakly defeating its subargument for s . Now there is a strict defeater of D , namely

$$E: \langle \{r \multimap f_3, f_4\}, r \rangle$$

However, E is a subargument of C , so if constraint (3) on argument lines is adopted in the grounded game, then the game loses completeness, since A and C are in the grounded extension. Note that the non-repetition rule of the grounded game does not prevent the moving of E , since E is not identical to C .

We next show that *DeLP*'s non-repetition rule can in combination with the other *DeLP* constraints on argument lines make that the set of warranted arguments is not admissible in the sense of Dung (1995).

Example 16

Consider a dlp with $\Pi_f = \{f_1, f_2, f_3, f_4, f_5\}$, $\Pi_s = \emptyset$ and \mathcal{R}_d consists of the rules of the following arguments. Assume also that arguments are ordered according to strict specificity relations between the conflicting rules.

- A: $\langle \{p \multimap f_1\}, p \rangle$
- B: $\langle \{r \multimap f_2; s \multimap r, f_5; t \multimap s; \neg p \multimap t, f_1\}, \neg p \rangle$
- C: $\langle \{u \multimap f_3; \neg t \multimap u\}, \neg t \rangle$
- D: $\langle \{w \multimap f_4; \neg u \multimap w, f_3\}, \neg u \rangle$
- E: $\langle \{\neg s \multimap f_5; \neg w \multimap \neg s, f_4\}, \neg w \rangle$

According to specificity, *B* is a proper defeater of *A*, *C* is a blocking defeater of *B*, *D* is a proper defeater of *C*, and *E* is a proper defeater of *D*. So *A, B, C, D, E* is an acceptable argument line.

Here the argument line terminates, while there is a proper defeater of *E*, namely

$$F: \langle \{r \multimap f_2; s \multimap r\}, s \rangle$$

But *F* cannot be appended to the argument line since it is a subargument of *B*. So *A* is warranted. Moreover, it is easy to see that *C*, which is a supporting argument for *A*, is not warranted, because of the argument line

- C: $\langle \{u \multimap f_3; \neg t \multimap u\}, \neg t \rangle$
- D: $\langle \{w \multimap f_4; \neg u \multimap w, f_3\}, \neg u \rangle$
- E: $\langle \{\neg s \multimap f_5; \neg w \multimap \neg s, f_4\}, \neg w \rangle$
- F: $\langle \{r \multimap f_2; s \multimap r\}, s \rangle$

Note that here *F* can be appended to *C, D, E*, since *A* is not in this line.

In sum, we have that *A* is warranted even though there is no warranted supporting argument that defends *A* against its defeater *B*. So we end up with a set of warranted arguments that is not admissible in the sense of [Dung \(1995\)](#). If admissibility is accepted as a minimum rationality constraint on argument evaluation, then this is another reason to adopt grounded semantics for *DeLP*.

García and Simari motivate their non-repetition rule with an example that has essentially the same structure as [Example 9](#). In this example, they want to prevent infinite argumentation lines. The grounded game indeed prevents this: the only possible game for *A*₂ is *P*₁: *A*₂, *O*₁: *B*₂ and the game terminates with a win by *O* since *P* cannot repeat its argument *A*₂.

García and Simari motivate the subargument part of their non-repetition rule with a schematic example of the following form (leaving the rules implicit):

Example 17

Consider the following arguments, where each argument *X*₁ is a subargument of *X*₂:

- $\langle \{A_1\}, p \rangle$ $\langle \{A_2\}, \neg r \rangle$
- $\langle \{B_1\}, q \rangle$ $\langle \{B_2\}, \neg p \rangle$
- $\langle \{C_1\}, s \rangle$ $\langle \{C_2\}, \neg q \rangle$
- $\langle \{D_1\}, \neg p \rangle$ $\langle \{D_2\}, \neg s \rangle$

Assuming that the other constraints on argumentation lines are satisfied, they want to prevent the infinite line *A*₂, *B*₂, *C*₂, *D*₂, *A*₁, *B*₂, ... In the grounded game, this is indeed achieved, since the proponent is not allowed to repeat *C*₂ in attack on *B*₂.

We conclude that the non-repetition rule of the grounded game treats all of García and Simari's examples in the way they want and avoids the arguably counterintuitive outcomes of *DeLP* in other examples.

6.3 Concordance

Constraint (2) on argument lines requires both the set of all supporting and the set of all interfering arguments in the line to be concordant, which means that the set of all rules of all these arguments must be consistent with the facts. If the dlp satisfies [Caminada and Amgoud's 2007](#) rationality postulate of strict closure (saying that the set of all conclusions of all arguments in an extension must be indirectly consistent), then for the set of supporting arguments the requirement of concordance is a semantically redundant but computationally desirable addition to the grounded game: redundant since if an argument is warranted/justified, then all of proponent's arguments in a winning strategy for the argument will be in the grounded extension and will thus satisfy concordance; and desirable since it may prune the search space. However, otherwise concordance for supporting arguments can make a difference. In such cases, there seems to be no clear reason why either adopting or not adopting concordance is better.

However, for the set of interfering arguments requiring concordance is arguably undesirable, as the following example shows.

Example 18

Consider a dlp with $\Pi_f = \{f_1, f_2, f_3, f_4\}$, $\Pi_s = \emptyset$ and \mathcal{R}_d consists of the rules of the following arguments. Assume also that arguments are ordered according to strict specificity relations between the conflicting rules.

$$\begin{aligned} A: & \langle \{p \multimap f_1\}, p \rangle \\ B: & \langle \{q \multimap f_2; \neg p \multimap q\}, \neg p \rangle \\ C: & \langle \{r \multimap f_3; \neg q \multimap r, f_2\}, \neg q \rangle \\ D: & \langle \{\neg q \multimap f_4; \neg r \multimap \neg q\}, \neg r \rangle \end{aligned}$$

The dialectical tree for A has just one line, viz. A, B, C . Note that D cannot be appended to the line since B and D support contradictory (sub)conclusions q and $\neg q$. So A is warranted. Yet C , which supports A , is not warranted, since the line C can be extended with D . Note also that $\{A\}$ is not an admissible set since it does not defend A against B while $\{A, C\}$ is not an admissible set, since it does not defend C against D .

If admissibility is adopted as a minimum constraint on sets of warranted arguments, then this example shows that concordance for the set of interfering arguments is undesirable. In other words, arguing in favor of concordance for the set of interfering arguments requires arguing against admissibility as a minimum requirement on sets of warranted arguments. A less controversial solution is to adopt the game for grounded semantics, which, as shown above, is arguably also a good idea for other reasons.

Example 19

Consider the following arguments, built from the rules in the previous example, where each argument X_1 is a subargument of X_2 :

$$\begin{aligned} \langle \{A_1\}, p \rangle & \quad \langle \{A_2\}, \neg r \rangle \\ \langle \{B_1\}, q \rangle & \quad \langle \{B_2\}, \neg p \rangle \\ \langle \{C_1\}, r \rangle & \quad \langle \{C_2\}, \neg q \rangle \end{aligned}$$

Assuming that the other constraints on argumentation lines are satisfied, they want to prevent the line A_2, B_2, C_2, A_2 . In the grounded game this not prevented but this does not make A_2 warranted or the line infinite. The line can (as an argument game) only

be continued with P_3 ; B_2 , O_3 ; C_2 after which the game terminates with a loss by the proponent since he cannot repeat A_2 . So the grounded game satisfies García and Simari's intuitions about this example.

6.4 Reformulating DeLP with grounded semantics

We have seen that *DeLP*'s definition of warrant has some arguably counterintuitive outcomes, due to the particular constraints on acceptable argumentation lines. We have also seen that adopting grounded semantics both avoids these outcomes and treats García and Simari's motivating examples in the way they want. Therefore and because of the similarities between *DeLP*'s notion of warrant and the grounded argument game, it seems a good idea to develop a version of *DeLP* with its current account of warrant replaced with grounded semantics. This can be done by replacing the current constraints on acceptable argument lines with the rules of the grounded game (where proponent and opponent arguments are, respectively, equated with supporting and interfering arguments), and by replacing proper and blocking defeat with strict defeat and defeat. Then given the equivalence noted at the end of Section 3.3, either the grounded game or an accordingly modified definition of dialectical trees can be used to redefine warrant. Thus adopting grounded semantics for *DeLP* would also establish clear links between *DeLP* and a large body of other research on formal argumentation. Among other things, it would facilitate a study of the satisfaction of rationality postulates in *DeLP*. Finally, a version of *DeLP* with grounded semantics would in fact adopt the semantics of Simari and Loui (1992), which paper was the original source of inspiration for the development of *DeLP* and which, as noted above, proposes a notion of warrant that was by Dung (1995) shown to be equivalent to grounded semantics.

The question arises whether the move to grounded semantics and leaving all other definitions as they are (let us call the resulting system $DeLP^{(GR)}$) changes anything as regards strict closure and indirect consistency. As it turns out, the answer is no, since Example 10 from Section 4.3 is also for $DeLP^{(GR)}$ a counterexample to satisfaction of strict closure and indirect consistency. The point is that neither A_2 nor A_5 has a defeater, so the grounded game for these arguments ends after the first move. So while the move to $DeLP^{(GR)}$ ensures admissibility of the set of warranted arguments, it does not guarantee strict closure and indirect consistency of the set of warranted conclusions. On the other hand, Proposition 12 applies to $DeLP^{(GR)}$, so the set of warranted conclusions is, as in original *DeLP*, guaranteed to be directly consistent.

7 Correspondence Results

We next study correspondence results between aspects of *DeLP*, $DeLP^{(GR)}$, and $ASPIC^+$. Of all these results, only Proposition 26 will depend on $DeLP^{(GR)}$; all other results hold for both *DeLP* and $DeLP^{(GR)}$. Throughout this section, we will implicitly assume corresponding defeasible logic programs and argumentation theories with the same language and the same sets of rules and facts. That is, we assume that $f \in \mathcal{K}$ just in case $f \in \Pi_f$, that $S \rightarrow \varphi \in \mathcal{R}_s$ just in case $\varphi \leftarrow S \in \Pi_s$ and that $S \Rightarrow \varphi \in \mathcal{R}_s$ just in case $\varphi \multimap S \in \Delta$. Below we will leave the translation between the $ASPIC^+$ and *DeLP* notations implicit.

We first address the problem of finding a correspondence between *DeLP* arguments and $ASPIC^+$ arguments. To find such a correspondence, several assumptions on $ASPIC^+$

argumentation theories are needed, since *DeLP* has unlike *ASPIC*⁺ minimality and consistency conditions on arguments. Accordingly, we define *simplified ASPIC*⁺ argumentation theories as those *AT* in which all arguments *A* are minimal in that if $\text{Conc}(A) = p$ then there exists no argument *A'* such that $\text{Conc}(A') = p$ and $\text{DefRules}(A') \subset \text{DefRules}(A)$; and in which for all arguments *A* the set $\text{Conc}(\text{Sub}(A)) \cup \mathcal{R}_s \cup \mathcal{K}$ is indirectly consistent.

Lemma 20

Let $AT = (AS, \mathcal{K})$ be any *ASPIC*⁺ argumentation theory. For any argument *A* based on *AT* it holds that $\text{Conc}(\text{Sub}(A))$ equals the set of all antecedents and consequents of any rule in $\text{Rules}(A)$.

Proof

Immediate from the definition of an *ASPIC*⁺ argument. □

Proposition 21

Let (Π, Δ) be any defeasible logic program with a corresponding *ASPIC*⁺ argumentation theory (AS, \mathcal{K}) . For any *DeLP* argument $D = \langle R, p \rangle$ given (Π, Δ) there exists an *ASPIC*⁺ argument *A* for *p* on the basis of (AS, \mathcal{K}) with $\text{DefRules}(A) = R$.

Proof

Let $D = \langle R, p \rangle$ be any *DeLP* argument given (Π, Δ) . Then there exists a defeasible derivation $Dd = L_1, \dots, L_n = p$ of *p* given (Π, R) . Assume without loss of generality that *Dd* is minimal. We prove by induction on the definition of defeasible derivations that for any element of *Dd* there exists an *ASPIC*⁺ argument *A* on the basis of (AS, \mathcal{K}) with $\text{DefRules}(A) \subseteq R$.

There are two base cases. If L_i is a fact, then $L_i \in \mathcal{K}$ so L_i is an *ASPIC*⁺ argument with $\text{DefRules}(A) = \emptyset \subseteq R$. If L_i is a presumption, then $\Rightarrow L_i \in \mathcal{R}_d$ so $\Rightarrow L_i$ is an *ASPIC*⁺ argument with $\text{DefRules}(A) = \{\Rightarrow L_i\} \subseteq R$.

The induction hypothesis is that for all elements L_i of *Dd* such that there exists a rule *r* in $\Pi \cup R$ with body B_1, \dots, B_m and head L_i and such that all of B_1, \dots, B_m precede L_i in *Dd* there exists an *ASPIC*⁺ argument C_j for any B_j ($1 \leq j \leq m$) with $\text{DefRules}(C_j) \subseteq R$. For the induction step, consider any such a rule *r* and let the *ASPIC*⁺ arguments for B_1, \dots, B_m be C_1, \dots, C_m . Then if $r \in \Pi$, then $r \in \mathcal{R}_s$, so $C = C_1, \dots, C_m \rightarrow L_i$ is an *ASPIC*⁺ argument with $\text{DefRules}(C) = \text{DefRules}(C_1) \cup \dots \cup \text{DefRules}(C_m) \subseteq R$. Otherwise, $r \in R$ so $r \in \mathcal{R}_d$, so $C_1, \dots, C_m \Rightarrow L_i$ is an *ASPIC*⁺ argument with $\text{DefRules}(C) = \text{DefRules}(C_1) \cup \dots \cup \text{DefRules}(C_m) \cup \{r\} \subseteq R$.

Finally, to prove that $\text{DefRules}(A) = R$, assume for contradiction that there exists a rule $r \in R$ such that $r \notin \text{DefRules}(A)$. Then by Lemma 20 it holds that *r*'s head is not in $\text{Conc}(\text{Sub}(A))$. But consider then the sequence *Dd'* obtained by listing all elements of $\text{Conc}(\text{Sub}(A))$ in any order such that the bodies of any rule precede the rule's head. It is easy to verify that *Dd'* is a defeasible derivation of *p* given (Π, Δ) . But $Dd' \subset Dd$, so *Dd* is not minimal: contradiction. □

Proposition 22

Let (Π, Δ) be any defeasible logic program with a corresponding *ASPIC*⁺ argumentation theory (AS, \mathcal{K}) that is simplified. For any *ASPIC*⁺ argument *A* for *p* on the basis of (AS, \mathcal{K}) there exists a *DeLP* argument $D = \langle \text{DefRules}(A), p \rangle$ given (Π, Δ) .

Proof

Suppose A is an ASPIC⁺ argument for p . There are two base cases. Assume first $A = p$. Then $p \in \Pi_f$ and p is a defeasible derivation since p is a fact. Moreover, since the ASPIC⁺ AT is simplified, $\{p\} \cup \mathcal{R}_s \cup \mathcal{K}$ is indirectly consistent, so (since $\Pi = \mathcal{R}_s \cup \mathcal{K}$), no pair of contradictory literals can be derived from $\Pi \cup \emptyset$. Finally, \emptyset is obviously a minimal subset of Δ satisfying all this. So $D = \langle \emptyset, p \rangle$ is a DeLP argument for p given (Π, Δ) .

Assume next A is of the form $\Rightarrow p$. Then p is a defeasible derivation since $\Rightarrow p \in \Delta$ so p is a presumption. Moreover, since AT is simplified, there exists no strict ASPIC⁺ argument for p so A is minimal in its set of defeasible rules. Then the proof that $D = \langle \{\Rightarrow p\}, p \rangle$ is a DeLP argument for p given (Π, Δ) is similar as for facts.

The induction hypothesis is that for any ASPIC⁺ argument $\{A_1, \dots, A_m\} \rightarrow / \Rightarrow p$ there exist DeLP arguments for $\text{Conc}(A_1), \dots, \text{Conc}(A_m)$ given (Π, Δ) . For the induction step, consider any such ASPIC⁺ argument. Then there exist defeasible derivations Dd_j for all these conclusions $\text{Conc}(A_j)$ ($1 \leq j \leq m$). Then clearly Dd_1, \dots, Dd_m, p is a defeasible derivation for p . Moreover, since the ASPIC⁺ AT is assumed to be simplified, $\text{Conc}(\text{Sub}(A)) \cup \mathcal{K}$ is indirectly consistent and since the heads of all rules in $\text{DefRules}(A)$ are in $\text{Conc}(\text{Sub}(A))$, no pair of contradictory literals can be derived from $\Pi \cup \text{DefRules}(A)$ (recall that $\Pi = \mathcal{R}_s \cup \mathcal{K}$). If there existed a DeLP argument $D = \langle R, p \rangle$ for p such that $R \subset \text{DefRules}(A)$, then by Proposition 21 there would exist an ASPIC⁺ argument A' for p with $\text{DefRules}(A') = R$. But then A would not be minimal in its set of defeasible rules [note that $\text{Conc}(\text{Sub}(A')) \cup \mathcal{K}$ is indirectly consistent since D satisfies the consistency constraint on DeLP arguments]. So then AT would not be simplified, which contradicts our assumption that it is simplified. Thus $D = \langle \text{DefRules}(A), p \rangle$ is a DeLP argument for p given (Π, Δ) . \square

There are counterexamples to Proposition 22 for non-simplified ASPIC⁺ argumentation theories. Some counterexamples are due to DeLP's consistency constraint on arguments. Consider an ASPIC⁺ AT with $\mathcal{K} = \{p\}$ and $\mathcal{R}_d = \{\Rightarrow \neg p\}$. Then there are ASPIC⁺ arguments p for p and $\Rightarrow \neg p$ for $\neg p$ but the latter has no corresponding DeLP argument, since both p and $\neg p$ can be defeasibly derived from $\Pi \cup \{\Rightarrow \neg p\}$ (recall that $\mathcal{K} \in \Pi$). Other counterexamples are due to DeLP's minimality constraint on arguments. Consider an ASPIC⁺ AT with $\mathcal{K} = \{p\}$, $\mathcal{R}_s = \{p \rightarrow q\}$, and $\mathcal{R}_d = \{\Rightarrow q\}$. Then the ASPIC⁺ argument $\Rightarrow p$ for p has no corresponding DeLP argument, since $\langle \emptyset, q \rangle$ is a DeLP argument for q , so $\langle \{\Rightarrow q\}, q \rangle$ is not minimal.

It can be shown that the correspondence between ASPIC⁺ and DeLP arguments is many-to-one.

Proposition 23

Let (Π, Δ) be any defeasible logic program with a corresponding ASPIC⁺ argumentation theory (AS, \mathcal{K}) that is simplified.

1. For some DeLP arguments given (Π, Δ) , there exist more than one corresponding ASPIC⁺ arguments on the basis of (AS, \mathcal{K}) .
2. For all ASPIC⁺ arguments (AS, \mathcal{K}) , there exists a unique corresponding DeLP argument given (Π, Δ) .

Proof

For (1) consider an example with $\Pi_f = \{p; r; q \leftarrow p; q \leftarrow r\}$ and $\Delta = \{s \multimap q\}$. The *DeLP* argument $\{s \multimap q\}$ for s has two corresponding *ASPIC*⁺ arguments $A_1 = [p \rightarrow q] \Rightarrow s$ and $A_2 = [p \rightarrow r] \Rightarrow s$.

(2) follows since each *ASPIC*⁺ argument has a unique set of defeasible rules and uses all these rules, while *DeLP* arguments are defined by minimal sets of defeasible rules. Then the construction in the proof of Proposition 22 clearly induces a unique *DeLP* argument. \square

We next prove correspondences with respect to the attack relations. To this end, we first define *DeLP*-counterparts of *ASPIC*⁺'s rebutting and unrestricted rebutting attacks.

Definition 22 (a-rebutting and ua-rebutting attack)

A *DeLP* argument $\langle A, p \rangle$ *a-rebuts* a *DeLP* argument $\langle B, q \rangle$ on $\langle B', q' \rangle$ if $\langle B', q' \rangle$ is a subargument of $\langle B, q \rangle$ and $p = -q'$ and q' was derived in $\langle B', q' \rangle$ with a defeasible rule.

A *DeLP* argument $\langle A, p \rangle$ *ua-rebuts* a *DeLP* argument $\langle B, q \rangle$ on $\langle B', q' \rangle$ if $\langle B', q' \rangle$ is a subargument of $\langle B, q \rangle$ and $p = -q'$ and $B' \neq \emptyset$.

In the proofs of the following propositions, we overload the symbol \subseteq by writing for two *DeLP* arguments $D_1 = \langle S_1, p \rangle$ and $D_2 = \langle S_2, q \rangle$ that $D_1 \subseteq D_2$ to mean that $S_1 \subseteq S_2$. Likewise for other set-theoretic notations.

Proposition 24

For all *ASPIC*⁺ arguments A and A' on the basis of a simplified argumentation theory, it holds that if A is (rebutted, u-rebutted, dlp-rebutted) by A' then the *DeLP* argument D corresponding to A is (a-rebutted, ua-rebutted, rebutted) by the *DeLP* argument D' corresponding to A' .

Proof

Suppose *ASPIC*⁺ argument A' for p' rebuts, u-rebuts, or dlp-rebuts *ASPIC*⁺ argument A on A'' for p . Consider the corresponding *DeLP* arguments D' for p' and D'' for p , which exist and are unique by Proposition 22. Note that $D'' \subseteq D$ by Proposition 22 since $\text{DefRules}(A'') \subseteq \text{DefRules}(A)$.

For rebut, $p = -p'$ while p' was derived in A'' with A'' defeasible top rule. Since A'' 's top rule is in D'' , D' a-rebuts D'' since p and p' are complementary literals. But then D' a-rebuts D since $D'' \subseteq D$.

For u-rebut, $p = -p'$ while $\text{DefRules}(A'') \neq \emptyset$. Then by Proposition 22 it holds that $D'' \neq \emptyset$. Then D' ua-rebuts D'' since p and p' are complementary literals. But then D' ua-rebuts D since $D'' \subseteq D$.

For dlp-rebut, $\mathcal{K} \cup \{p, p'\}$ is indirectly inconsistent. Then in *DeLP* the set $\Pi \cup \{p, p'\}$ is contradictory. Then D' rebuts D'' . But then D' rebuts D since $D'' \subseteq D$. \square

Proposition 25

For all *DeLP* arguments D and D' based on any defeasible logic program it holds that if D is (rebutted, a-rebutted, ua-rebutted) by D' then all *ASPIC*⁺ arguments A corresponding to D are (dlp-rebutted, rebutted, u-rebutted) by any *ASPIC*⁺ argument A' corresponding to D' .

Proof

Suppose D' for p' rebuts, a-rebuts, or ua-rebuts D on D'' for p . Consider any ASPIC⁺ argument A corresponding to D and A' corresponding to D' , which exist by Proposition 22. By the same proposition, $\text{DefRules}(A) = D$ and $\text{DefRules}(A') = D'$.

For rebut, $\Pi \cup \{p, p'\}$ is contradictory, that is, there exists a defeasible derivation for two literals h and $-h$ from this set. Note that such a defeasible derivation is strict since the set contains no defeasible rules. Then in ASPIC⁺ the set $\mathcal{K} \cup \{p, p'\}$ is indirectly inconsistent. By Lemma 20 and the fact that $\text{DefRules}(A) = D$, we have that $p \in \text{Conc}(\text{Sub}(A))$ and $p' \in \text{Conc}(\text{Sub}(A'))$. Then A' dlp-rebuts A .

For a-rebut, p and p' are complementary literals while p' was derived in D'' with a defeasible rule. Then $p = -p'$. By Lemma 20 and the fact that $\text{DefRules}(A) = D$, we have that $p \in \text{Conc}(\text{Sub}(A))$. Moreover, by construction of A , p is derived in A with a defeasible rule. Then A' a-rebuts some subargument of A so A' a-rebuts A .

For ua-rebut, p and p' are complementary literals while $D'' \neq \emptyset$. Then $p = -p'$. By Lemma 20 and the fact that $\text{DefRules}(A) = D$, we have that $p \in \text{Conc}(\text{Sub}(A))$. Then A' a-rebuts some subargument of A so A' a-rebuts A . \square

Propositions 21, 22, 24, and 25 together imply the following proposition (recall that $DeLP^{(GR)}$ is the variant of $DeLP$ modified with grounded semantics).

Proposition 26

Let (Π, Δ) be any defeasible logic program with a corresponding ASPIC⁺ argumentation theory (AS, \mathcal{K}) that is simplified. Let the $DeLP^{(GR)}$ and ASPIC⁺ orderings coincide in that for all $DeLP^{(GR)}$ arguments D_1 and D_2 it holds that $D_1 \prec D_2$ iff for all corresponding ASPIC⁺ arguments A_1 and A_2 it holds that $A_1 \prec A_2$ and for all ASPIC⁺ arguments A_1 and A_2 it holds that $A_1 \prec A_2$ iff for the corresponding $DeLP$ arguments D_1 and D_2 it holds that $D_1 \prec D_2$. Let also $DeLP^{(GR)}$ attack be rebut (a-rebut, ua-rebut) iff ASPIC⁺ attack is dlp-rebut (rebut, u-rebut). Then any $DeLP^{(GR)}$ argument D is warranted iff all corresponding ASPIC⁺ arguments A are justified and any ASPIC⁺ argument A is justified iff the corresponding $DeLP$ argument D is warranted.

Proof

(Sketch) From left to right, consider any $DeLP$ argument D that is warranted. Then there exists a dialectical tree T^D for D with D labeled U . Consider any corresponding dialectical tree T^A of ASPIC⁺ arguments obtained by replacing any supporting argument in T^D by some corresponding ASPIC⁺ argument and replacing any interfering argument in T^D by all corresponding ASPIC⁺ arguments. By Proposition 25 and our assumptions on the argument orderings, the defeat relations between $DeLP$ arguments in T^A are preserved as defeat relations between the corresponding ASPIC⁺ arguments in T^D . It is left to prove that T^A contains all defeaters of any of its supporting arguments. Assume for contradiction that some defeater B of some supporting argument A in T^A is not in T^A . By Proposition 22 B has a unique corresponding $DeLP$ argument B^d . Then by Proposition 24 and our assumptions on the argument orderings it holds that B^d defeats the $DeLP$ argument A^d corresponding to A . But then B^d is in T^D so B is in T^A . Contradiction.

From right to left, the proof is similar but simpler since any ASPIC⁺ argument has just one corresponding $DeLP$ argument. \square

8 Conclusion

In this paper, we have made detailed comparisons between *DeLP* and *ASPIC*⁺ as formalisms for rule-based argumentation. The comparisons especially focussed on inter-translatability, consistency and closure properties, and intuitive adequacy. Computational and implementational issues were not discussed but from other sources, such as Modgil and Prakken (2018) and García and Simari (2018), it is clear that these issues have received substantially more attention for *DeLP* than for *ASPIC*⁺. Our comparisons have hopefully contributed to a better understanding of the two formalisms and their relations, similarities, and differences.

To summarize our main findings, we have first seen that *DeLP*'s notion of rebutting attack and its consistency and minimality constraints on arguments are intuitively appealing and in some special cases more so than their *ASPIC*⁺ counterparts. However, we have also seen that the *DeLP* definitions may not fully comply with Caminada and Amgoud's rationality postulates of strict closure and indirect consistency in cases where *ASPIC*⁺ satisfies these postulates. In Section 4.1, we have included a thorough discussion about these issues.

Furthermore, we have argued that there are reasons to consider a variant of *DeLP* with grounded semantics, since its current notion of warrant arguably has counterintuitive consequences in some examples and in general leads to sets of warranted arguments that are not admissible. We have seen that both problems can be avoided by adopting the argument game for grounded semantics in *DeLP*. A version of *DeLP* with grounded semantics would also be a return to the semantics of Simari and Loui (1992), which paper was the original source of inspiration for the development of *DeLP*. Arguing in defence of *DeLP*'s current notion of warrant requires arguing, first, that its treatment of Example 14 is not counterintuitive and second, that admissibility is not a minimum requirement for sets of warranted arguments. Alternatively, if one agrees that Example 14 is treated incorrectly by *DeLP* but not that admissibility must be satisfied by warrant, then less substantial changes in the definition of acceptable argument lines might suffice.

Finally, we have under some minimality and consistency assumptions on *ASPIC*⁺ arguments identified a one-to-many mapping between *DeLP* arguments and *ASPIC*⁺ arguments in such a way that if *DeLP* is modified with grounded semantics, then the resulting *DeLP*^(GR)'s notion of warrant is equivalent to *ASPIC*⁺'s notion of justification. This result was proven for three alternative definitions of attack.

As for future research, since *DeLP*^(GR) generates abstract argumentation frameworks, it can be investigated to which extent properties of *DeLP*^(GR) depend on grounded semantics or are inherited by other semantics for AFs. Future research could also investigate whether incorporating *DeLP*'s notion of rebutting attack and/or its consistency and minimality requirements on arguments in *ASPIC*⁺ can be done in a way that fully preserves the current results on how *ASPIC*⁺ respects the various rationality postulates. Given the results in this paper, this would require further changes in the *ASPIC*⁺ framework.

References

- AMGOUD, L. AND BESNARD, P. 2013. Logical limits of abstract argumentation frameworks. *Journal of Applied Non-classical Logics* 23, 229–267.

- AMGOUD, L., BODENSTAFF, L., CAMINADA, M., MCBURNEY, P., PARSONS, S., PRAKKEN, H., VAN VEENEN, J. AND VREESWIJK, G. 2006. Final review and report on formal argumentation system. Deliverable D2.6, ASPIC IST-FP6-002307.
- BARONI, P., CAMINADA, M. AND GIACOMIN, M. 2011. An introduction to argumentation semantics. *The Knowledge Engineering Review* 26, 365–410.
- BARONI, P., CAMINADA, M. AND GIACOMIN, M. 2018. Abstract argumentation frameworks and their semantics. In *Handbook of Formal Argumentation*, P. Baroni, D. Gabbay, M. Giacomin, and L. van der Torre, Eds, vol. 1. College Publications, London, 157–234.
- BESNARD, P. AND HUNTER, A. 2001. A logic-based theory of deductive arguments. *Artificial Intelligence* 128, 203–235.
- BESNARD, P. AND HUNTER, A. 2008. *Elements of Argumentation*. MIT Press, Cambridge, MA.
- CAMINADA, M. AND AMGOUD, L. 2007. On the evaluation of argumentation formalisms. *Artificial Intelligence* 171, 286–310.
- CAMINADA, M., MODGIL, S. AND OREN, N. 2014. Preferences and unrestricted rebut. In *Computational Models of Argument. Proceedings of COMMA 2014*, S. Parsons, N. Oren, C. Reed, and F. Cerutti, Eds. IOS Press, Amsterdam etc, 209–220.
- CAMINADA, M. AND WU, Y. 2011. On the limitations of abstract argumentation. In *Proceedings of the 23rd Benelux Conference on Artificial Intelligence (BNAIC-11)*, Gent, Belgium.
- CAYROL, C. 1995. On the relation between argumentation and non-monotonic coherence-based entailment. In *Proceedings of the 14th International Joint Conference on Artificial Intelligence*, 1443–1448.
- COHEN, A., GARCÍA, A. J. AND SIMARI, G. R. 2016. A structured argumentation system with backing and undercutting. *Engineering Applications of AI* 49, 149–166.
- DUNG, P. 1995. On the acceptability of arguments and its fundamental role in nonmonotonic reasoning, logic programming, and *n*-person games. *Artificial Intelligence* 77, 321–357.
- GARCÍA, A. J., CHESÑEVAR, C. I. AND SIMARI, G. R. 1993. Making argument systems computationally attractive. In *Proceedings of the XIII International Congress of the Chilean Computer Science Society*.
- GARCÍA, A. J. AND SIMARI, G. R. 2004. Defeasible logic programming: An argumentative approach. *Theory and Practice of Logic Programming* 4, 95–138.
- GARCÍA, A. J. AND SIMARI, G. R. 2014. Defeasible logic programming: DeLP-servers, contextual queries, and explanations for answers. *Argument and Computation* 5, 63–88.
- GARCÍA, A. J. AND SIMARI, G. R. 2018. Argumentation based on logic programming. In *Handbook of Formal Argumentation*, P. Baroni, D. Gabbay, M. Giacomin, and L. van der Torre, Eds, vol. 1. College Publications, London, 408–433.
- GARCÍA, A. J., SIMARI, G. R. AND CHESÑEVAR, C. I. 1998. An argumentative framework for reasoning with inconsistent and incomplete information. In *Proceedings of the ECAI'98 Workshop on Practical Reasoning and Rationality*, Brighton, UK.
- GARCÍA, A. J. 2000. Defeasible Logic Programming: Definition, Operational Semantics and Parallelism. Ph.D. thesis, Computer Science and Engineering Department, Universidad Nacional del Sur, Bahía Blanca, Argentina.
- GARCÍA, A. J., CHESÑEVAR, C. I., ROTSTEIN, N. D. AND SIMARI, G. R. 2013. Formalizing dialectical explanation support for argument-based reasoning in knowledge-based systems. *Expert Systems with Applications* 40, 8, 3233–3247.
- GARCÍA, A. J., ROTSTEIN, N. D., TUCAT, M. AND SIMARI, G. R. 2007. An argumentative reasoning service for deliberative agents. In *Knowledge Science, Engineering and Management, Second International Conference, KSEM 2007*, Z. Zhang and J. H. Siekmann, Eds. Lecture Notes in Computer Science, vol. 4798. Springer, 128–139.
- GOROGIANNIS, N. AND HUNTER, A. 2011. Instantiating abstract argumentation with classical-logic arguments: postulates and properties. *Artificial Intelligence* 175, 1479–1497.

- LIFSCHITZ, V. 1996. Foundations of logic programs. In *Principles of Knowledge Representation*, G. Brewka, Ed. CSLI Publications, 69–128.
- MARTÍNEZ, M. V., GARCÍA, A. J. AND SIMARI, G. R. 2012. On the use of presumptions in structured defeasible reasoning. In *Computational Models of Argument. Proceedings of COMMA 2012*, B. Verheij, S. Szeider, and S. Woltran, Eds. Frontiers in Artificial Intelligence and Applications, vol. 245. IOS Press, 185–196.
- MODGIL, S. AND CAMINADA, M. 2009. Proof theories and algorithms for abstract argumentation frameworks. In *Argumentation in Artificial Intelligence*, I. Rahwan and G. Simari, Eds. Springer, Berlin, 105–129.
- MODGIL, S. AND PRAKKEN, H. 2013. A general account of argumentation with preferences. *Artificial Intelligence* 195, 361–397.
- MODGIL, S. AND PRAKKEN, H. 2014. The ASPIC+ framework for structured argumentation: A tutorial. *Argument and Computation* 5, 31–62.
- MODGIL, S. AND PRAKKEN, H. 2018. Abstract rule-based argumentation. In *Handbook of Formal Argumentation*, P. Baroni, D. Gabbay, M. Giacomin, and L. van der Torre, Eds, vol. 1. College Publications, London, 73–141.
- NELKIN, D. 2000. The lottery paradox, knowledge, and rationality. *The Philosophical Review* 109, 373–409.
- PARSONS, S. AND COHEN, A. 2018. On the relationship between DeLP and ASPIC+. In *Argumentation-based Proofs of Endearment. Essays in Honor of Guillermo R. Simari on the Occasion of his 70th Birthday*, C. Chesñevar et al., Ed. College Publications, London, 293–323.
- POLLOCK, J. 1987. Defeasible reasoning. *Cognitive Science* 11, 481–518.
- POLLOCK, J. 1995. *Cognitive Carpentry. A Blueprint for How to Build a Person*. MIT Press, Cambridge, MA.
- PRAKKEN, H. 1999. Dialectical proof theory for defeasible argumentation with defeasible priorities (preliminary report). In *Formal Models of Agents*, J.-J. Meyer and P.-Y. Schobbens, Eds. Number 1760 in Springer Lecture Notes in AI. Springer Verlag, Berlin, 202–215.
- PRAKKEN, H. 2010. An abstract framework for argumentation with structured arguments. *Argument and Computation* 1, 93–124.
- PRAKKEN, H. 2016. Rethinking the rationality postulates for argumentation-based inference. In *Computational Models of Argument. Proceedings of COMMA 2016*, P. Baroni, T. Gordon, T. Scheffler and M. Stede, Eds. IOS Press, Amsterdam etc, 419–430.
- SIMARI, G. R. AND LOUI, R. 1992. A mathematical treatment of defeasible argumentation and its implementation. *Artificial Intelligence* 53, 125–157.
- SIMARI, G. R., CHESÑEVAR, C. I. AND GARCÍA, A. J. 1994a. Focusing inference in defeasible argumentation. In *IV Iberoamerican Conference on Artificial Intelligence. IBERAMIA'94*.
- SIMARI, G. R., CHESÑEVAR, C. I. AND GARCÍA, A. J. 1994b. The role of dialectics in defeasible argumentation. In *XIV International Conference of the Chilean Computer Society, November 1994, Concepción, Chile*, 111–122.
- TEZE, J. C., GOTTIFREDI, S., GARCÍA, A. J. AND SIMARI, G. R. 2015. Improving argumentation-based recommender systems through context-adaptable selection criteria. *Expert Systems with Applications* 42, 21, 8243–8258.
- TUCAT, M., GARCÍA, A. J. AND SIMARI, G. R. 2009. Using defeasible logic programming with contextual queries for developing recommender servers. In *AAAI Fall Symposium Series*.
- VREESWIJK, G. 1997. Abstract argumentation systems. *Artificial Intelligence* 90, 225–279.
- WU, Y. AND PODLASZEWSKI, M. 2015. Implementing crash-resistance and non-interference in logic-based argumentation. *Journal of Logic and Computation* 25, 303–333.