

# PF/LF Convergence in Acquisition<sup>1</sup>

Jacqueline van Kampen

Utrecht University

## 0. Optional PF/LF transparency

A common view on language acquisition assumes that the LAD attains the core grammar of a specific language by fixing parameters of UG in a relatively short time and without support of negative evidence. The high demands of *relatively short time* and *no negative evidence* come in reach by a mediating principle, the *Subset Principle*. This principle protects the LAD against the wide arrays of options that are necessarily opened by the UG parameters. If we look at the acquisition facts, though, it is not possible to accept the Subset Principle. Child language is characterized by parameter options that are not supported by the adult input and that fade out slowly. Their fading out presents a development that moves from a superset to a subset. This paper will present five such cases in which the UG parameter at first appears as an option in child grammar. The spontaneously chosen parameter values seem to be a more direct reflection of the LF representation. The five cases seem to demonstrate the temporary advantage of a reduced PF/LF discrepancy. This leads to the generalization that spontaneous options in child language are potential windows on LF representations.

## 1. Empirical setting

Suppose that LF representations are more uniform across languages than PF representations. And also that there are rules bridging the PF/LF discrepancy. Then, the PF/LF discrepancy may be smaller or bigger, depending mainly on the PF Conditions. It has often been suggested that child language will tend to show constructions that minimize PF/LF discrepancy. For such views, see among others Lightfoot (1979), Klein (1982:195f), Hyams (1986:162f), Roeper (1991:179).

---

<sup>1</sup> This paper is a reduced version of a paper written with Arnold Evers. We are grateful to Peter Coopmans, Nina Hyams, Maaïke Verrips, Fred Weerman and Frank Wijnen for valuable comments. This paper is based on longitudinal data of two Dutch children, Sarah and Laura. The study is funded by the Netherlands Organization of Scientific Research (NWO), project 300-171-027.

JACQUELINE VAN KAMPEN

At least five constructions in Dutch child language support this idea of a reduced PF/LF discrepancy in child language. In each of these constructions a grammatical chain is somehow spelled out in a way more elaborated than allowed in the (adult) target language. Consider the examples in (1). Each example is headed by a brief indication of its deviance from the adult grammar.

- (1) a. Spell-out of hidden <wh>-positions in WH-chains  
*in welk huis*      denk je      *waar* ze wonen?      (S. 4;10)  
in which house    do y. th.    where they live?
- b. Spell-out of hidden positions in NEG-chains  
*niemand*    kan er    *niks*      aan doen      (S. 5;10)  
nobody    can    nothing    do about it
- c. Violation of the Left Branch Condition  
*welke*      wil jij    [*t<sub>wh</sub> liedje*] zingen?      (S. 3;7)  
which      want you      song sing?
- d. Overgeneralization of P<sup>0</sup> stranding  
weet je    *wat* ik [*over t<sub>wh</sub>*] heb gedroomd?      (S. 3;11)  
know you what I about have dreamt?
- e. Evasion of V-2nd by do-insertion  
wat    *doe*    jij      *zeggen*?      (S. 3;4)  
what do you say?

Each of these five constructions in Dutch child language is characterized by the empirical setting in (2).

- (2) *Empirical setting*
- They are not grammatical, at least not fully grammatical, in standard adult Dutch.
  - They appear as possible PF representations in other languages.
  - They have a more analytical PF representation than the adult variant.  
They are optional and fade out slowly.

The adult variants of the examples in (1) are synonyms and appear as well in child Dutch, as free alternatives. Below, each of the five constructions will be shown to fit the empirical setting in (2). Further, it will be argued that the observational data in (1) plausibly lead to the assumption of the structural properties in (3).

## PF/LF CONVERGENCE IN ACQUISITION

### (3) *Grammatical analysis*

- a. The five examples have less PF/LF discrepancy than the adult variants. There is less PF/LF discrepancy if all members of an LF chain are spelled-out in PF ((1)a,b,e) or if there is no pied-piping of phrase material ((1)c,d).
- b. The reduced PF/LF discrepancy follows from a PF parameter on a functional head, respectively  $C^0$ ,  $I^0$ ,  $Neg^0$ ,  $P^0$ ,  $D^0$ .

In each construction two different principles are relevant. The first principle handles the obligatory construction of the LF chain. The second one concerns the PF visibility of the chain.

The PF parameter is optional in child language. Moreover, comparative grammar shows that the optional setting is maintained in the adult variants of some languages. There are adult languages that allow the superset.

The remainder of this paper is organized as follows. In section 2 the five examples illustrated in (1) will be analyzed. On the basis of the empirical setting in (2), we will argue in favor of the grammatical analysis in (3). In section 3 the five  $X^0$  PF parameters will be framed within one generalization. Section 4 discusses some proposals for the theory of grammar and language acquisition.

## 2. Five examples

### 2.1 Spell-out of hidden <wh>-positions in WH-chains

Long distance questions in child language may show the spell-out of an intermediate wh-feature instead of the complementizer *dat* 'that'.<sup>2</sup> Consider (4).

- |     |    |                        |           |             |                   |           |
|-----|----|------------------------|-----------|-------------|-------------------|-----------|
| (4) | a. | <i>in welk huis</i>    | denk je   | <i>waar</i> | ze wonen?         | (S. 4;10) |
|     |    | in which house         | do y. th. | where       | they live?        |           |
|     | b. | <i>op welke manier</i> | denk je   | <i>hoe</i>  | ik een taart bak? | (L. 7;10) |
|     |    | in which way           | do y. th. | how         | I a cake bake?    |           |

*Ad (2)a, ungrammaticality in target language.* In the adult grammar the element *dat* 'that' appears as a constant in the intermediate C-position rather than a wh-pronoun. This is kind of reasonable, since the matrix verb 'think' selects a <-wh> complement.

- |     |    |                        |           |            |                   |
|-----|----|------------------------|-----------|------------|-------------------|
| (5) | a. | <i>in welk huis</i>    | denk je   | <i>dat</i> | ze wonen?         |
|     |    | in which house         | do y. th. | that       | they live?        |
|     | b. | <i>op welke manier</i> | denk je   | <i>dat</i> | ik een taart bak? |
|     |    | in which way           | do y. th. | that       | I a cake bake?    |

---

<sup>2</sup> The constructions with spell-out of a wh-feature have been registered between the following ages. Laura: 7;1.7 - 8;11.18 / Sarah: 4;7.24 - 5;11.

*Ad (2)b, availability in UG.* Nevertheless, child grammar makes use of a potential PF representation. Spell-out of wh-elements is found in the adult language of Afrikaans, Frisian, German dialects, among others (MacDaniel 1986). The PF parameter of intermediate Spec-head agreement must be present in the C-head, cf. Thornton and Crain (1994). See Van Kampen and Evers (1995a) for a discussion. The C<sup>0</sup> is <± wh agr>. Standard adult Dutch has <- wh agr> in C<sup>0</sup>, whereas child language has <+ wh agr>. The positive option in Dutch child language is illustrated in (6).

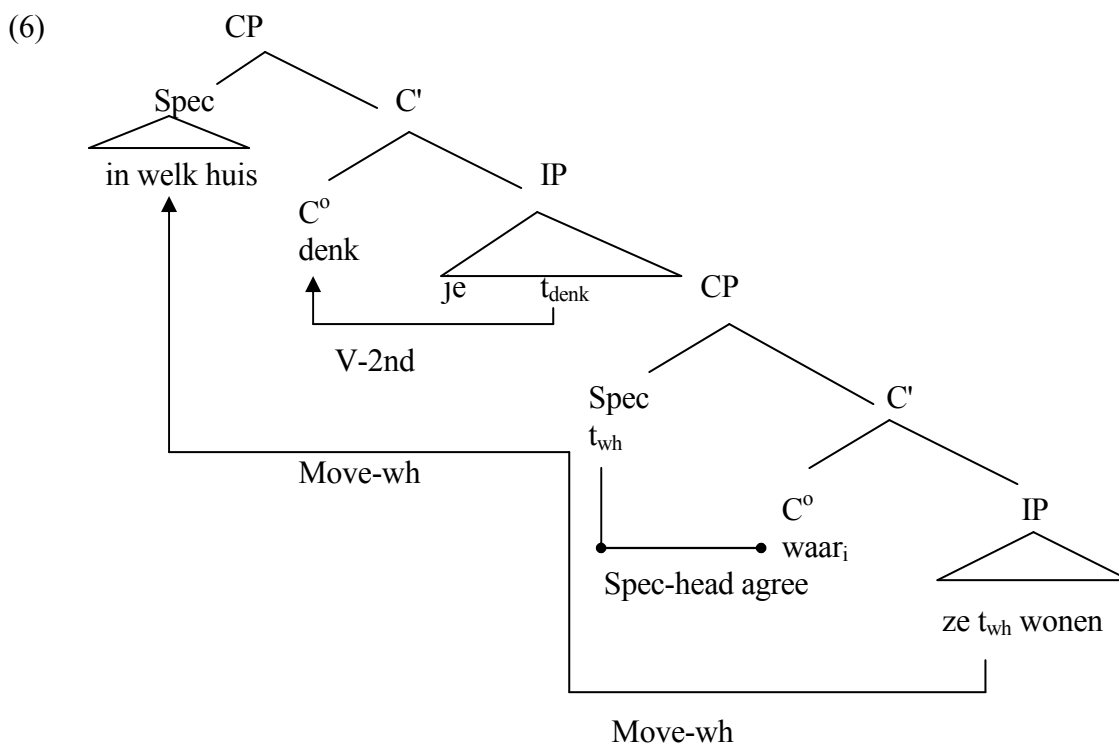

*Ad (2)c, analytical representation.* The PF representation in child language is more analytical than the PF representation in adult Dutch. The wh-agreement marks the transparency of the C<sup>0</sup> for long movements. As such it is more explicit about the LF of the construction. The analysis implies that wh-elements do not move in one long step.

## 2.2 Spell-out of hidden positions in the NEG-chain

Dutch child language often displays UG constructions with negative concord, as in (7).<sup>3</sup>

<sup>3</sup> The constructions with negative concord have been registered between the following ages. Laura: 2;4.21-5;5 / Sarah: 3;2-5;11. See for more Dutch child data also Kaper (1975:31f), Schaerlakens and Gillis (1987:154). The construction merits a more extensive treatment than the one we can offer here.

## PF/LF CONVERGENCE IN ACQUISITION

- (7) a. dat is *niet* apen *niet* (L. 2;7)  
       that is not apes not  
       b. Ik heb *niemand* *niet* gezien (S. 3;2)  
       I have nobody not seen

*Ad (2)a, ungrammaticality in target language.* The spell-out of negative concord is not acceptable in the (formal) target language. In standard adult Dutch the negation is only on the argument, as in (8).

- (8) a. dat zijn *geen* apen  
       that are not apes  
       b. ik heb *niemand* gezien  
       I have nobody seen

*Ad (2)b, availability in UG.* The negative concord construction in child grammar constitutes a potential PF representation. Negative concord appears in adult Afrikaans, Italian, Middle Dutch, Russian, Creole languages (Haegeman and Zanuttini 1991; Acquaviva 1994). Several remarks in the literature point out that there is a correspondence between wh-constructions and Neg-constructions. Both require the existence of a chain. The Neg/wh correspondence has been highlighted in Acquaviva (1994). We accept his analysis of Negation in the present paper. The Neg/wh correspondence concerns the scope assignment.

A first similarity is the scope of a negated or questioned indefinite. It may cross several c-commanding CP/IP boundaries, as in (9).

- (9) a. I do not<sub>i</sub> believe that [ she has seen anything<sub>i</sub> ]  
       b. What<sub>i</sub> do you believe that [ she has seen t<sub>i</sub> ]

A second similarity is the existence of scope markers. Languages may express the scope of a negation or question by means of a scope marking head, Neg<sup>o</sup> or Q<sup>o</sup> respectively. Finally, there is a third similarity. Depending on the type of language, the wh-marked or Neg-marked indefinite argument may be moved into the Specifier position associated with the scope marking head Q<sup>o</sup> or Neg<sup>o</sup>.

Acquaviva (1994:121) proposes that negation as well as questioning are based on the scope-marking heads Neg<sup>o</sup> and Q<sup>o</sup> in all languages. The spell-out of these heads as well as the overt movement of the indefinite argument into the specifier position near these heads follows from conditions on the PF realizations of the UG Neg-chain. Many languages, Dutch among them, require that the scope marking head remains empty if the related argument is marked <+wh> or <+Neg>.

By contrast, the chain between the scope marking head Neg<sup>o</sup> and the indefinite is systematically spelled out in Dutch child language, as in (10). This outcome was to be expected in our view on the LF transparency of child language in general.

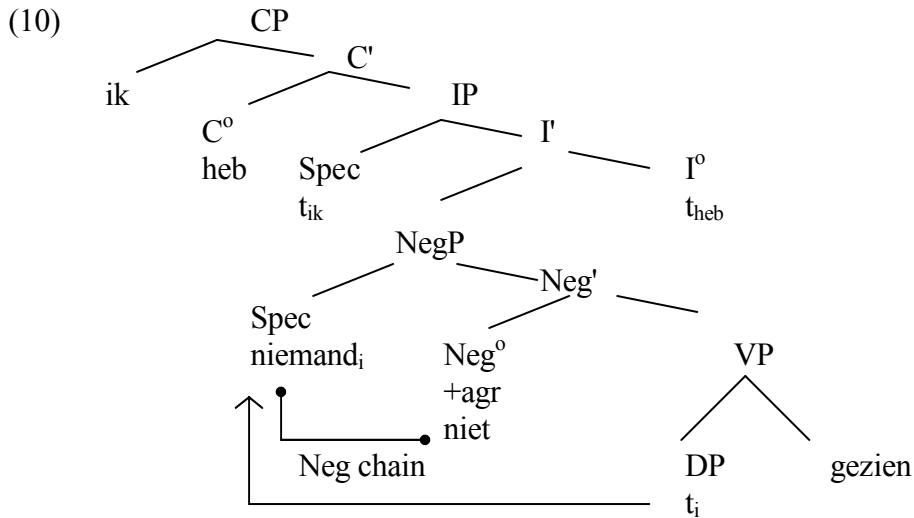

*Ad (2)c, analytical representation.* The PF representation in child language is more analytical than in adult language, since both members of the NEG-chain are spelled out.

### 2.3 Violation of the Left Branch Condition

In child language the Left Branch Condition (Ross 1967) may be violated, as in (11) (Hoekstra and Jordens 1994; Van Kampen 1994a,b).<sup>4</sup>

- (11)
- |    |                |                |                               |                     |         |          |
|----|----------------|----------------|-------------------------------|---------------------|---------|----------|
| a. | <i>welke</i>   | wil jij        | [ <i>t<sub>wh</sub></i>       | <i>liedje</i> ]     | zingen? | (S. 3;7) |
|    | which          | want           | you                           | song                | sing?   |          |
| b. | mag ik proeven | <i>hoe</i> het | [ <i>t<sub>wh</sub></i>       | <i>heet</i> ]       | is?     | (L. 4;3) |
|    | may I taste    | how            | it                            | hot                 | is?     |          |
| c. | wil jij        | <i>dit</i>     | nog[ <i>t<sub>focus</sub></i> | <i>stukje brood</i> | ]?      | (S. 5;5) |
|    | want you       | this           | still                         | peace of bread      |         |          |

Van Kampen (1994) proposed that in these sentences the D°/Deg°-head is raised into an A-bar head position, whereas the lexical restriction stays in situ. The wh- and focus-subextractions are attested with arguments in object-position only.

*Ad (2)a, ungrammaticality in target language.* These constructions do not appear in the adult input of the learning procedure. In adult Dutch left branch extractions are not tolerated.

- (12)
- |    |                                      |                                     |                             |         |
|----|--------------------------------------|-------------------------------------|-----------------------------|---------|
| a. | [ <i>welk liedje</i> ] <sub>DP</sub> | wil jij                             | <i>t<sub>DP</sub></i>       | zingen? |
|    | which song                           | want you                            |                             | sing?   |
| b. | mag ik proeven                       | [ <i>hoe heet</i> ] <sub>DegP</sub> | het <i>t<sub>DegP</sub></i> | is?     |
|    | may I taste                          | how hot                             | it                          | is?     |

<sup>4</sup> Left branch violations are registered between the following ages. Laura: 2;9-8;8.18 / Sarah: 3;7-5;5.27.

## PF/LF CONVERGENCE IN ACQUISITION

*Ad (2)b, availability in UG.* Nevertheless, child grammar makes use of a potential PF representation. The construction is found in the adult language of Czech, Latin, Polish, Russian, among others (Ross 1967:131; Corver 1990).

Polish wh-subextractions are also restricted to object positions, according to Corver (1990). We assume that the D<sup>0</sup> head of the object is properly governed by the verb and can be subextracted. Pied-piping of the X'<+N> complement may be due to a PF condition. The D<sup>0</sup>-N<sup>0</sup> agreement in phi-features may or may not require a PF adjacency. Adult grammars with a rich case system, like for instance Polish, allow such left branch violations. Grammars without overt case, like for instance Dutch, require strict adherence to Ross' Left Branch Condition. This implies a reinterpretation of the Left Branch Condition. What we have in mind is that D<sup>0</sup> morphology requires complement adjacency at PF. For example by means of a D<sup>0</sup> feature <+attributive> adjacency. In poorly inflected languages the <+attr> marking can only be deleted or spelled out under adjacency at PF. In highly inflected languages the morphological feature can be spelled out context freely by means of the phi-features of the extended projection (number, gender, case, definiteness, animacy, etc.). Corver (1990) derives the Left Branch Condition differently. See Van Kampen (1994) for a discussion.

The adjacency conditions of poor <+attr> morphology are acquired slowly. Let's suppose that, at least in child language, there is no <+attr> spell-out at all. This would allow the child to ignore the Left Branch Condition. The structure in (13) is an illustration of the negative value <-attr adjacency> in Dutch child language.

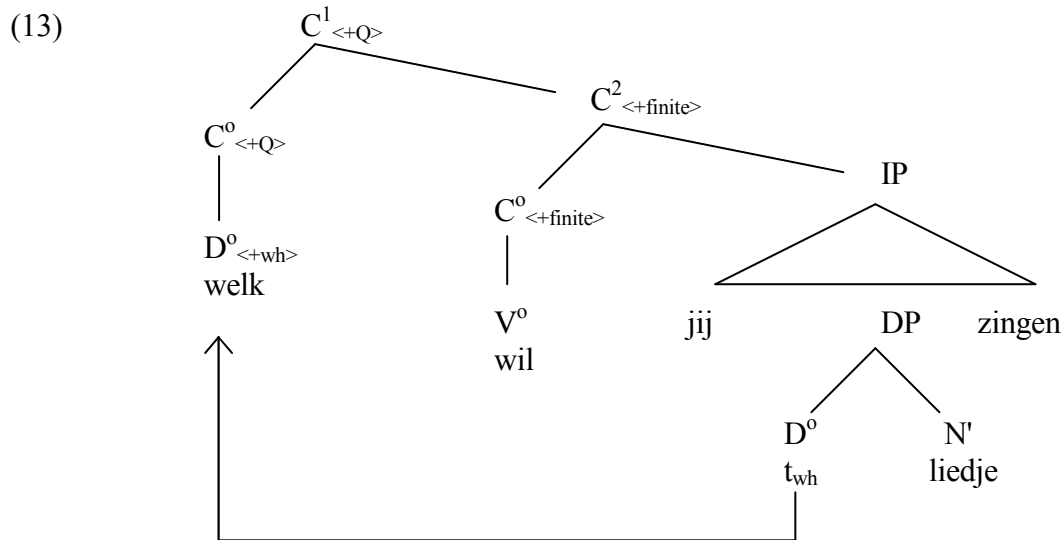

Empirical support for the present view on pied piping is found in Bresnan's subextractions in comparative constructions (Bresnan 1975).

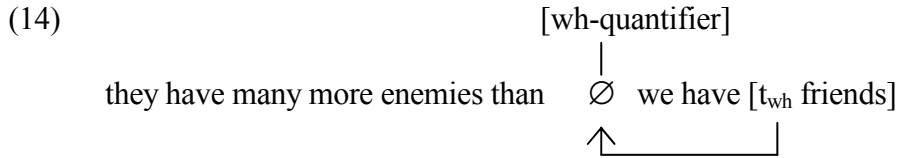

The crucial point is the obligatorily empty D<sup>0</sup> position in front of *friends*. Bresnan used this phenomenon as an argument against Chomsky (1977).

Chomsky (1977) had argued that comparatives like (15) follow from an underlying wh-movement.

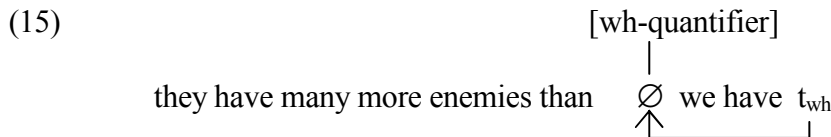

The relation between the comparative constant *than* and the empty position t<sub>wh</sub> is island sensitive. Island sensitivity of deletions might be explained by having a successive cyclic wh-movement first and a deletion in the target position *than*/C<sup>0</sup> later on. Therefore, comparative constructions should be derived by means of a wh-movement of the compared element. But, since the comparative construction demonstrates a stranding of the complement, *friends* in (14), Bresnan (1975) pointed out that Chomsky's wh-proposal for comparatives predicted the irrelevance of the LBC for wh-movement and therefore the grammaticality of (16) along with (14).

(16) \*which do we have t<sub>wh</sub> friends

The ungrammaticality of (15) cast a shadow on Chomsky's (1977) proposal to derive all island sensitivity from a generalized wh-movement. The present proposal of pied piping vindicates Chomsky's original proposal against Bresnan's objection. The sentence in (16) violates the PF adjacency requirement, whereas the timely deletion in C<sup>0</sup> of the relevant D<sup>0</sup> wh-features in (14) makes their greed for an adjacent complement vain. By consequence, the comparative sub-extractions are predicted to be grammatical in languages like English or Dutch, although these languages are sensitive to the Left Branch Condition.

*Ad (2)c, analytical representation.* The PF representation in child language is more analytical than in adult language, since the wh-head movement is a direct reflection of the LF representation. Stranding the lexical material in its argument position evades the need of its Reconstruction at LF.



## 2.4 Overgeneralization of P<sup>0</sup> stranding

P<sup>0</sup> stranding appears as a general option in child language. Next to movement of the full [P<sup>0</sup><+ wh>]<sub>PP</sub>, one finds many examples as the kind illustrated in (17).

- (17) a. weet je *wat* ik [*over t<sub>wh</sub>*] heb gedroomd? (S. 3;11)  
           know you what I about have dreamt?  
       c. ik weet *hoeveel* we [*t<sub>wh</sub> mee*] zijn (L. 6;10)  
           I know how many we with are

*Ad (2)a, ungrammaticality in target language.* Constructions like (16) do not appear in the input of the learning procedure. Standard adult Dutch restricts the P<sup>0</sup> stranding to cases where the P<sup>0</sup> complement is a <-animate> pronoun with a special morphological marking (*waar* ‘where’, *daar*, *er* ‘there’). For an analysis of this group see Van Kampen and Evers (1995).<sup>5</sup> The adult equivalents of (17) are in (18).

- (18) a. *waar* heb je [*t<sub>er</sub> over*] gedroomd?  
           where have you about dreamt?  
       b. [*waarover*]<sub>PP</sub> heb je *t<sub>PP</sub>* gedroomd?  
           where about have you dreamt?  
       c. ik weet [*met hoeveel*]<sub>PP</sub> we *t<sub>PP</sub>* zijn  
           I know with how many we are

*Ad (2)b, availability in UG.* P<sup>0</sup> stranding represents a potential PF representation. General P<sup>0</sup> stranding in (subcategorized) PP's is found e.g. in adult English. This is the common picture. The child's generalized P<sup>0</sup> stranding is ungrammatical in the target language. As a potential parameter setting it appears in other languages, e.g. English.

There is a disagreement about P<sup>0</sup> stranding between Van Riemsdijk (1978:4;276) and Stowell (1981:448). Van Riemsdijk claims that P<sup>0</sup> stranding is a marked phenomenon, whereas pied-piping is not. Stowell is unwilling to consider P<sup>0</sup> stranding a marked phenomenon. He suggests that P<sup>0</sup> stranding will be standard in languages with particles. Stowell's position tallies with Dutch child language. Particles are known in child language from the earliest two-word stage on and the children do apply P<sup>0</sup> stranding as a general option. In order to incorporate Stowell's suggestion in a parameter story, we propose the following.

Suppose there are two possibilities for P<sup>0</sup>. P<sup>0</sup> may be a head in an extended N<sup>0</sup>/D<sup>0</sup> projection. Let us provisionally indicate this as P<sup>0</sup> <+D>. P<sup>0</sup> may also be a head with a projection of its own. Let us indicate this as P<sup>0</sup> <-D>. This latter possibility is realized if P<sup>0</sup> appears as a particle. Particles are clearly P<sup>0</sup>'s, in phonological form and in semantic content. Moreover, they are understood quite early in child language as predicative elements. We assume now that the early presence of such particles will make ambiguous all prepositions

<sup>5</sup> P-stranding with non *er*-marked elements has been registered between the following ages. Laura: 3;1.14 - 8;2.20 / Sarah: 2;5 - 5;9.13 .

between a noun variant  $\langle +D \rangle$  and a predicative variant  $\langle -D \rangle$ . The noun variant, marked  $\langle +D \rangle$ , will block wh-movement of its complement. We may see this as a result of relativized minimality. Wh-movement is primarily movement of a  $D^0$  element  $\langle +WH \rangle$ . It will not cross a c-commanding  $P^0$  if this  $P^0$  is  $\langle +D \rangle$ . Therefore, wh-movement must pied-pipe the  $P^0 \langle +D \rangle$ . The predicative  $P^0 \langle -D \rangle$  will not block the wh-movement. Wh-movement will strand the  $P^0 \langle -D \rangle$  obligatorily, since by assumption  $P^0 \langle -D \rangle$  is not part of the extended N-projection. The obligatorily stranded  $P^0$  is a parallel to the  $V^0$ . If the object of the  $V^0$  is wh-moved, the  $V^0$  will never be pied piped by its wh-moving object, since it is not part of the  $\langle +wh \rangle$ -marked projection. The introduction of a  $P^0 \langle +D \rangle$  and a  $P^0 \langle -D \rangle$  in particle languages derives  $P^0$  stranding as a general option, as suggested by Stowell (1981: 448). Standard Dutch differs from informal Dutch and child language by an exclusive preference for the  $\langle +D \rangle$ . The negative option  $P^0 \langle -D \rangle$  in Dutch child language is illustrated in (19).

(19)

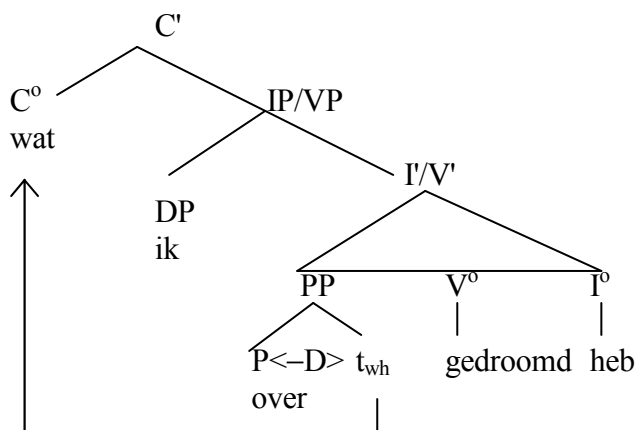

*Ad (2)c, analytical representation.* Arguably,  $P^0$  stranding fits a picture of reduced PF/LF discrepancy. The  $P^0$  characterizes the argument position, not the operator. Consequently, the  $P^0$  at LF has to be located in the argument position. Therefore, the wh-head movement that strands the  $P^0$  is a direct reflection of the LF representation. It evades Reconstruction of the preposition at LF.

## 2.5 Evasion of V-2nd by `do'-insertion

Constructions with grammatical tense-support, by means of a dummy verb *doen* `do' as in (20), represent a general possibility in child language.<sup>6</sup>

- (20) a. wat doe jij zeggen? (S. 3;4)  
 what do you say?

<sup>6</sup> Examples of *do*-insertion have been registered between the following ages. Laura: 4;6 - 8;1.1 / Sarah: 3;1.19 - 5;9.18. See for more Dutch child data Jordens (1990:1433f), Schaerlakens and Gillis (1987:141), Evers and Van Kampen (1995).

PF/LF CONVERGENCE IN ACQUISITION

- c. dat *doe* ik *spelen* (S. 5;9)  
 thatdo I play  
 (I am pretending that)

A grammatical verb is inserted in tense-position and the lexical verb stays in situ.

*Ad (2)a, ungrammaticality in target language.* *Do*-insertion is not acceptable in the (formal) target language. In standard Dutch the finite verb is moved into the second position (V-2nd), as in (21).

- (21) a. wat *zeg<sub>i</sub>* je *t<sub>i</sub>*?  
 what say you?  
 b. dat *speel<sub>i</sub>* ik *t<sub>i</sub>*  
 that play I

*Ad (2)b, availability in UG.* The *do*-insertion of child grammar makes use of a potential PF representation. Insertion of a dummy tense carrier is likely to be present in all Germanic languages. By contrast, adult input in Dutch does not allow *do*-insertion of tense as a free option. In general it applies I-to-C movement known as V-2nd, but there is an adult use of *do*-insertion as well. If the VP is empty, due to VP-ellipsis or VP-preposing, *do*-insertion may appear in adult Dutch as example (22) shows.

- (22) de roos treffen *doet* hij zelden  
 the mark hit does he seldom  
 (hit the mark he seldom does)

Suppose we indicate this use of auxiliary verbs as <+pro(nominal)>. A <pro>verb may be used only if there is a VP-complement and the VP-complement is empty. Evers and Van Kampen (1995) assume that the adult restriction is due to a setting of a PF parameter <+ pro verb> on the I<sup>0</sup> element *doe* 'do'. The structure in (23) illustrates the negative option, that is parameter setting <- pro verb>, in child language. In that case the VP-complement may be lexical.

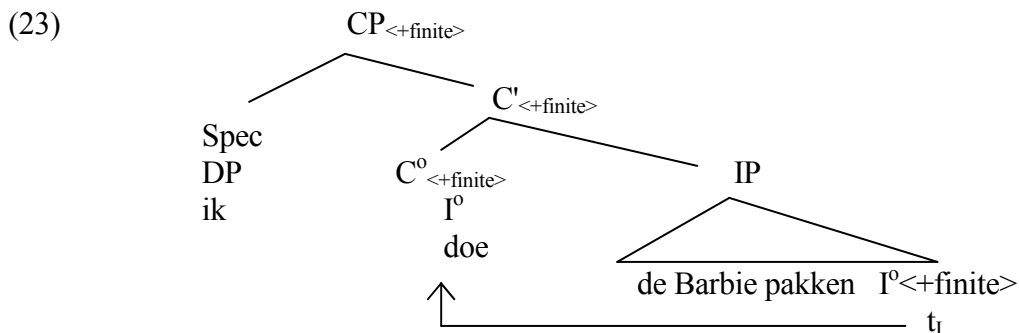

*Ad (2)c, analytical representation.* The lack of the <+ pro> restriction in child language allows PF representations that are more analytical than their counterparts in adult language. The *do*-

insertion constructions in child language are a direct spell-out of the LF chain tense-lexical verb. When the lexical verb is moved to the tense-position a less analytical structure is created. The finite verb represents a tense function, as well as an argument licensing function. The movement of the lexical verb into functional positions gives up a full spell-out of the tense-V chain. It will require a Reconstruction of lexical information at LF. Direct insertion of *do* into functional positions ( $I^0/C^0$ ) reduces the PF/LF discrepancy. I-to-C (V-2nd) constitutes a step towards a more compact information packaging and not an operation towards an LF representation. See Arnold (1995) for a diachronic analyses of *do*-insertion as a first resort in English.

### 3. Five parameters on PF/LF discrepancy

The analysis of the five constructions has revealed the potential relevance of a PF parameter. The separate parameters are formulated in (24) and the generalization is given in (25).

- (24)
- |    |   |                                   |
|----|---|-----------------------------------|
| a. | $\langle \pm \text{wh agr} \rangle_{C^0}$                 | learning task for Dutch: set on – |
| b. | $\langle \pm \text{NEG agr} \rangle_{\text{Nego}}$        | learning task for Dutch: set on – |
| c. | $\langle \pm \text{attr adjacency} \rangle_{D^0}$         | learning task for Dutch: set on + |
| d. | $\langle \pm D \rangle_{P^0}$                             | learning task for Dutch: set on + |
| e. | $\langle \pm \text{pro verb} \rangle_{I^0 \text{ tense}}$ | learning task for Dutch: set on + |

- (25) *PF parameter on  $X^0$  morphology*  
 $[\langle \pm F \rangle]_{X^0}$  learning task: set the target value

The correct values of the parameters were forced almost immediately by the input evidence, but only as options. Nevertheless, the alternative values remained in use as general options.

The resolution of this paradox has already been indicated in (3)a. The choices made by the LAD strategy serve the same purpose: a temporary reduction of the PF/LF discrepancy. The WH-, NEG- and TENSE-chains remain unchanged at LF. Later on, both the omission and the addition of the PF conditions in the adult language increase the PF/LF discrepancy. This leads us to further proposals in (26).

- (26) *Theoretical perspectives*
- The language learner does indeed find ways to a temporarily reduced PF/LF discrepancy.
  - The language learner moves from a superset language, with an additional option, to a subset language, without the additional option.
  - The LAD's parameter setting is not a matter of cognitive 'switches', but rather one of preferred options that fade out slowly. The target is known and serves as a point of orientation.

The implications of the proposals in (26) will be discussed below.

#### 4. Theoretical perspectives

##### 4.1 Reconstruction

The mapping between the language specific PF and the universal LF representation measures the PF/LF discrepancy. The Raisings from LF to PF come in two kinds,  $X^0$  raising (head-to-head movement: V-movement in (21)) and  $X'$  raising (pied piping: in (12) and (18)). The Raisings are triggered by morphological greed of the  $X^0$  or by a PF adjacency requirement of the  $X'$ . Both triggers seem to serve the same purpose at PF. They arrange a more local relation between lexical head and functional head. Head-to head ( $X^0$ ) movement merges a lexical and a functional head that belong to the same extended projection. A lexical and functional head merge into a single word unit. A functional  $\langle +wh \rangle$  head that moves into the position of a scope assigning element, may pied pipe the  $X'$  of the extended projection it belongs to. This preserves the phrasal bond between functional and lexical projections.

The two Raisings, head movement in (21) and pied-piping in (12) and (18), have two Reconstruction movements as counterparts.<sup>7</sup> These reconstruction movements move all non-functional material back into its LF positions. There is  $X^0$  lowering as a counterpart of I-to-C raising and  $X'$  reversion, as a counterpart of pied-piping. The Reconstructions lower lexical material and in that way they split phrases involved in theta assignment and scope assignment. The scope-assigning head of the chain must abstract away from the associated lexical information. Likewise the theta-assigning foot of the chain must abstract away from the scope-assigning elements.

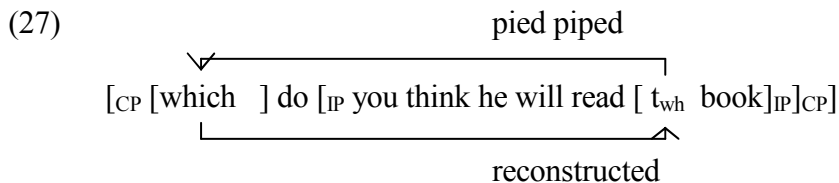

That is, only lexical categories assign a theta-role (and chains do not) and only functional categories have a c-commanding scope (and lexical material has not). These assumptions about LF deviate from the assumptions in Chomsky (1992), although less so from his recent (1995) assumptions. In our view there can never be Raising at LF, nor would morphological constructs function as heads of LF chains. LF looks now more like the former Deep Structure: all lexical items have to be in argument positions (cf. Hornstein and Weinberg 1990).

The constructions in (1)c/d/e (sections 2.3/2.4/2.5) fit now into the picture. Child language avoids Raising of  $X^0$  (V-movement in (1)e) and of  $X'$  (pied piping in (1)c,d). It avoids thereby

<sup>7</sup> Reconstruction has usually been advanced on empirical grounds. Reconstruction within the present context is a principle rather than a fact saving device. See for a principled conception of Reconstruction also Williams (1986).

Reconstruction and maintains a reduced PF/LF discrepancy. The constructions in (1)a,b reduce PF/LF discrepancy in a somewhat different way. They reflect LF chains in PF elements.

#### 4.2 Parameter setting: Climbing towards High LF Credit

The intentions of the original parameter setting proposals were that parameter setting should be: a. fast and (rather) without mistakes and b. developing a subset into a superset language. The main difficulties of this view are that language development shows long periods of optionality in which a superset develops into a subset. The development towards the more restricted target language contradicts the Subset Principle, which holds that the acquisition procedure should start, rather than end, with a subset.

The reduction to the eventual subset makes sense in terms of a growing ability to handle PF/LF discrepancy. The adult forms seem to make more use of 'hidden operations'. Child language by contrast saves on hidden LF operations. If the space for hidden LF operations is indicated as LF credit, one may say that child language tries to operate on low LF credit and formulate it as in (28).

- (28) a. Adult language is more free in hidden LF operations.  
It operates on high LF credit.  
b. Child language economizes on hidden LF operations.  
It operates on low LF credit

The positive values  $\langle + \text{wh agr} \rangle_{\text{Co}}$ ,  $\langle + \text{NEG agr} \rangle_{\text{Nego}}$  in (23)a/b, and the negative values  $\langle -\text{attr adj} \rangle_{\text{Do}}$ ,  $\langle - \text{D} \rangle_{\text{Po}}$ ,  $\langle - \text{pro verb} \rangle_{\text{Io}}$  in (24)c/d/e constitute choices of a subgrammar that economizes on hidden LF operations.

This idea of LF credit seems to us to already have been expressed by Lebeaux (1988: 173f,180). Learning a language is in Lebeaux' view not so much comparable to the setting of a parameter-switch, but rather to the climbing of a hill. The child has at his disposal the default as well as the more marked value a parameter. The choice between the two is *more a question of performance than of competence*. If the language learner cannot make it to the top of the hill (high LF credit), he falls back into a less costly 'hollow', that is an option that requires less LF credit.

The hill-top metaphor and its implications for the theory of language acquisition can be extended to all syntactic parameters if we make certain assumptions. Suppose that all syntactic parameters are there to measure a PF/LF discrepancy. Their binary nature may then follow from the PF/LF distinction. One parameter value invariably has the effect to preserve the LF configuration into its PF realization. This value would always be the default. It is easily accessible and may appear spontaneously during the acquisition period. The other parameter value has a language specific PF effect. It brings about a more dense information packaging and, although it may have been perceived by the language learner quite early, it will not be fully mastered without a considerable period of exercise. During that period the UG option in the parameter will appear as an alternative within the child grammar, contrary to the assertions of the Subset Principle.

## PF/LF CONVERGENCE IN ACQUISITION

### References

- Acquaviva, P. (1994) 'The Representation of Operator-Variable Dependencies in Sentential Negation', in: *Studia Linguistica* 48(2), 91-132.
- Arnold, M.D. (1995) *Case, Periphrastic 'Do', and the Loss of Verb Movement in English*, PhD. dissertation University of Maryland.
- Bresnan, J.W. (1975) 'Comparative Deletion and Constraints on Transformations', in: *Linguistic Analysis* 1, 25-74.
- Chomsky, N. (1977) 'On WH-movement', in: P. Culicover, T. Wasow, and A. Ackema (eds.) *Formal Syntax*, 71-133, New York: Academic press.
- Chomsky, N. (1992) 'A Minimalist Program for Linguistic Theory', *MIT Occasional Papers in Linguistics* 1.
- Chomsky, N. (1995) 'Categories and Transformations', ms. MIT, Cambridge Massachusetts.
- Corver, N.F.M. (1990) *The Syntax of Left Branch Extractions*, PhD dissertation Tilburg University.
- Evers, A. and N.J. van Kampen (1995) 'Do-insertion and LF in Child Language', in: J. Don, B. Schouten, W. Zonneveld *OTS Yearbook 1994*, 24-41, Utrecht University.
- Haegeman, L. and R. Zanuttini (1991) 'Negative heads and the Neg Criterion', in: *The Linguistic Review* 8, 233-251.
- Hoekstra, T. and P. Jordens (1994) 'From Adjunct to Head', in: T. Hoekstra and B.D. Schwartz (eds.) *Language Acquisition Studies in Generative grammar*, 119-149, Amsterdam: John Benjamins.
- Hornstein and Weinberg (1990) 'The Necessity of LF', in: *The Linguistic Review* 7, 129-167.
- Hyams (1986) *Language Acquisition and the Theory of Parameters*, Dordrecht: D. Reidel.
- Kampen, N.J. van (1994a) The Learnability of the Left Branch Condition, in: R. Bok-Bennema and C. Cremers (eds.), *Linguistics in the Netherlands 1994*, 83-94. Amsterdam: John Benjamins.
- Kampen, N.J. van (1994b) 'Subextraction of Operators: Evidence from Child Language', ms. Utrecht University.
- Kampen, N.J. van and A. Evers (1995a) 'How Greedy is the Child? Long Distance Movement in Small Steps', in: *Amsterdam Series in Child Language Development* 3, 91-108.
- Kampen, N.J. van and A. Evers (1995b) LF Relevance in Language Acquisition', in: *Amsterdam Series in Child Language Development* 4, 1-31.
- Kaper, W. (1975) 'Negatie in de Kindertaal', in: *Forum der Letteren* 16-1, 18-44.
- Klein, S.M. (1982) *Syntactic Theory and the Developing Grammar: Reestablishing the Relationship between Linguistic Theory and Data from Language Acquisition*, PhD. dissertation UCLA.
- Lebeaux, D. (1988) *Language Acquisition and the Form of Grammar*, PhD. dissertation University of Massachusetts.
- Lightfoot, D.W. (1979) *Principles of Diachronic Syntax*, Cambridge: Cambridge University Press.
- MacDaniel, D. (1986) *Conditions on WH-chains*, PhD. dissertation City University of New York.

JACQUELINE VAN KAMPEN

- Riemsdijk, H. van (1978) *A Case Study in Syntactic Markedness. The Binding Nature of Prepositional Phrases*, PhD. diss. University of Amsterdam.
- Roeper, T. (1991) 'How a marked Parameter is Chosen: Adverbs and *Do*-insertion in The IP of Child Grammar', in: T. L. Maxfield and B. Plunkett, eds., *UMOP Special edition: Paper in the Acquisition of WH*, 176-202.
- Ross, J.R. (1967) Constraints on Variables in Syntax. PhD. dissertation MIT, Cambridge Massachusetts.
- Schaerlakens, A.M. and S. Gillis (1987) *De Taalontwikkeling van het Kind, een Oriëntatie in het Nederlandstalig Onderzoek*, Groningen: Wolters-Noordhoff.
- Stowell, T. (1981) *Origins of Phrase Structure*, PhD. dissertation MIT, Cambridge Massachusetts.
- Thornton, R. and S. Crain (1994) Successful Cyclic Movement, in: T. Hoekstra and B.D. Schwartz *Language Acquisition Studies in Generative Grammar*, 215-252, Amsterdam: John Benjamins Publishing Company.
- Williams, E. (1986) 'A Reassignment of the Functions of LF', in: *Linguistic Inquiry* 17-2, 265-299.