



Research paper

Evaluation of wood pellet handling in import terminals

I. Dafnomilis^{a,*}, G. Lodewijks^b, M. Junginger^c, D.L. Schott^a^a Maritime and Transport Technology, Delft University of Technology, Mekelweg 2, 2628CD, Delft, The Netherlands^b UNSW Aviation, The University of New South Wales, Sydney NSW, 2052, Sydney, Australia^c Copernicus Institute of Sustainable Development, Utrecht University, Heidelberglaan 2, 3584CS, Utrecht, The Netherlands

ARTICLE INFO

Keywords:

Biomass
Wood pellets
Wood pellet handling
Wood pellet storage
Import terminal

ABSTRACT

Wood pellet imports are expected to increase in the European Union and Southeast Asia by 2030, considering pellets are the main feedstock used for co-firing in power plants throughout these regions. Due to the material's physical and biological properties, the equipment at an import terminal need to be different than what is used for other bulk material. Thus, most of the common problems associated with handling can be avoided. Dust emission and explosions, degradation in storage, self-heating and ignition are important criteria when designing a wood pellet port terminal, and can greatly affect associated logistics. Despite some availability of data concerning the handling of pellets, there is a lack of insight into the equipment and operations of actual handling facilities. A detailed literature research was performed in order to ascertain the level of the scientific background on the subject. Subsequently, visits in pellet facilities in the Netherlands and in-depth interviews with representatives were conducted and serve as a means of gaining an overview of current industry practices and equipment used for the handling of wood pellets. The main objective of this work is to evaluate the state-of-the-art in wood pellet handling in import terminals. This way, future bottlenecks can be identified and actions needed to overcome them can be determined. The analysis performed shows that while wood pellet terminals might be able to cope with the low amounts being traded currently, a reexamination and redesign of terminal facilities to accommodate the increased volumes will probably be required by 2030.

1. Introduction

Biomass used for energy purposes (bioenergy) is expected to increase in final energy consumption in all the European Union Member States (MS). In 2014, bioenergy consumed in European Union (EU) amounted to 61% of the total renewable energy consumption or 4416 PJ, and 10% of the gross final energy consumption. Use of biomass was concentrated mainly in the heating sector (88% of total renewable heating), but with significant contributions to electricity production and transport fuels [1]. Although this share is expected to decrease by 2020 to a total of 57% [2], due to the development of other renewable sources such as wind and photovoltaics (PV), the actual amount of biomass for heating, electricity and transport is expected to rise to 5860 PJ [1].

The largest part of EU biomass supply is and will be based on domestic sources; currently, 4% of the total biomass used for energy purposes is imported. However by 2030, this amount could substantially increase, taking into account potential supply gaps, especially in the industrial sector (electricity production, closing down of coal power plants) [3,4].

Specifically, wood pellet use in the EU is expected to grow in sectors such as co-firing in coal power plants and residential heating in the short-term future, and possibly in the form of high quality industrial heat in the long-term future [4]. The majority of the wood pellets consumed will be imported, as many of the EU members lack the industrial tradition of wood processing on the one hand, and import of wood pellets from overseas seems to be more economically efficient than road transportation, even from neighboring countries [5]. In the Netherlands, the use of wood pellets in coal-fired power plants will be ramped up to approximately 25 PJ by 2020 [6]. This corresponds to approximately 3.5 Mt of imports, since the country has been relying on them in order to reach the renewable energy target for electricity production [7], and is expected to rely on them for the foreseeable future. Concurrently, Belgium consumed more than 1.5 Mt of wood pellets in 2015, almost exclusively imported. Similarly, Denmark consumed 2.6 Mt of imported wood pellets in 2015 [8]. In total, the 3 countries are expected to consume more than 11 Mt by 2025 [9]. Accordingly, the bulk port terminals in the Amsterdam-Rotterdam-Antwerp (ARA) region will have to accommodate the increased flows of wood pellets.

* Corresponding author. Mekelweg 2, 2628 CD, Delft, The Netherlands.

E-mail address: I.Dafnomilis@tudelft.nl (I. Dafnomilis).

List of acronyms

EU	European Union
MS	Member State
PV	Photovoltaic
ARA	Amsterdam-Rotterdam-Antwerp region
RPS	Renewable Portfolio Standard
ISO	International Organization for Standardisation
DEM	Discreet Element Method
CSU	Continuous Ship Unloader
ATEX	Atmosphères Explosibles (Explosive Atmospheres)
RFID	Radio-frequency Identification
UN	United Nations
OECD	Organization for Economic Co-operation and

Development
CIF Cost, Insurance and Freight

Measurement units

J	Joule
t	tonnes
m	metre
kg	kilogram
m ³	cubic metre
°	degree angle
K	degrees Kelvin
s	second

At the same time, Japan and South Korea are set to become two of the largest wood pellet consumers in the world. Japan is looking to shift from a dependency on fossil fuels to renewable energy sources, and aims for biomass to comprise 20% of its renewables generation by 2030 [10]. The Japanese government recently approved regulations that allow major utility companies to benefit from the national feed-in-tariff. Wood pellet imports to Japan reflecting this policy change are expected to start in 2018 [8]. Canada is currently Japan's biggest source of wood pellets, supplying approximately 63% of Japan's imports in 2015 [11]. Similarly, South Korea aims to increase its wood pellet use through the Renewable Portfolio Standard (RPS) [12]. Having Vietnam as a primary supplier of biomass, South Korea could reach more than 8 Mt of wood pellet demand by 2025 [9]. Combined, these two countries could require more than 17 Mt of wood pellets by 2025, most of which will need to be covered by imports [11,13]. Overall, Asia is expected to provide one of the largest future growth opportunities in the medium-to long-term, leading to similar challenges for port facilities as in the EU.

Wood pellets are regarded as a bulk material, as they are mostly transported in large quantities. However, compared to traditional dry bulk materials, such as coal, grain and iron ore, wood pellets have other unique demands for handling, transport and storage, regarding for example prevention of degradation and moisture uptake [14]. Use of unsuitable equipment or careless treatment can damage the product or constitute major health and safety hazards. This constitutes the main issue with wood pellet terminal facilities: in order to optimize the handling procedures, the equipment and techniques at the respective terminals need to cope with the materials' specific properties. This is only realized to a limited extent at the moment; since the volumes currently being moved in the EU are low, they do not necessitate investments in specialized infrastructure.

The notable exception to this is the UK, where utility company Drax consumed 50% of the 2016 global industrial pellet demand of 13.6 Mt [15]. Drax is serviced by four ports, where dedicated biomass equipment and infrastructure is used to handle the incoming wood pellets, mainly from the Southeast US [16,17]. However, this required years of development of an expansive, specialized freight and logistics infrastructure dedicated to the import, storage and delivery of wood pellets (such as their high volume rail wagons [18]), and more than 284 million euros of investments (250 million pounds¹) [19]. Drax and the UK situation in relation to wood pellets represent an extreme end of the spectrum of pellet imports and it is not representative of the EU or Asian import terminal situation. While some terminals may come close to that range, especially if they function as a hub import terminal like stated in the following paragraph, achieving the scale of Drax's facilities is not going to manifest for the short to medium term future. However, the lessons to be learned by the UK's experience when handling wood

pellets can support import terminals around the world in decision making regarding biomass infrastructure setup and investments.

As an example, du Mez [20] states that the Port of Rotterdam aims to handle 8–10 Mt of wood pellets by 2020, and as such assume a hub role for biomass imports to the whole of Northwestern Europe [21]. This could have a range of implications for the receiving bulk terminals; existing infrastructure might have to be adjusted in the short term, while larger scale and elaborate infrastructure will be required in the long term future. Extended periods of development will be needed for most of these actions. Generally, even minor changes in a port terminals' design and operations require considerable investments in numerous elements of its setup. It is therefore crucial to have a comprehensive understanding of wood pellet terminal equipment setup and operations before any substantial commitments are made.

Despite numerous technical reports offering detailed advice on handling and storage of solid biomass in general [22–24], there is little information to be found in scientific literature considering a state-of-the-art approach in a real-world industrial setting. Several researchers have investigated different aspects of the subject: Rossner et al. [25] have researched the CO monitoring of small scale wood pellet storage for residential or small building use, and Proskurina et al. [26] looked into the bulk handling of wood pellets in export and import ports, for which the authors state that specialized equipment is required. The mechanical degradation of wood pellets during indoor and outdoor storage was examined by Graham et al. [27], albeit on a small scale. Graham et al. [28] also performed research on the mechanical properties of wood pellets in a laboratory environment. The most comprehensive and recent account of wood pellet handling and storage comes from Bradley and Carbo et al. [29,30], offering advice on selecting equipment when dealing with pellets, considerations when setting up a project, and future trends. Ilic et al. [31] provide the most recent and complete aggregation of key design parameters for solid biofuels in general, as well as suggestions on how to approach biomass handling systems design. Thus, research so far has examined different aspects of the wood pellet handling and storage infrastructure. However, the conclusions are either based on too small a scale, or they come in the form of general rules of thumb for design and use of equipment and methods. As such, most of the up-to-date scientific literature lacks a perspective of actual large scale, bulk pellet handling. Consequently, informed decisions regarding import terminal developments might be lacking. An in-depth analysis and assessment of receiving terminals has not been performed so far in a scientific article.

The main objective of this article is to assess the state-of-the-art in wood pellet handling in import terminals. After a comprehensive understanding of the current status in the particular research field is gained, the goal of providing advice on import terminal design changes is also explored. Potential future bottlenecks that might hinder wood pellet handling in import terminals are identified and suggestions to overcome these hurdles are provided.

¹ Based on the exchange rate of 1 GBP = 1.13497 EUR on December 5th 2017.

2. Materials and methods

2.1. Research approach

As a first step, an extensive literature review in wood pellet handling and storage issues was conducted. The aim was to comprehend the state-of-the-art and the limitations of the subject. Initially, the technical characteristics of wood pellets and how they relate to their handling aspects were researched. The most common issues that arise when handling or storing pellets are also examined and presented in Section 2.2. Consequently, dedicated equipment or measures to most effectively handle wood pellets in different handling chain steps are discussed in Section 2.3.

In continuity, due to the access the authors possessed to the biggest and most experienced bulk terminal operators in the Port of Rotterdam, as well as other industrial stakeholders related to wood pellet transport and use, the actual industrial condition of wood pellet handling in import terminals was examined. To do so, the authors participated in key planning meetings and conducted interviews with relevant to the subject employees of the wood pellet industry in the Netherlands. This provided a unique opportunity to gain a detailed account of first hand industrial conditions of wood pellet handling. Specifically, stevedoring companies and terminal operators that handle, among other products, pellets in the Port of Rotterdam, advisors on dry bulk cargo from the Port of Rotterdam Authority, equipment manufacturing and storage infrastructure companies were interviewed. The interviewees occupy several different positions within their respective companies and were contacted with the scope-limited agenda of providing information strictly related to wood pellet handling, based on their expertise and experience. Apart from these interviews, personal visits to the facilities were performed by the authors, techniques and equipment of the industrial entities engaged in pellet handling and storage were investigated and are presented in this article. The results of this part of the research are presented in Section 3.

The Port of Rotterdam is the busiest port in Europe and the 6th busiest in the world. The basic principles of wood pellet transportation in the Port of Rotterdam are representative of mix-product bulk ports worldwide and are applicable to other dry bulk ports [21,26,32–37]. The range and typology of facilities and equipment mirrors most of the small-to medium-sized bulk terminals. Through years of experience the terminal operators have settled in the few terminal setups that favor the handling of the most commonly traded materials, that include all types of hinterland transportation modalities - truck, rail and barge inland transportation. As such, the information gained can be used as a focal point to extract useful conclusions from, concerning wood pellet port terminal operations in general. The bulk terminals examined for the purposes of this work are not dedicated pellet terminals, since the incoming throughputs do not yet justify such investments. They are all mix-product bulk cargo terminals, i.e. they handle coal, iron ore, gypsum, grain and other bulk materials. While some equipment in place is suitable for pellet handling as well, terminals have already had to adjust some of their infrastructure and techniques. A significant increase of throughput of a new material, such as wood pellets, that requires different equipment and techniques than the ones used so far, will also require similar future applications between all pellet bulk terminals. Detailed information regarding the examined terminals at the Port of Rotterdam can be found in Section 3.

2.2. Technical characteristics of wood pellets and interaction with equipment

Wu et al. and Towler et al. [38,39], studied various decisive physical material properties of wood pellets in comparison to coal, as well as the characteristics of the material's interaction with mechanical equipment, presented in Table 1.

The similarity between most of the physical properties of coal and

wood pellets means that the fundamental design of equipment and infrastructure between the two bulk material could remain the same. However, the equipment in charge of handling wood pellets needs to be able to handle a wider range of flow properties due to the range of the physical properties values [39]. The relatively high bulk density and calorific value make wood pellets one of the most preferable solid biofuels, yet handling and storing wood pellets requires multiple units of equipment with larger volumetric capacities compared to coal [40]. Hancock et al. [13] state that the design of equipment for bulk material handling operations must be closely linked to the specific physical, mechanical and material interacting properties of the material.

Having knowledge of what kind of forces have an impact on feed-stock degradation can aid in choosing or designing equipment and methods in order to reduce those effects, or adjust existing facilities in order to better facilitate pellet handling. However, quality certification and standardisation of wood pellets is very fragmented, and there are many different national wood pellet-related standards [41]. Duca et al. [42] presented wood pellet standards used in Europe in the period 2006–2012. Currently, the International Organization for Standardisation (ISO) [41] is preparing almost 60 standards for all types of solid biofuels, including wood pellets, wood chips, wood briquettes as well as other types of thermally treated and densified biomass fuels. Nevertheless, current solid biomass experimental testing per ISO standards can be inconclusive as to whether it actually simulates real industrial scale handling conditions [43,44]. Schott and Mahajan [45,46], have performed Discrete Element Method (DEM) simulations of wood pellet behavior and have concluded that the current tumbling can testing cannot be considered as representative for realistic handling conditions for filling and discharging silos [45], or moving the material through transfer chutes [46]. Whittaker and Shield [47] also states that there is no standard protocol for drop tests for pellets, even though pellets are handled and dropped at least between eight to ten times between production and unloading at the final destination.

The main issue when handling wood pellets is the degradation and breakage of the material. Mechanical forces during transshipment, conveying and loading or unloading of vessels can cause particle degradation of the pellets, leading to fines and dust generation [22,48]. Wood pellet fines are specified as particles generated during wood pellet production, handling and storage that are smaller than the specified size of 3.15 mm, but not small enough to be classified as dust particles (100 μm) [49]. These dry pellet particles have a low density and high drag coefficient and can easily become airborne. Airborne particles can pose a significant health risk to personnel that come in contact with them, causing irritation of the lungs, nasal and respiratory system, allergic reactions and severe illnesses when exposed for a prolonged period of time [22].

Dust explosions are the second major risk linked to wood pellet handling. Dust particles of combustible materials mixed with air will burn with an intensity and speed increased with decreasing particle size [23]. Ignition of pellet dust can occur due to electrostatic discharges, high friction temperatures or hot surfaces at any point in the handling

Table 1
Physical properties of wood pellets compared to bituminous coal [38,39].

Material	Bituminous coal	Wood pellets
Size [mm]	–	6, 8, 12 (\emptyset)
Particle density [$\text{kg}\cdot\text{m}^{-3}$]	1200–1800	1200–1900
Bulk density [$\text{kg}\cdot\text{m}^{-3}$]	720–880	500–650
Net calorific value [$\text{GJ}\cdot\text{t}^{-1}$]	27	16–18
Moisture content [%]	< 20	8–11
Internal friction angle [$^{\circ}$]	–	33–43
Effective internal friction angle [$^{\circ}$]	55	39–45
Angle of repose [$^{\circ}$]	35–45	37–41
Breakage	N/A	Easy to break
Wall friction angle [$^{\circ}$]	–	9–35

chain. The required ignition energy can be very small and, after ignition, the combustion rate of a dust cloud is usually extremely fast, resulting in a dust explosion and possible fatal damage [23,50]. Dust explosions can propagate at a quick pace in completely enclosed spaces [51].

Other problems when dealing with large quantities of wood pellets can be self-heating and ignition, oxygen depletion, off-gas formation and biological hazards, which is directly related to the length of storage periods [24,52]. According to Röder et al. [53], wood pellet emissions during storage are also essential in properly accounting for the greenhouse gas emissions of the whole wood pellet supply chain. As can be deduced, all of the above do not only constitute a potential personnel threat, but also a significant professional and financial threat to the facilities that handle and store pellets; storage fires are quite common, even in regulated facilities, due to the unpredictability and parameters that affect the material self-ignition [22,54].

2.3. Wood pellet port equipment and procedures

The inherent problems with wood pellets, as well as the problems that arise during handling and storage, can be minimized with improvements to equipment design. Using specialized equipment or techniques specifically suited for the product, additionally to common handling methods and equipment, is a solution. This section presents a summary of ways to prevent problems and risks, as they appear in relevant technical reports or biomass related studies. Apart from general advice, the pellet handling procedures are subdivided into four distinct functions of solid bulk handling: transshipment (loading is considered as transshipment), transportation, storage and transfer (Fig. 1). Specific advice for each handling function can be found in the respective subsections.

Dust formation and dust explosions can be prevented either through reduction of the physical damage inflicted on the pellets during handling, or via dust containment and prevention of explosions. Handling and transport of wood pellets should be as gentle as possible, as the degree of degradation of pellets increases with the number of handling steps. Conveying distances and speeds should be kept to a minimum, and transfer points and large drops should be avoided as they increase the fine content. Getting the pellet trajectories right at transfer points, i.e. minimizing impact points and impact force, also helps to reduce the dust emissions. Handling and storage under enclosed buildings and conveyors is also suggested in order to avoid intake of moisture [55].

Stelte, Khan and the Nordic Innovation Centre [22,23,54] offer a detailed account on key features to deal with when handling wood pellets. In general the following should be observed: avoid unnecessary dust formation, secure sufficient ventilation, remove potential ignition sources and keep the premises clean.

Obernberger and Thek [56] offer general recommendations in order to avoid self-heating and ignition of pellet feedstocks. The distribution temperature within the stored material is the most important measure to take. If high temperatures (> 323 K) are detected, appropriate measures need to be taken. These usually include removing part of the material from the heap, spreading out the material over a larger area or recirculating it in the chain to facilitate cooling [23].

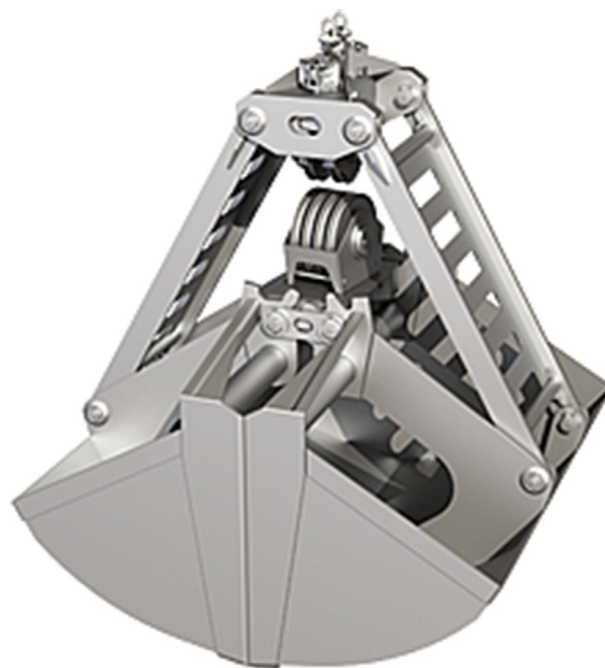

Fig. 2. Generic closed clam-shell grab design (Image courtesy of Nemag BV).

In order to address oxygen depletion, off-gas formation and biological hazards, emphasis should primarily be given to equipping enclosed storage areas with CO and CO₂ detectors, removing air pollution through ventilation, exhaust ventilation, curtains, walls, fine water sprays, closed sections and remote control. The gas composition must be analysed before the personnel enters the facility [48].

2.3.1. Transshipment

The first step when handling the wood pellets at a port terminal is to transship the material from the incoming vessel, which can be a ship, barge, truck or train. This can be done via multiple options: grabs, vertical conveyors, pneumatic systems, bucket elevators or self-unloaders.

When using a grab to unload the pellets, the focal point is the reduction of pellet degradation. According to Corbeau [59] from the grab manufacturing company Nemag, by experience, the closed clam-shell grab design (Fig. 2) reduces dust emission and breakage by 50% when used instead of pneumatic, continuous ship unloading (CSU) systems. The shells of the grabs themselves can have an open, semi-closed or completely enclosed upper part and are able to operate in every kind of opening direction.

CSU systems are pneumatic transshipment systems which are mainly used for ship unloading. Janzé [60] states that pneumatic ship unloaders needs to be avoided where possible, because they cause relatively large particle degradation due to high velocity impacts during operation. However, pneumatic systems are sometimes preferable as they can reach a high throughput with their flexible design.

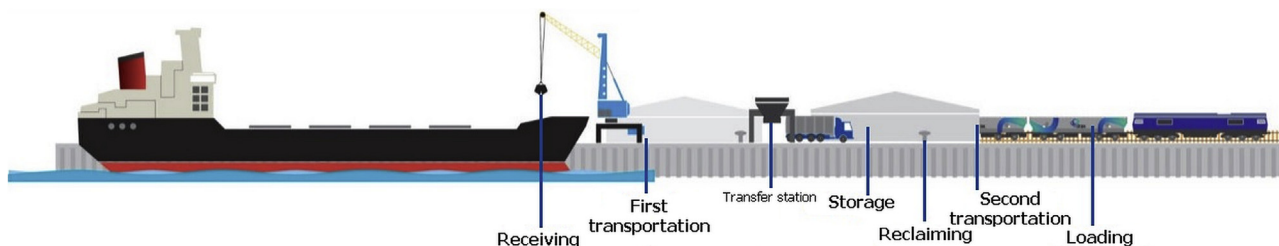

Fig. 1. Example of a solid bulk material handling chain [57,58].

Truck and rail unloading can be done in several ways; the truck or wagon carrier tips its load into a reception bunker or the whole truck or wagon is tipped. Furthermore, underground hoppers that lead to conveyor belt can be used to unload the truck or rail wagons. This option however requires trucks and wagons fitted with bottom unloading systems.

2.3.2. Transportation and transfer

After unloading, bulk materials need to be transported to a storage area. This can be performed by conveying equipment. In this section the most commonly used options for wood pellet transfer are discussed. The transfer from one conveyor to another one can be done through transfer stations along the transportation line.

Belt conveyors are more cost effective over large distances than, for example, screw conveyors, because of their high throughput and relatively low power requirements. Belt conveyors can be totally enclosed, which improves dust control (compared to regular open conveyors). However, they can be expensive to install and intermediate discharges are problematic. When choosing a belt conveyor for wood pellets, systems that encourage impacts or rubbing, wedging or grinding actions need to be avoided, as they can cause damage to the material.

Pouch and pipe conveyors do not need a cover to protect the pellets against, for example, wind, spillage, contamination or rain, and improve dust control as can be seen in Fig. 3 and Fig. 4. According to Janzé [60] a pipe conveyor is an ideal transport equipment for handling pellets, because it can accommodate both vertical and horizontal curves and therefore minimize the number of transfer points. On the other hand, Wu et al. [40] state that the pipe conveyor is not applicable for a large-scale pellet bulk terminal, because it is more costly, requires extra coverage distances for opening and closing (folding) of the pipe, and in addition, a pipe conveyor cannot cope with a ship unloader that moves along the quay of the terminal. However, they can be an ideal solution for small terminal sizes or really short transportation distances. The Ferrybridge power station in the United Kingdom for example, uses these pipe conveyors over a distance of 500 m to transport the wood pellets to a storage silo [61].

When handling pellets, the number of transfer points must be as low as possible to minimize the impact points and by that particle degradation and dust emission. A gentle transfer design can avoid knocking dust out of the flow. Spiral or cascade loading chutes are preferred, because pellets falling from a great height in a silo will break apart. Fans can create a negative pressure that directs dust into the hopper and not in the surrounding area [58].

2.3.3. Storage

According to Williams et al. [62] there are 5 solid dry bulk storage types in use; silos, dome storage, flat storage, bunkers and bins. Silos, dome and flat storage are the most common types used and are covered in this section.

Covered storage is needed when dealing with wood pellets, as high moisture contents can result in material degradation. Enclosed storage also prevents dust from spreading. Furthermore the storage needs to be large enough to accommodate the peak throughput of pellets due to seasonal fluctuations of energy supply and demand [63,64].

The silos' and domes' loading- and unloading systems are very economical and efficient. They are frequently used in power plants and port terminals. The construction can be made from concrete or steel and can reach up to 100 000 m³ of available storage capacity. The expensive concrete storage systems are desirable for high throughput due to its durability, whereas steel silos are more economical though not quite as durable. The pellet silos and domes are emptied through either a tapered bottom or underground hopper system respectively (emptied by gravity) or a flat bottom emptied using a circulating auger for centre feed [65]. The maintenance and discharge time required for flat bottom storage is usually longer.

The flat storage buildings are an economical and efficient design

and consists of high bunker style walls with a metal building or hoop type structure over the top of retaining walls. The volume for this large storage type can range from 15 000–100 000 m³. Loading and discharging of flat storage facilities can be fully automated, but usually will involve a labor intensive, thus expensive, step in the chain. Emptying is done mostly by a front loader either into a feed system for a boiler (power plant site) or onto trucks, vessels or rail cars for further transportation.

2.3.4. Reclaiming

After storage, the pellets need to be reclaimed for further transport to another location within the port (preferably following the 'first-in, first-out' principle), like the loadout system [60]. A requirement of the reclaiming system is that it should be adequate for enclosed storage and enclosed transport systems. Wu et al. [40] has listed several types of reclaimers that can be used for enclosed storage facilities, but these reclaiming systems are not specifically designed for wood pellets. However, there are several types of reclaimers that are designed (or adjusted) to handle the material.

The most common reclaiming system is a series of underground hoppers beneath the storage infrastructure. Most of the wood pellets (up to 80% of the capacity) are emptied via the hoppers into a conveyor belt and transported to the next stage. The remaining amount has to be manually fed into the hoppers via manual labor, usually with front loaders. This system is preferred due to low costs and simplicity of design, installation and maintenance compared to other, mechanically complex approaches.

Other reclaiming systems include equipment designed for difficult bulk solids, such as walking or vibrating floors and sliding frames (Fig. 5 and Fig. 6). Further advantages of these systems are that they work on the 'first-in, first-out' principle, have low power use and maintenance costs and can be placed in the economical flat storage buildings.

An overview of the most commonly used handling equipment for wood pellets found in port terminals can be found in Fig. 7.

3. Results

This section presents the way several of the biggest terminals in the Port of Rotterdam that engage in wood pellet trade handle the material. Between 2010 and 2014 the Netherlands imported approximately 1 Mt of wood pellets per annum, exclusively through the 3 port terminals examined in this section [66–68]. In 2015 and 2016 there was no sizeable imports of wood pellets in the Netherlands, due to the previous subsidy scheme running out – 75 kt in 2015 and 56 kt in 2016 respectively [69]. However, the market is expected to pick up in 2018 as plant operators managed to re-secure subsidies for co-firing of biomass. An overview of the examined terminals can be found in Table 2.



Fig. 3. Pouch conveyor (Image courtesy of ContiTech AG).



Fig. 4. Pipe conveyor (Image courtesy of Bridgestone Corporation).



Fig. 5. Walking floor reclaimer (Image courtesy of Stobart Group Limited).

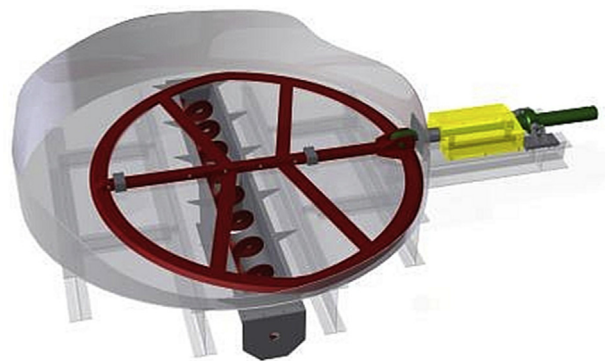

Fig. 6. Sliding frame reclaimer (Image courtesy of Spirac Engineering AB).

3.1. European Bulk Services (EBS) B.V

European Bulk Services (EBS) B.V. is a multipurpose dry bulk terminal operator working out of two terminals located in the Rotterdam port area, Europoort and St. Laurens haven. The St. Laurens haven terminal in Fig. 8 is used mainly for minerals coal and wood pellets. In 2013 EBS handled approximately 150 000 kt of wood pellets, almost 20% of the total solid biomass imports in the Netherlands.

3.1.1. Wood pellet handling

The wood pellets are unloaded with grabs directly from the vessel into a series of bunkers built along the quay side. There are no intermediate transfer points such as conveyor belts, hoppers or transfer

towers. Direct storage means less handling steps, less impact points and friction for the wood pellets which, as mentioned in Section 2.2, directly decreases the dust and fine production [72].

Unloading of the bunkers is also performed 100% through grabs. Grab operators have been instructed and trained to use lower speeds and gentler handling of the crane and grab when transferring the wood pellets from the vessel to the bunkers. The pellets are also dropped into the bunker from a lower point than other bulk material in order to minimize breakage. After reclaiming, pellets can be loaded in either barges or other vessels, or in trains or trucks. Loading and unloading stations for both are present in the terminal. A scheme of the EBS main pellet handling chain is seen in Fig. 9.

The grabs themselves are closed clam-shell grab models as seen in Fig. 2, especially suitable for handling fine and free flowing materials like wood pellets. They are equipped with high enclosed shells to minimize spillage and the influence of wind on the material. The grab shape is designed in such a way that compression of material is minimized (see Fig. 10). As a result the pellets are damaged as little as possible during the grabbing cycle. The open upper side of the grab enables the crane operator to manually check the filling degree.

If the quay bunkers get full, 4 pyramid silos (see Fig. 8) of 20 000 m³ each are also available as storage space. In this case, a conveyor belt system is used for transportation of the pellets. Dust control systems are already in place, since the terminal is used for the handling of several fine materials, such as alumina and other minerals. However, due to the low volume of wood pellets traded so far, the silos have not yet been used for wood pellet storage.

Transshipment of wood pellets can also be performed in the St. Laurens haven terminal via floating cranes of 36 t capacity, to either lighten or completely discharge a vessel, transferring part or all the cargo in another vessel. In case of bigger vessels, board to board transshipment can also occur at the Europoort terminal using “dolphins”, fixed structures that extend the berth of a terminal or provide a mooring point.

No handling of wood pellets is performed during rain to prevent the biological hazards from increased moisture content, as well as deterioration of the product.

Except the specialized grabs, no other equipment used is uniquely tailored to deal with wood pellets, mainly due to the currently small market of the product. Normal conveyor belts, trucks and trains, as well as dust containment systems used during the handling of other fine materials are used when handling pellets.

3.1.2. Wood pellet storage

The quay side bunkers used for the enclosed storage are simple concrete structures with no reclaiming function except using grabs. The bunker sheds can open and close automatically and be controlled by the crane operator in order to limit the exposure of wood pellets to the outside environment as much as possible.

EBS requires from the incoming vessels to monitor and report the temperature of the cargo during the journey and before arriving to the terminal. In the past there have been false or inaccurate reports and assumptions of pellet temperatures that have led to self-ignition. Any temperature above 323 K is a cause for concern. A solution EBS uses is storing the material temporarily in floating barges to minimize security risk until it has cooled down enough to allow storage in the bunkers.

The temperature in the bunkers is monitored with temperature ‘sticks’ dispersed throughout the piles. Temperature is monitored each second and the temperature gradient over time is also reported. A steep increase in temperature may lead to removing part of the material with grabs to a temporary storage in order to cool it down. Different quality and property types of pellets are not stored together. In the past, this practice led to a fire breaking out in a 30 000 m³ silo, burning for 3 weeks before destroying the silo and the material [73].

Constant gas measurements in the bunkers are also performed in order to avoid asphyxiation conditions.

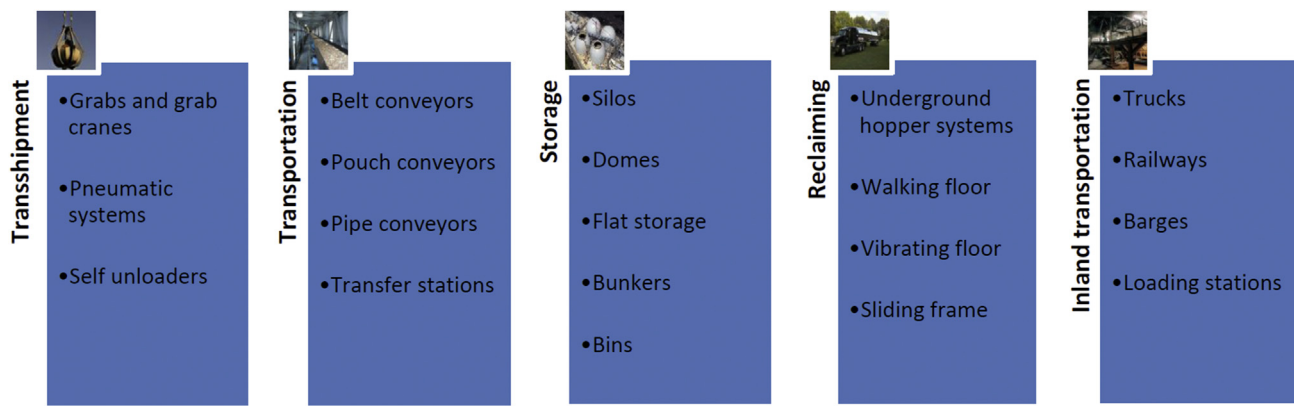

Fig. 7. Overview of wood pellet handling equipment.

3.1.3. Other issues

According to several terminal operators, a major problem concerning fine production is lack of prior information [72]. The terminal operator does not know and cannot control what happens to the material on the source side. Inadequate conditions and operations there can lead to a large presence of fines in the material delivered to the terminals, for which the operators are responsible. Efforts are being made by EBS to improve communication and knowledge of the source regions and operators as well.

EBS believe that in the case of wood pellets becoming more of a commodity market in Northwest Europe, much like in the UK, specialized handling and storage methods can be used. Drax's specialized rail wagons are an example [18].

3.2. Zeehavenbedrijf Dordrecht (ZHD) B.V

Zeehavenbedrijf Dordrecht (ZHD) B.V. is an independent stevedoring company operating in Dordrecht, Moerdijk and with a floating terminal at Rotterdam. It regularly handled around 300 to 400 kt of wood pellets per year (peaking at 500 kt), representing more than half of the Port of Rotterdam total wood pellet imports. ZHD was the main supplier of the RWE Amercentrale and the Vattenfall power plants before the previous subsidy scheme ran out and the plants stopped co-firing wood pellets. In 2013, 50% of the wood pellet imports through ZHD went to residential clients, primarily in Germany.

3.2.1. Wood pellet handling

ZHD uses mainly direct transshipment from ocean-going vessels to barges (see Fig. 12), operating with the 'just in time' delivery principle to their customers in order to avoid higher transportation and storage costs. Vessels served can reach up to Supermax - Handymax sizes (40 000–60 000 t). They are unloaded via cranes on the quay side or with the operators floating cranes that can reach up to 10 000 t per day of discharge capacity. The operators floating terminal allows no limitations to ship draft size and can service Capesize vessels as well, if pellets imports increase to the point where using vessels of this size is

profitable. A scheme of the ZHD main pellet handling chain is seen in Fig. 11.

Much like EBS, unloading of vessels and loading of barges and coasters is done in a gentle way. ZHD offers a 'soft landing' contract clause to its clients. This ensures that handling is done in a way that prevents as much as possible damage to the product by lowering the grab more into the barge while loading, spreading the product evenly in the bottom of the barge to provide a 'cushion' for the next load and maintaining low speeds throughout the procedures. The constant transshipment enables cooling down of the product at the same time [74,75].

If the wood pellets need to be stored, ZHD has 2 flat warehouses available. Transport of pellets to the warehouses is performed via trucks (the grabs load the truck with pellets) and discharge via front-loaders and manual labor into trucks as well. As in EBS, handling of wood pellets is conducted weather permitting.

Since almost the entirety of handling consists of vessel-to-vessel transfer, there are no dust control systems in place.

3.2.2. Wood pellet storage

The flat warehouses available have a height of 8.5 m and a capacity of 8000 t each. Flat storage was selected over silos as it was deemed that silos would be too hard to deal with in case of overheating and self-ignition, taking into account that the hot spot is usually located in the bottom of the piles. Pellets can be piled up to 7.5–8 m with the use of a push board.

Before the pellets are discharged from the vessel, a 'gas doctor' [76] goes on board to measure the gas levels and assess any potential danger from oxygen depletion or carbon monoxide generation. The temperature in storage is constantly monitored through temperature sensors on 'sticks' through the storage area. If the sensors report a high temperature, a manual checking is also performed and part of the material is transported to a barge until it cools off (usually in a weeks' time). All personnel working in the storage area is equipped with O₂ sensors. The warehouses are equipped with CO₂ sensors as well and both them and the equipment used is ATEX-proof; no spark sources are present in the

Table 2
Overview of wood pellet terminals in the Port of Rotterdam [70,71].

Terminal	European Bulk Services (EBS)	Zeehavenbedrijf Dordrecht (ZHD)	Rotterdam Bulk Terminal (RBT)
Annual throughput [Mt]	12	5	3
Wood pellet capacity [kt]	150	500	250 via storage - 700 via direct transshipment
Transshipment	Grabs and grab cranes	Grabs and grab cranes, floating cranes	Grabs and grab cranes
Transportation	Conveyor belts (when not in direct storage)	Trucks (when not in direct transshipment)	Conveyor belts
Storage	4 bunkers: total capacity 65 000 m ³ 4 silos: total capacity 80 000 m ³	2 flat warehouses: total capacity 16 000 m ³	6 silos: total capacity 72 000 m ³ 1 flat warehouse: capacity 20 000 m ³
Reclaiming	Grabs and grab cranes	Front loaders	5 underground hoppers Front loaders



Fig. 8. St Laurens haven terminal aerial view (Image courtesy of EBS BV).

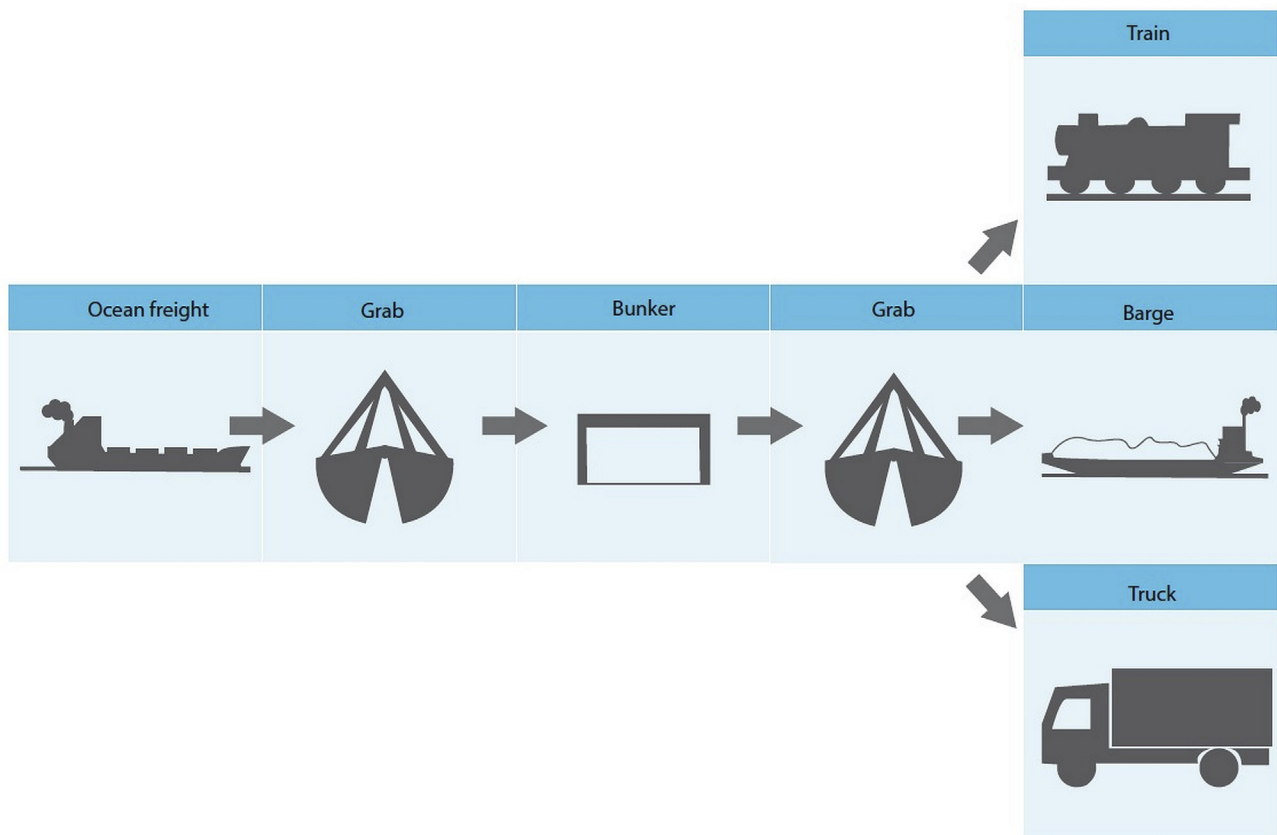

Fig. 9. EBS pellet handling chain.

vicinity and complete enclosure and overpressure in the front loaders' cabin are maintained.

Finally, one of the warehouses is equipped with a screening device to use before the final transport step, which enables the product to arrive to the client with as less fines as possible. Similar to the handling step, dust control systems are not in place, as, from experience, they are not required at the moment.

3.2.3. Other issues

As was mentioned in Section 3.1.3, product arriving with a large percentage of fines already present is a big problem. Fines can constitute up to 10–15% of the cargo in some extreme cases depending on the source and quality of the pellets. The inability to expect them only exacerbates the situation [74,75].

3.3. Rotterdam Bulk Terminal (RBT) B.V

Rotterdam Bulk Terminal (RBT) B.V. is a multipurpose dry bulk terminal operator in the port of Rotterdam. The terminal has direct access to the sea and inland waterways and can receive up to Handysize vessels. RBT was providing the Amercentrale Unit 9 with almost 6000 t per day of wood pellets, operating on the 'just in time' principle via direct transshipment (Fig. 13). A scheme of the RBT main pellet handling chain is seen in Fig. 14.

3.3.1. Wood pellet handling

Owing to the compact structure of the terminal, 80% of all operations are executed with gantries. When it is absolutely necessary, quicker discharge is easily fixed with help of floating cranes. Wood pellets are unloaded via grabs, irrespective of the procedure being a direct transshipment or intermediate storage. Handling with the grab is



Fig. 10. Closed clam-shell grab used in EBS terminal (Image courtesy of EBS BV).

done as gently as possible. In the case of intermediate storage the transportation of wood pellets is performed through a completely covered (but not 100% enclosed) 1500 m conveyor belt with a maximum capacity of $18\ 00\ t\cdot h^{-1}$ (Fig. 15). When transporting pellets the conveyor belt speeds are lower than when other bulk material is handled.

The silos and shed are filled through direct drop of the product (20 m height). Sviderski [77] reports that the first layer of the product shields the next layers from impact, restricting the fines to a percentage

of approximately 4% of the total product weight, a loss acceptable by the operator. Silo discharging is performed through 5 underground hoppers which allow two thirds of the silo to be emptied through the materials own weight (gravity discharge) while the remaining one third is discharged manually. The shed is discharged 100% through manual labor with front loaders.

According to RBT's experiences, dust explosions are not a danger when ATEX certified equipment is used during the loading and discharge of the facilities. The equipment operators have also followed courses per ATEX regulations. The conveyor belts are not completely enclosed, just covered, so that a dust explosion will not propagate through the belt. During rain, there is no work performed at all and the pellets remain stored in the source vessels [77].

3.3.2. Wood pellet storage

In direct transshipment there is no danger of self-heating and ignition of pellets, as the temperature drops by 298–303 K. Temperature in storage however is monitored constantly with temperature sensors on 'sticks'. The sticks are placed in the piles manually and transmit their readings to GPS boxes located in the facility. The readings are then forwarded to the offices of RBT in the premises. When a temperature higher than 333 K is reported, the storage area is cooled down through mechanical ventilation. Moreover, an amount of wood pellets can be discharged, circulated around the terminal grounds in the conveyor belts, and then brought in storage again. Nitrogen flooding of the silos is also possible in a fire breaks out. According to RBT's experience, temperature sticks in silos can be a problem when underground discharge is used, as the weight of the material tends to rip the sticks down from their holders.

Personnel that enter the enclosed storage spaces always do so in pairs and carry CO₂ sensors on them at all times to avoid suffocation or respiratory problems.

There is no screening system in place in the silos as it is a completely closed system. It is possible to have a screening system at the end of the handling chain coming from the flat storage, but this will happen only after direct request from the client who will have to bear the costs of the equipment.

4. Discussion

For the low amount of pellets going through the bulk terminals so far, operators report that with the described techniques presented in this paper, the end quality and safety of the product is within acceptable limits. However, none of the terminals is a dedicated pellet import terminal. They handle pellets as another product among many which

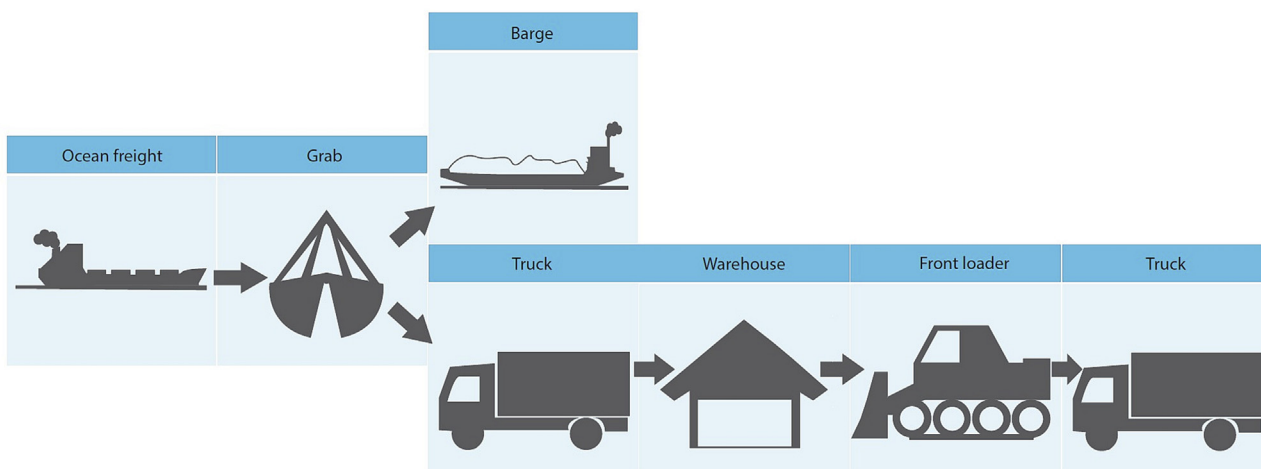

Fig. 11. ZHD pellet handling chain.



Fig. 12. Direct transshipment of wood pellets (Image courtesy of ZHD BV).



Fig. 13. Direct transshipment operation (Image courtesy of RBT BV).

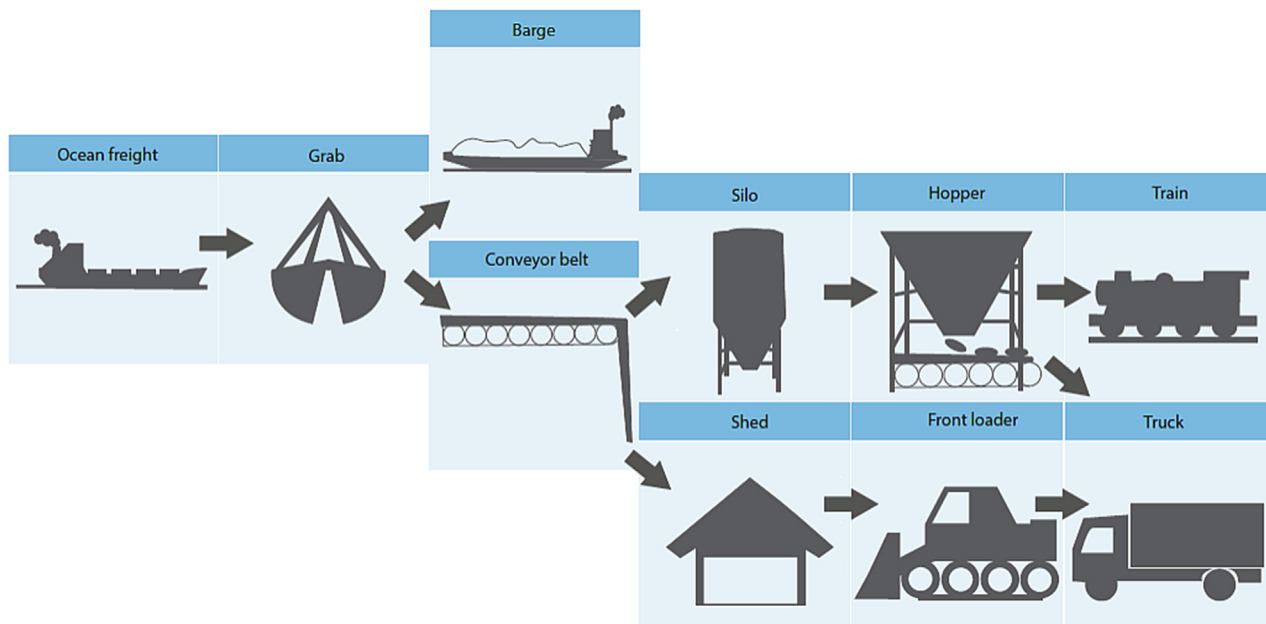

Fig. 14. RBT pellet handling chain.



Fig. 15. Rotterdam Bulk Terminal aerial view (Image courtesy of RBT BV).

make for several sub-optimal procedures in the chain; manual discharge, no screening equipment, limited dust prevention and containment measures. Major investments in infrastructure are also hindered by the relatively low cost contribution of terminal handling costs to the

overall wood pellet supply chain costs. Handling and storage in import terminal usually ranges between 2.5 and 5 €·t⁻¹, depending on factors such as relevant equipment, weather delays, or whether storage or direct transshipment is used [73,74,78]. With a (CIF ARA) spot price of

approximately 135 €·t⁻¹ [79,80] and a 'delivered to end user' price than can reach up to 200 €·t⁻¹ in continental Europe [81,82], reducing the terminal handling and storage costs seems trivial from an overall perspective. However, from a terminal operator's point of view, investing in dedicated wood pellet infrastructure and equipment is a major strategic decision that can have severe implication on their long-term planning strategy. Moreover, taking into account the future increased imports, several more stakeholders will benefit from dedicated equipment and terminals and a lower delivered wood pellet price. End users such as power plants, that may need to rely less on governmental subsidies, and households or industry, in the case of pellets used for heating purposes, will support lower wood pellet prices via dedicated or properly equipped import terminals.

As imports are expected to grow, and with ports transitioning into high volume wood pellet handling facilities as well, significant changes will be necessary; direct transshipment with floating cranes might no longer be an option, as floating cranes generally have 50% of the capacity of stationary gantry cranes of the same tonnage [59]. In the case of throughput in the range of 10 Mt per year or more, unloading using exclusively high capacity gantry cranes or CSU systems will be needed, although the CSU effect on the deterioration of the product will have to be taken into account. Transportation with trucks instead of a continuous conveyor cannot be the only possible option any more due to low capacity of the trucks. Fully enclosed instead of covered conveyors will be required, with state-of-the-art dust extraction systems and explosions prevention and suppression; as the volumes will increase, so will the chances of an accidental ignition and explosion. Currently, there is absolutely no handling during rain or otherwise unfavorable weather conditions. This is manageable, as for the present low throughputs there is no congestion of wood pellet vessels in the berths of the terminals. Extra demurrage costs are manageable due to the small vessel sizes (compared to the respective costs of coal). However, if the projected increases in wood pellet trade materialize, weather related operations will also become a major factor to be taken into account. Storage options will need to transition from numerous smaller buildings to fewer larger ones to keep costs down. At the same time, larger storage infrastructure could possibly mean longer storage times that leads to increased chances of self-heating and ignition. New storage options will need to be equipped with better temperature monitoring systems, as well as increased ventilation to keep temperatures down in the piles of material. Automated reclaiming systems might also need to be put into place, as manual labor is too time consuming and usually results in a much bigger percentage of fines in the material than e.g. a screw conveyor or sliding frame. Lastly, the personnel will need to undergo special training, just as some terminals in the Port of Rotterdam have already done, in order to familiarize themselves with the new equipment and techniques needed for safe and efficient handling of wood pellets.

Part of the terminals' existing infrastructure could be adopted for pellets in the short term future, with a relatively low cost. In general, however, larger scale throughputs require an elaborate and expensive monitoring and safety infrastructure, besides fully covered handling and storage [25]. Most systems that handle biomass do not start up and function effectively straight away – many need an extended period of development during which retrofit and lost opportunity costs are incurred, often for a year or two before they become fully operational [24]. All of the above constitute significant changes in the port terminals' design and operations and will require considerable investments in almost all aspects of a terminal's setup: infrastructure type and layout, personnel training and land availability. Research has been performed by the authors on optimizing the equipment deployment and operations in a dedicated biomass terminal [83]. One particular successful example of wood pellet import terminal setup is the facilities of Drax, one of the biggest providers of UK's electricity. As explained in the introduction, whilst Drax is at the extreme upper end of the size scale, the proportions and scale are similar in many projects [24], and it can

be used as a guideline to facilitate a successful wood pellet terminal setup.

Finally, equipment manufacturers are not always as well informed as the buyer (in this case the terminals) expect, when it comes to offering advice on the right 'tools for the job' [29]. Although the manufacturing companies are experts in equipment design, in certain cases they cannot be expected to know exactly how every possible material will behave and this in turn highly affects the equipment design itself – it is the buyer's responsibility to make sure suitable solutions are selected. It might be necessary at this stage to bring in more stakeholders, such as experts in material interaction to advise on the equipment design and selection process.

The authors acknowledge that the human factor of this research can be viewed as a limitation. However, the strict scope of the information exchange and the personal attestation of industrial wood pellet handling conditions constitute valid scientific data. The importance of the information gained from the above methods become more important when coupled with the limited scientific background on the subject and the difficult access to actual industrial data due to several reasons – confidentiality issues, industrial reticence to data sharing etc. These techniques are widely used in several scientific fields for the purpose of data gathering (e.g. residential or industrial sector data gathering from energy companies) with a high degree of success and credibility. A full list of interviewees can be found in the reference section of this paper.

Potential future research relating to wood pellets could focus on various aspects. Equipment interaction could be identified with greater accuracy; the compression, shearing and impact forces inflicted on pellets during handling and storage could be examined into more depth in order to identify which part of the chain to focus on to avoid associated problems. This will promote improving the design of currently used equipment and handling chains and developing new equipment or techniques for more efficient handling and storage. Regarding transport, more information is needed for the status of the material when it arrives in the port terminals; most terminal facilities report that there is no way of gaining prior information and have no control on the steps pellets go through from production until delivery to the terminal, which might result in shipments with an unacceptable number of fines present.

Research into innovation in wood pellet handling and storage has identified recent advances in these areas. Stammes [84] has pinpointed recent advances in the fields of explosion protection, which encompasses explosion resistant design, venting, suppression and isolation equipment and methods [85,86]. A promising solution to temperature related problems can be solved by monitoring closely with disposable passive RFID tags in wireless sensor networks [87,88].

Finally, there might be merit in researching the replacement of normal wood pellets, which constitute 100% of the co-firing fuel, with steam-treated or torrefied pellets [89]. These type of pellets are generally more energy intensive and more costly than conventional pellet production methods [90,91]. Yet, they have a higher calorific value than normal wood pellets, they are more resistant to moisture and degradation and generally can make use of conventional bulk equipment with minimal to no need for retrofitting or replacing infrastructure [92], resulting in greater operational flexibility with lower investments. However, despite the co-firing industry being a front-runner of torrefaction research, there is little available data about current use of torrefied pellets in industrial applications, and limited knowledge of its implementation in industries such as the chemical and petrochemical industry, pulp and paper etc. [30]. The market of torrefied pellets is relatively on the earlier stage and its future seems unclear [90,92].

5. Conclusions

The main objective of this study was to evaluate the state-of-the-art conditions relating to wood pellet handling in import terminals, and

where the terminal design needs to be reexamined to efficiently handle the expected increase in pellet imports. In conclusion we find that:

When dealing with wood pellets, special care is given in order to prevent the degradation of the material due to handling forces acting on it, minimizing dust and fine production. This is mainly performed through lowering the speed of the grab cycle, the height of the drop and training personnel specifically on how to handle the material. Some terminals have eliminated the need for conveying all together in most cases by having storage facilities located right next to the quay or by using direct transshipment. Others mainly use covered conveyor belts for transport of the wood pellets to storage facilities. The conveying distance is kept as short as possible and the belt speeds when handling pellets are lower than usual. Handling of wood pellets is not performed during rain to avoid deterioration of the quality of the product in the short term and mold growth which leads to biological hazards in the long term. In any case, containment and extraction of dust and particulates and ensuring a dry environment throughout the chain is of the highest priority.

Self-heating and ignition is considered as the major problem inherent with wood pellet handling and storage. Temperature is monitored continuously in storage and in some cases vessel holds. ATEX equipment and procedures are in place and ignition sources are avoided. When high temperatures are reported material is removed temporarily, either to a different storage area or recirculated in order to allow it to cool down. Temperature monitoring systems are functioning continuously, especially in enclosed facilities. Gas (CO, CO₂) and oxygen measurements are also performed often and all personnel who enter enclosed facilities carry gas and oxygen sensors.

The majority of the bulk equipment and facilities designed for other bulk commodity goods is used for wood pellets as well, and can be suboptimal (e.g. hopper design in RBT). The port terminals' need to use manual labor in certain cases (front-loaders in warehouses, physical engagement in others) showcases the fact that not all equipment is fit for handling material with different properties. Still, the current setup and equipment in bulk terminals, geared mainly towards coal, iron ore and other material with different properties than wood pellets, can deal with low volumes of pellet throughput. If the expected increases in wood pellet imports materialize, most import terminals will have to invest in adjusting their approach, either by retrofitting existing facilities, or creating new ones altogether. The focus should be primarily put on two aspects. Transportation of high volumetric capacity and adequate storage capacity. Both of these aspects will need to comply to the strict safety measures and regulations discussed in this research.

Acknowledgements

This work is part of the BioLogikNL project, which aims to develop knowledge of the logistics chains of biomass from abroad to the Netherlands. It was made possible by the financial support from the 'Subsidieregeling Energie en Innovatie Biobased Economy: Kostprijsreductie Elektriciteit-en Warmteproductie.' (Grant No. TEBE213008) The authors are also grateful to the representatives of the respective terminals and facilities for their helpful cooperation in setting up the meetings and providing all the relevant information.

References

- [1] European Biomass Association, AEBIOM statistical report - key findings, <http://www.aebiom.org/wp-content/uploads/2016/12/AEBIOM-KEY-FINDINGS-REPORT-2016.pdf>, (2016).
- [2] S. Proskurina, R. Sikkema, J. Heinimö, E. Vakkilainen, Five years left – how are the EU member states contributing to the 20% target for EU's renewable energy consumption; the role of woody biomass, *Biomass Bioenergy* 95 (2016) 64–77, <https://doi.org/10.1016/j.biombioe.2016.09.016>.
- [3] T. Mai-Moulin, L. Visser, M. Junginger, Sourcing overseas biomass for EU ambitions: assessing net sustainable export potential from various sourcing countries, *Biofuels Bioprod. Biorefining* (2018), <https://doi.org/10.1002/bbb.1853>.
- [4] I. Dafnomilis, R. Hoefnagels, Y.W. Pratama, D.L. Schott, G. Lodewijks, M. Junginger, Review of solid and liquid biofuel demand and supply in Northwest Europe towards 2030 – a comparison of national and regional projections, *Renew. Sustain. Energy Rev.* 78 (2017), <https://doi.org/10.1016/j.rser.2017.04.108>.
- [5] L. Paolotti, G. Martini, A. Marchini, R. Pascolini, A. Boggia, Economic and environmental evaluation of transporting imported pellet: a case study, *Biomass Bioenergy* 83 (2015) 340–353, <https://doi.org/10.1016/j.biombioe.2015.09.011>.
- [6] Social and Economic Council of the Netherlands, Energy agreement for sustainable growth, <https://www.ser.nl/en/publications/publications/2013/energy-agreement-sustainable-growth.aspx>, (2013).
- [7] I. Dafnomilis, Y.P. Wachyar, D.L. Schott, M. Junginger, R. Hoefnagels, *Bioenergy Development in the Netherlands*, (2015) doi:2015.TEL.8045.
- [8] D. Thrän, *Global Wood Pellet Industry and Trade Study 2017*, IEA Bioenergy Task 40, (June 2017) 978-1-910154-32-8.
- [9] W. Strauss, *Industrial wood pellet fuel in pulverized coal power plants*, BioCleantech Forum, Ottawa, Canada, 2016.
- [10] L. du Plessis, *Japan's biomass market overview*, JETRO London, 2015.
- [11] J. Carter, *New Opportunities for Biomass Growth: Japan and South Korea*, (2017) <https://blog.forest2market.com/new-opportunities-for-biomass-growth-japan-and-south-korea>, Accessed date: 5 August 2017.
- [12] *International Trade Administration (ITA)*, 2016 Top Markets Report Renewable Fuels Country Case Study: South Korea, (2016).
- [13] W. Strauss, *Global Industrial Wood Pellet Markets – Future Demand and Future Prices (White Paper)*, Futur. Metrics, (2016).
- [14] V.E. Hancock, I. Dafnomilis, D.L. Schott, G. Lodewijks, *Torrefied Biomass and its Handling Aspects – a State-of-the-art Review*, Bulk Mater. Storage, Handl. Transp., Darwin, Australia, 2016.
- [15] W. Strauss, *Overview of wood pellet Co-firing, Co-firing Work*, 2016 <http://www.biomasscofiring.ca/images/stories/PDFs/WoodPelletCo-firingOverviewFutureMetrics.pdf>.
- [16] Drax Group PLC, *Building a 21st century port*, <https://www.drax.com/sustainability/21centuryport/>, (2016), Accessed date: 5 November 2017.
- [17] Drax Group PLC, *About us*, (2017). <https://www.drax.com/about-us/> (accessed November 5, 2017).
- [18] *Railway Gazette*, *Drax unveils high-volume biomass wagon*, <http://www.railwaygazette.com/news/traction-rolling-stock/single-view/view/drax-unveils-high-volume-biomass-wagon.html>, (2013), Accessed date: 1 January 2015.
- [19] Oxford Economics, *The Economic Impact of Drax Group in the UK*, (2016) www.huawei.com/ilink/uk/download/HW_441177.
- [20] H. du Mez, *Advisor business intelligence - dry bulk, port of Rotterdam authority*, (May 11th 2017). Personal communication.
- [21] *Port of Rotterdam Authority*, *European hub for biomass*, (2013) <https://www.portofrotterdam.com/nl/file/843/download?token=wg3CckF%0A>.
- [22] W. Stelte, *Guideline: Storage and Handling of Wood Pellets*, Danish Technological Institute (DTI), 2012.
- [23] *Nordic Innovation Centre*, *Guidelines for storing and handling of solid biofuels*, NT ENVIR 010 (2008) URN: urn:nbn:se:lnu:diva-6812.
- [24] J.R. Berry, *Advances in Materials Handling Solutions for Biomass*, Wolfson Centre for Bulk Solids Handling Technology, University of Greenwich, 2012.
- [25] A. Rossner, C.E. Jordan, C. Wake, L. Soto-Garcia, *Monitoring of CO in residences with bulk wood pellet storage in the northeast*, *J. Air Waste Manag. Assoc.* 2247 (2017), <https://doi.org/10.1080/10962247.2017.1321054>.
- [26] S. Proskurina, H. Rimppi, J. Heinimö, J. Hansson, A. Orlov, K. Raghu, E. Vakkilainen, *Logistical, economic, environmental and regulatory conditions for future wood pellet transportation by sea to Europe: the case of Northwest Russian seaports*, *Renew. Sustain. Energy Rev.* 56 (2016) 38–50, <https://doi.org/10.1016/j.rser.2015.11.030>.
- [27] S. Graham, C. Eastwick, C. Snape, W. Quick, *Mechanical degradation of biomass wood pellets during long term stockpile storage*, *Fuel Process. Technol.* 160 (2017) 143–151, <https://doi.org/10.1016/j.fuproc.2017.02.017>.
- [28] S. Graham, I. Ogunfayo, M.R. Hall, C. Snape, W. Quick, S. Weatherstone, C. Eastwick, *Changes in mechanical properties of wood pellets during artificial degradation in a laboratory environment*, *Fuel Process. Technol.* 148 (2016), <https://doi.org/10.1016/j.fuproc.2016.03.020>.
- [29] M.S.A. Bradley, *Biomass fuel transport and handling*, *Fuel Flex. Energy Gener. Solid, Liq. Gaseous Fuels*, Elsevier Ltd, 2016, <https://doi.org/10.1016/B978-1-78242-378-2.00004-3>.
- [30] M.C. Carbo, P.M.R. Abalha, M.K. Cieplik, C. Mourao, J.H.A. Kiel, *Fuel pre-processing, pre-treatment and storage for co-firing of biomass and coal*, *Fuel Flex. Energy Gener. Solid, Liq. Gaseous Fuels*, Elsevier Ltd, 2016, <https://doi.org/10.1016/B978-1-78242-378-2.00005-5>.
- [31] D. Ilic, K. Williams, R. Farnish, E. Webb, G. Liu, *On the challenges facing the handling of solid biomass feedstocks, Biofuels, Bioprod. Biorefining* 12 (2018) 187–202, <https://doi.org/10.1002/bbb.1851>.
- [32] *United Nations Conference on Trade and Development (UNCTAD)*, *Development and Improvement of Ports - Development of Bulk Terminals*, (1985).
- [33] *United Nations Conference on Trade and Development (UNCTAD)*, *Handbook on the Management and Operation of Dry Ports*, (1991).
- [34] F.E. Agos, *Multi-purpose Port Terminals. Recommendations for Planning and Management*, UNCTAD Monogr. Port Manag. United Nations Publications, 1991 UNCTAD/SHIP/494(9).
- [35] *United Nations Conference on Trade and Development (UNCTAD)*, *Port performance indicators*, http://unctad.org/en/PublicationsLibrary/tdbc4d131sup1rev1_en.pdf, (1976).
- [36] E.G. Frankel, J. Cooper, Y.W. Chang, G. Tharakan, *Bulk Shipping and Terminal Logistics*, (1985) World Bank technical paper no.38, ISBN: 0-8213-0531-X.
- [37] D.L. Schott, G. Lodewijks, *Analysis of dry bulk terminals: chances for exploration*,

- Part. Part. Syst. Char. 24 (2007), <https://doi.org/10.1002/ppsc.200601121>.
- [38] M.R. Wu, D.L. Schott, G. Lodewijks, Physical properties of solid biomass, *Biomass Bioenergy* 35 (2011) 2093–2105, <https://doi.org/10.1016/j.biombioe.2011.02.020>.
- [39] G. Towler, R. Sinnott, *Specification and Design of Solids-handling Equipment*, Elsevier Ltd, 2013, <https://doi.org/10.1016/B978-0-08-096659-5.00018-3>.
- [40] M. Wu, A Large-scale Biomass Bulk Terminal, PhD Dissertation Delft University of Technology, 2012, <https://doi.org/10.4233/uuid:cfb51421-504d-46df-8309-e10ac65dbbc3>.
- [41] S. Proskurina, E. Alakangas, J. Heinimö, M. Mikkilä, E. Vakkilainen, A survey analysis of the wood pellet industry in Finland: future perspectives, *Energy* 118 (2017) 692–704, <https://doi.org/10.1016/j.energy.2016.10.102>.
- [42] D. Duca, G. Riva, E. Foppa Pedretti, G. Toscano, Wood pellet quality with respect to EN 14961-2 standard and certifications, *Fuel* 135 (2014) 9–14, <https://doi.org/10.1016/j.fuel.2014.06.042>.
- [43] International Organization for Standardization (ISO), ISO 17831–1: solid biofuels - determination of mechanical durability of pellets and briquettes - Part 1: Pellets, <http://www.hse.gov.uk/electricity/standards.htm>, (2015).
- [44] S.H. Larsson, R. Samuelsson, Prediction of ISO 17831-1:2015 mechanical biofuel pellet durability from single pellet characterization, *Fuel Process. Technol.* 163 (2017), <https://doi.org/10.1016/j.fuproc.2017.04.004>.
- [45] D.L. Schott, R. Tans, I. Dafnomilis, V. Hancock, G. Lodewijks, Assessing a durability test for wood pellets by Discrete element simulation, *FME Trans* (2016) 279–284, <https://doi.org/10.5937/fmet1603279S>.
- [46] A. Mahajan, I. Dafnomilis, V. Hancock, G. Lodewijks, D.L. Schott, Assessing the representativeness of durability tests for wood pellets by DEM Simulation – comparing conditions in a durability, *Powders & Grains*, 2017, pp. 1–4.
- [47] C. Whittaker, I. Shield, Factors affecting wood, energy grass and straw pellet durability – a review, *Renew. Sustain. Energy Rev.* 71 (2017) 1–11, <https://doi.org/10.1016/j.rser.2016.12.119>.
- [48] I. Dafnomilis, L. Lanphen, D.L. Schott, G. Lodewijks, Biomass handling equipment overview, *Mater. Handl. Constr. Logist.*, Vienna, Austria, 2015, pp. 66–70.
- [49] International Organization for Standardization (ISO), ISO 17225–1: solid biofuels - fuel specifications and classes - Part 1: general requirements, <https://www.iso.org/obp/ui/#iso:std:iso:9241:-11:ed-2:v1:en>, (2014).
- [50] C. Huéscar Medina, H.N. Phylaktou, H. Sattar, G.E. Andrews, B.M. Gibbs, The development of an experimental method for the determination of the minimum explosible concentration of biomass powders, *Biomass Bioenergy* 53 (2013) 95–104, <https://doi.org/10.1016/j.biombioe.2013.03.008>.
- [51] J. Lottermann, *The Underestimated Explosion Hazards of Solid Biofuels*, (2015) doi:2014.TEL.7893.
- [52] F. Yazdanpanah, S. Sokhansanj, C.J. Lim, A. Lau, X. Bi, S. Melin, Stratification of off-gases in stored wood pellets, *Biomass Bioenergy* 71 (2014) 1–11, <https://doi.org/10.1016/j.biombioe.2014.04.019>.
- [53] M. Röder, C. Whittaker, P. Thornley, How certain are greenhouse gas reductions from bioenergy? Life cycle assessment and uncertainty analysis of wood pellet-to-electricity supply chains from forest residues, *Biomass Bioenergy* 79 (2014) 50–63, <https://doi.org/10.1016/j.biombioe.2015.03.030>.
- [54] N.S. Khan, *Best Practice Guide for Handling of Biomass Fuels and Coal - Biomass Mixes*, (2011).
- [55] C.D. Memos, *Port planning, Port Eng Planning, Constr Maintenance, Secur*, John Wiley & Sons, New Jersey, 2004.
- [56] I. Obernberger, G. Thek, *The Pellet Handbook – the Production and thermal Utilization of Biomass Pellets*, Routledge, 2010 ISBN: 1136539913, 9781136539916.
- [57] M. Rivers, *Biomass Sourcing Strategies*, (2013) http://www.drax.com/media/13853/2_cmd_biomass_markets_final.pdf.
- [58] L. Lanphen, *Biomass Handling Equipment in European Ports - an Overview of Current Designs and Required Design Improvements*, (2015) doi:2014.TEL.7893.
- [59] M. Corbeau, General Manager, Nemaq BV, (May 11th 2017). Personal Communication.
- [60] P. Janze, *Biomass Handling Handling Pellets – Things to Consider*, (2016), pp. 1–8 <http://www.advancedbiomass.com/2010/10/handling-pellets-things-to-consider/>, Accessed date: 1 June 2017.
- [61] A. Mills, *Ferrybridge Power Station*, (2016) <https://portasilo.com/sectors/energy-from-waste-and-power/ferrybridge-power-station/>, Accessed date: 5 June 2017.
- [62] G.D. Williams, *Biomass storage and handling: status and industry needs*, American Society of Agricultural and Biological Engineers (ASABE) Annual International Meeting, Providence, Rhode Island, USA, 2008.
- [63] J. Ruijgrok, Managing Director, ESI Eurosil BV, (November 9th 2016). Personal Communication.
- [64] C. Geijs, Project Engineer, ESI Eurosil BV, (November 9th 2016). Personal Communication.
- [65] P. Basu, *Biomass Handling*, first ed., Elsevier Inc, 2013, <https://doi.org/10.1016/B978-0-12-396488-5.00012-5>.
- [66] W. Van Der Lans, *Bio-synergy in the Port*, (2016).
- [67] Port of Rotterdam Authority, Rotterdam bio port: our contribution to a biobased economy, <http://www.rotterdamclimateinitiative.nl/documents/2015-en-ouder/Documenten/Position%20Paper%20RCI%20Biobased-economie%20ENGELS%2010-2014%20LR%20DEF.pdf>, (2013), Accessed date: 13 May 2017.
- [68] Port of Rotterdam Authority, *Jaarverslag 2014*, (2014), <https://doi.org/10.1007/s13398-014-0173-7-2>.
- [69] Port of Rotterdam Authority, *Jaarverslag 2016*, (2016) <https://jaarverslag2016.portofrotterdam.com/>, Accessed date: 10 August 2017.
- [70] Port of Rotterdam Authority, *Dry Bulk Companies*, (2016) <https://www.portofrotterdam.com/sites/default/files/dry-bulk-companies.pdf>, Accessed date: 8 July 2017.
- [71] RBT, *700 000 tonne Coal Transshipment Capacity in the Port of Rotterdam, Dry Cargo*, (2012).
- [72] F. van der Stoep, Sales Manager, European Bulk Services (EBS) BV, (October 21st 2015). Personal Communication.
- [73] L. Ljungblom, Pellets: booming in Rotterdam, <http://www.novator.se/bioint/bioint904.pdf>, (2004), Accessed date: 1 January 2015.
- [74] L. Lokker, Commercial Director, ZHD Stevedoring, (November 17th 2015). Personal Communication.
- [75] D. Regoord, Sales Manager, ZHD Stevedoring, (November 17th 2015). Personal Communication.
- [76] British Government Health and Safety Executive, *Wood pellet bio-fuel*, <http://www.hse.gov.uk/confinedspace/updates/wood-pellet-fuels.htm>, (2012).
- [77] B. Sviderski, Commercial Manager, Rotterdam Bulk Terminal (RBT) BV, (November 14th 2015). Personal Communication.
- [78] B. Pothoven, Business Analyst and Insurance Manager, Europees Massagoed Overslag (EMO) BV, (May 11th 2015). Personal Communication.
- [79] Argus Media, *Biomass Markets*, (2016) <http://media.argusmedia.com/~media/Files/PDFs/Samples/Argus-Biomass.pdf>, Accessed date: 5 November 2017.
- [80] W. Strauss, *Global Pellet Market Outlook in 2017*, Wood Pellet Assoc, Canada, 2017 <https://www.pellet.org/wpac-news/global-pellet-market-outlook-in-2017>, Accessed date: 5 November 2017.
- [81] FOEX Indexes Ltd, *Bioenergy and Wood Indices*, (2017) <http://www.foex.fi/biomass/>, Accessed date: 8 November 2017.
- [82] L. Blair, *Wood pellet market update*, Nord. Balt. Bioenergy Conf., Hawkins Wright, Helsinki, 2017.
- [83] I. Dafnomilis, M.B. Duinkerken, M. Junginger, G. Lodewijks, D.L. Schott, Optimal equipment deployment for biomass terminal operations, *Transport. Res. Part E Logist. Transp. Rev.* 115 (2018), <https://doi.org/10.1016/j.tre.2018.05.001>.
- [84] S.A. Stammes, *Innovative Approaches in Woody Biomass Handling and Storage*, (2017) doi:2017.TEL.8140.
- [85] A. Tascon, Design of silos for dust explosions: determination of vent area sizes and explosion pressures, *Eng. Struct.* 134 (2017) 1–10, <https://doi.org/10.1016/j.engstruct.2016.12.016>.
- [86] Atex Explosion Hazards, *Explosion Prevention in the Biomass Industry*, (2017) <http://www.explosionhazards.co.uk/explosion-prevention-biomass-and-waste-industry/>, Accessed date: 24 May 2017.
- [87] Phase IV Engineering, *RFID Temperature Sensors*, (2017) <http://www.phaseivengr.com/product-category/rfid-battery-free-passive-wireless-sensors/rfid-passive-battery-free-temperature-sensors/>, Accessed date: 29 May 2017.
- [88] B. Kvarnström, E. Vanhatalo, Using RFID to improve traceability in process industry, *J. Manuf. Technol. Manag.* 21 (2009) 139–154, <https://doi.org/10.1108/17410381011011524>.
- [89] J.H. Miedema, R.M.J. Benders, H.C. Moll, F. Pierie, Renew, reduce or become more efficient? The climate contribution of biomass co-combustion in a coal-fired power plant, *Appl. Energy* 187 (2017), <https://doi.org/10.1016/j.apenergy.2016.11.033>.
- [90] J. McKechnie, B. Saville, H.L. MacLean, Steam-treated wood pellets: environmental and financial implications relative to fossil fuels and conventional pellets for electricity generation, *Appl. Energy* 180 (2016), <https://doi.org/10.1016/j.apenergy.2016.08.024>.
- [91] D.A. Agar, A comparative economic analysis of torrefied pellet production based on state-of-the-art pellets, *Biomass Bioenergy* 97 (2017) 155–161, <https://doi.org/10.1016/j.biombioe.2016.12.019>.
- [92] S. Proskurina, J. Heinimö, F. Schipfer, E. Vakkilainen, Biomass for industrial applications: the role of torrefaction, *Renew. Energy* 111 (2017), <https://doi.org/10.1016/j.renene.2017.04.015>.