

## REDUCING THE RANDOM SEED EFFECT ON SEGMENTATION BY APPLYING AN EDGE-PRESERVING FILTER

E.A. Addink

Department of Physical Geography, Faculty of Geosciences, Utrecht University, POBox 80115, 3508 TC Utrecht, The Netherlands – (e.a.addink@uu.nl)

**KEY WORDS:** object definition, segmentation

### ABSTRACT:

In region-growing segmentation algorithms random seed locations are used (reference). To ensure that repeating the segmentation will produce the same result, the seed locations are following a fixed random pattern. Empirical studies show that when the image that is subjected to the segmentation is changed by adding or removing rows or columns, the resulting segments are not identical anymore, the so-called seed effect. This occurs not only at the border of the image as one would intuitively expect, but also in the center part of the image. Apparently, the exact location of a seed affects the resulting segment.

In this study I investigated whether application of an Edge-Preserving Smoothing Filter to an image prior to segmentation would reduce the effect of seed locations when rows or columns are added or removed from that image, and hence make the segmentation method by random seeds more robust. Two images were included: an IKONOS image of the central part of the Netherlands with fragmented land cover of agriculture, forest and villages and a SPOT5 2.5m multi-spectral image of a semi-desert steppe area in southeastern Kazakhstan. Both images were subjected to an Edge-Preserving Smoothing Filter before segmentation. This filter calculates variance for each band in nine different directions (8 wind directions + central area) and sums them per direction. The average band values of the direction with the lowest overall variance are then assigned to the central pixel.

For both areas four subsets, each measuring 500x500 pixels, were selected representing different kinds of landscape with different patterns. For the IKONOS image the subsets covered a forested area with a golf course, a business area, a residential area, and an agricultural area. The subsets of the SPOT5 image covered a floodplain, a dune area with sparse vegetation where the soil is covered by lichens, a dune area with sparse vegetation but without lichens, and a dune area with many patches without vegetation and without lichens. In total 10x2 images were available for the analysis (8 subsets, 2 full images, original and EPSF). All images were segmented at five different heterogeneity levels.

To quantify the effect of the seed location, the tessellations of the subsets were compared to the tessellation of the full image by overlaying and by analyzing the length of segment borders, both for the original and the EPSF versions. The length of segment borders that coincided between the subset and the full image was divided by the length of all borders in the subset (excluding the enveloping rectangle). The outcome was subtracted from 1 and this value was taken as a measure to quantify the seed effect.

The results show that the segmentation results are more similar between the subset and the full image when the EPSF filter was applied before segmentation. In the heterogeneous area in the Netherlands, the seed effect was on average reduced by 6.6% when applying the EPSF filter. In the more homogenous area in the semi-desert in Kazakhstan, the seed effect was reduced by 48.8%. The seed effect strongly increases with higher heterogeneity levels, for all subsets and for both images.

The explanation for the positive effect of the EPSF filter is likely found in the creation of very small homogenous patches. The seed pixels will be grouped with pixels from the same patch first, which reduces the location effect on the final segmentation.

### 1. INTRODUCTION

Object-based image analysis (OBIA) has grown to a significant approach in remote sensing studies over the past decade (Addink et al., 2012; Blaschke, 2010). Image objects provide a better representation of reality, both in terms of spatial characteristics and of local spectral variation inherent to many landscapes on Earth. A unique step in OBIA is the definition of the objects, which is largely steered by user requirements and the topic of the study. So, while the scene representation is improved when working with objects, a subjective processing step is added. This requires careful consideration of the internal heterogeneity and the shape requirements of the objects to be formed.

When objects are created by a region growing segmentation algorithm, seed locations are selected from which individual segments start growing (Benz et al., 2004). Seed locations are selected randomly but in a fixed pattern, thus ensuring that repeating segmentation of the same image produces an identical tessellation. However, empirical studies show that besides the settings of the segmentation, the relative location of objects to the origin of the image affect the resulting tessellation. When the image that is subjected to the segmentation is changed by adding or removing rows or columns, the resulting segments are not identical anymore. Not at the border of the image as one would expect, but neither in the centre part. Apparently, the exact location of a seed affects the resulting segment. The aim of this study was to find whether the application of an edge-preserving smoothing filter prior to the segmentation will

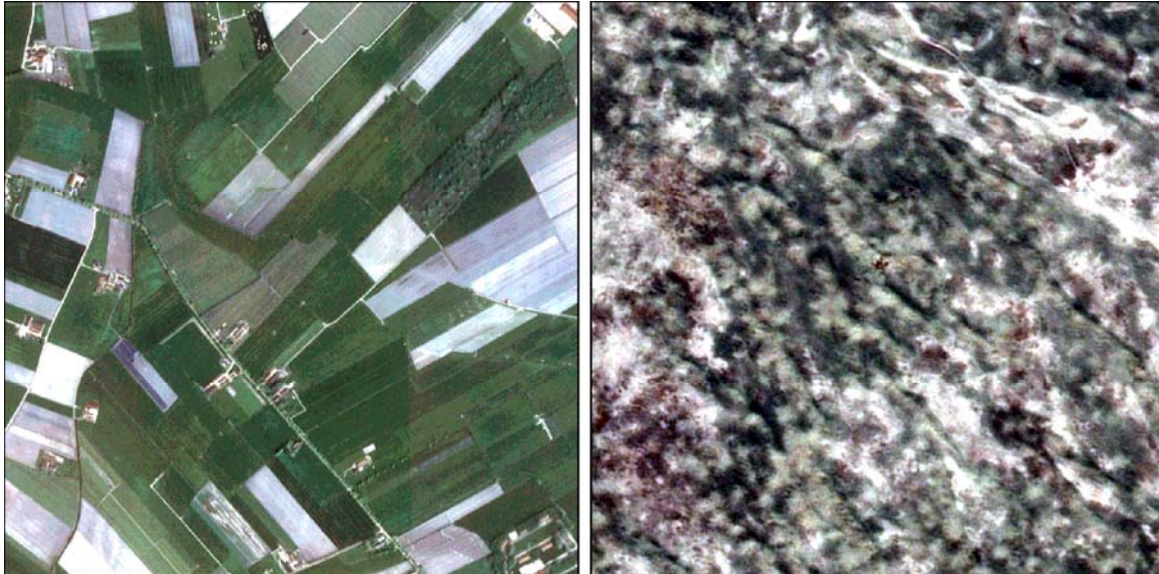

Figure 1. Examples of two subsets from both study areas. Left the agricultural area in the Netherlands (IKONOS image, RGB=RGB). Right the natural semi-desert area in Kazakhstan (SPOT5 image, RGB=NIRRG). The extent of both images is identical in number of pixels.

reduce the random-seed location (RSL) effect. The RSL-effect on image tessellation was first quantified and then calculated on two different images in different landscape settings with different object sizes both with and without an edge-preserving-smoothing filter.

This paper does not intend to identify optimal segmentation results, but rather to investigate if the random seed effect can be reduced by applying an edge preserving smoothing filter and hence make the segmentation of image by random seeds more robust.

## 2. DATA AND METHODS

For this study two images were used: one with strong human influence, and one without human influence (fig 1). The first image is an IKONOS image recorded on 28 April 2000,

featuring a  $10 \times 10 \text{ km}^2$  area just east of the city of Utrecht in The Netherlands. The image comprises four spectral bands with reflectance values in Blue, Green, Red and Near-Infrared and a pixel size of 4m. The reflectance values were stored as integers with bins of 0.25% reflectance. The second image is a SPOT-5 multi-spectral image recorded in October 2010, featuring a  $12 \times 6.5 \text{ km}^2$  area in the PreBalkash region in eastern Kazakhstan. This area is the habitat of the Great Gerbil (*Rhombomys opimus*) that is a host to the vector (fleas) of the bubonic plague. The area is dotted by bright spots which represent the burrow systems of the gerbils (cf Addink et al., 2010). This image comprises three spectral bands with reflectance values in Green, Red and Near\_Infrared and a pixel size of 2.5m. Again, reflectance values were stored as integers with bins of 0.25% reflectance.

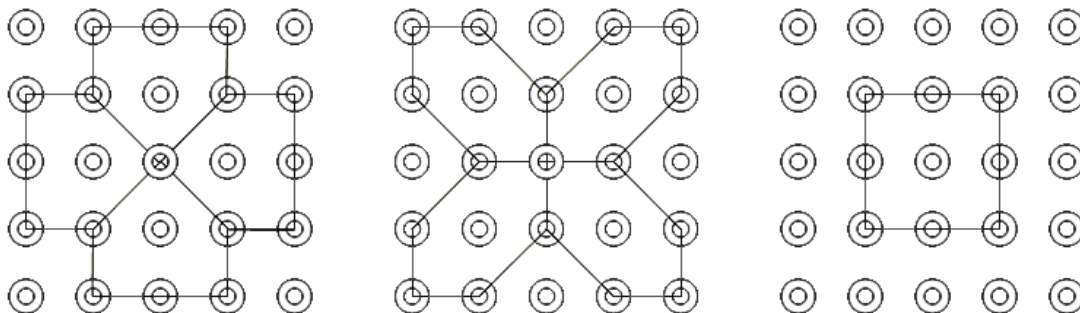

Figure 2. The nine directions for which the Edge Preserving Smoothing Filter calculates total variance.

Both images were subjected to an Edge Preserving Smoothing Filter or EPSF (Nagao & Matsuyama, 1979). The filter was originally designed to prevent blurring of sharp edges and degradation of boundary corners during smoothing. It calculates variance for each band in nine different directions (fig 2) and sums them per direction. The average band values of the direction with the lowest overall variance are then assigned to the central pixel. The filter was applied three times in a row, after which changes in pixel values were negligible. The 'enhanced' edges in the processed images are useful in the segmentation process using random seeds because they stimulate the segmentation algorithms to locate the segment boundaries at similar locations.

To test the effect of the random seed location, subsets were created from both the original and the EPSF-filtered images in order to change the relative position of a pixel to the origin of the image. For both areas four subsets were selected representing different kinds of landscape with different patterns allowing us to test the procedure for different reflectance conditions, for different type of borders and for various types of land cover. For the Ikonos image the subsets measured 2x2km<sup>2</sup>, i.e. 500x500 pixels (fig 1). The subsets represented:

- a forested area with a golf course
- a business area
- a residential area
- an agricultural area.

For the SPOT5 image the subsets measured 1.25x1.25km<sup>2</sup>, i.e. also 500x500 pixels (fig 1). These subsets represented different natural settings:

- a floodplain
- a dune area with sparse vegetation where the soil is covered by lichens
- a dune area with sparse vegetation but without lichens
- a dune area with many patches without vegetation and without lichens

For each area the large images, both original and EPSF-filtered, were segmented at five different heterogeneity levels. A region-growing algorithm was used (Benz et al, 2004).

We continued with two times (Utrecht and Kazakhstan) ten images, of the entire area and of the four subsets both filtered and non-filtered. The images were then segmented at five different heterogeneity levels, so the random-seed effect can also be evaluated against object size (i.e. scale parameter).

To evaluate the effect of the EPSF on the segmentation of the images we used the overlap of the boundaries of the computed segments in the set of images. So, the similarity between the tessellations was defined as the ratio between the summed length of identical object boundaries (in the subset and large images) to the total length of object boundaries within the subset area for both the subset image and the original image. So it is calculated as the average of:

*Sum length identical boundaries/sum length subset image*  
and *Sum length identical boundaries/sum length large image subset area.*

The objects of the subset image are forced to grow inward from the subset boundaries. The length of the outer boundaries of the subsets is therefore not included in the total length of subset image boundaries.

### 3. RESULTS

The similarity between tessellations in the full image and the subset image is highest for smaller objects. Furthermore, the similarity is always higher for the EPSF-filtered images.

Similarities decrease with larger objects. For smallest objects of the Utrecht/IKONOS image similarity values ranged from 95.0 to 98.5%, while the largest objects showed a range of 81.1 to 92.7%. For the Kazakhstan/SPOT5 image similarities ranged from 94.7 to 99.9% for the smallest objects and 77.5 and 91.5% for the largest objects.

Similarities were on average higher when the EPSF was applied than when the original image was segmented. For the Utrecht image differences were relatively small with an average difference of 1.4%, although tessellations of the original and the subset images were more similar for the EPSF images than the original image for scale parameters 10, 20, 30 and 40. For the Kazakhstan image differences averaged at 6.5% and the EPSF similarities always outperformed the original ones.

Original

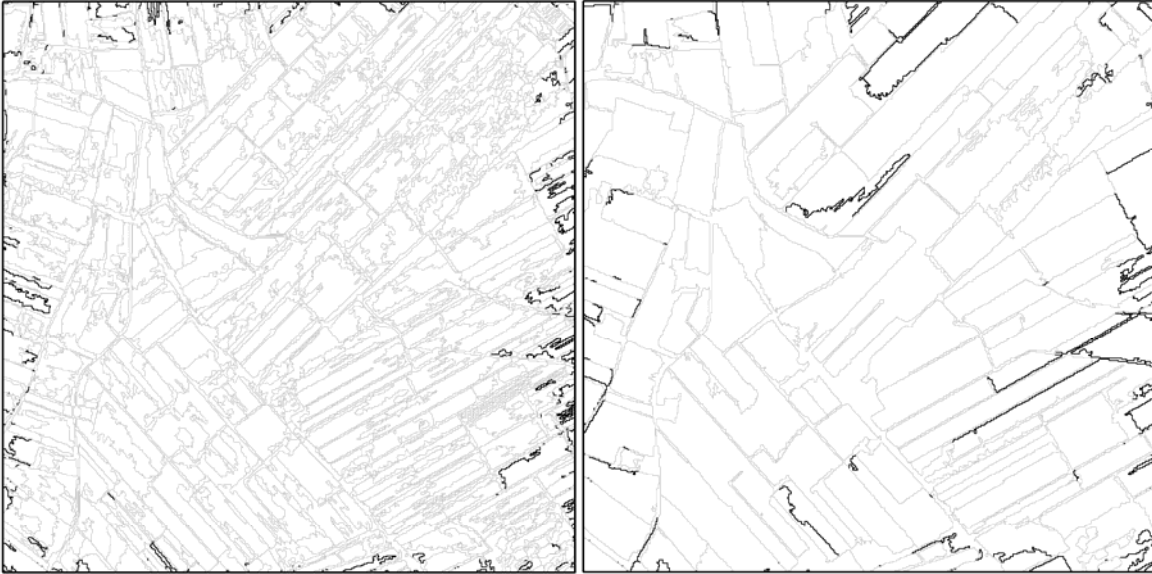

EPSF



0 250 500 1,000  
Meters

Figure 3. The agricultural subset (shown in figure 1) of the IKONOS image segmented with scale parameter 10 (left) and 50 (right). The top row shows the results from the original image, while the bottom row shows the results of the filtered image. Grey lines show coinciding object boundaries, while the black lines show boundaries that changed due to the subsetting.

Original

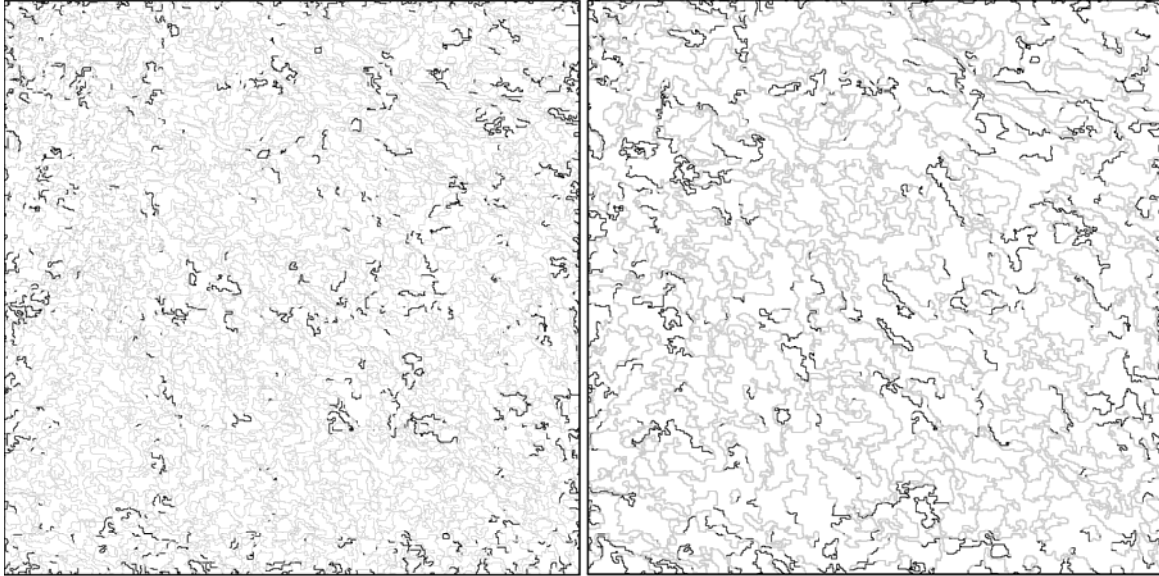

EPSF

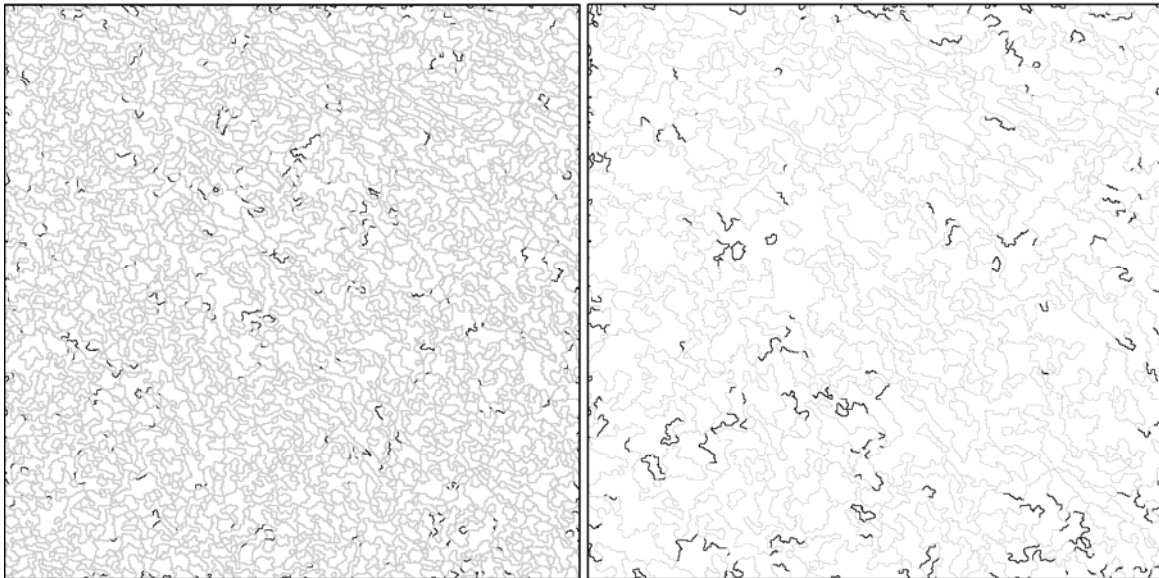

0 250 500 1,000 Meters

Figure 4. The fourth subset (shown in figure 1) of the SPOT5 image segmented with scale parameter 20 (left) and 50 (right). The top row shows the results from the original image, while the bottom row shows the results of the filtered image. Grey lines show coinciding object boundaries, while the black lines show boundaries that changed due to the subsetting.

#### 4. DISCUSSION AND CONCLUSIONS

The results of this analysis show that the effect of the random seed location is reduced when an Edge Preserving Smoothing Filter is applied prior to segmentation. This filter calculates new pixel values by averaging the pixel values of the direction with lowest variance irrespective of the level of this variance. The resulting effect is that small, rather homogenous patches are created in the image before larger objects are created by segmentation.

All eight subsets, in the two areas in the Netherlands and in Kazakhstan, show that higher heterogeneity thresholds result in a decrease in similarity between the objects defined for the entire image and the subset. This is presumably caused by the decrease of the relative distance from an object to the border of the subset. When the subset is segmented, the objects can only be created inward, while this limitation is absent during the segmentation of the full image. Therefore, one expects the objects close to the border to show dissimilarities for the two segmentation results. This is confirmed by the higher densities in figures 3 and 4 close to the borders.

The EPSF does not apply a threshold and hence will calculate new pixel values independent of the local contrast. It could therefore erase very local high-contrast phenomena from the image with a magnitude in the order of one to three pixels, as the new values are calculated over seven to nine pixels.

Once the objects are defined, the original pixel values can be used for the attribute values characterizing them. Therefore, application of the EPSF is believed to enhance the creation of representative objects.

From this study we conclude that the EPSF filtering has a positive effect on the segmentation calculation in high resolution images. The randomness factor of the computation of segments is reduced by applying EPSF before segmentation by the seed approach. The effect is largest near the boundaries of the images and varies from more natural to more cultivated

areas. Based on the results of this study we recommend applying EPSF before segmentation when using high spatial resolution imagery.

#### Acknowledgements

The SPOT5 image was obtained through the ISIS programme of SPOTimage/CNES, number ISIS 395 and ISIS 476. Copyright SPOTimage/CNES.

#### References

- Addink, E. A., Van Coillie, F. M. B. & De Jong, S. M. (2012). Introduction to the GEOBIA 2010 special issue: From pixels to geographic objects in remote sensing image analysis. *International Journal of Applied Earth Observation and Geoinformation*, 15, 1-6.
- Addink, E. A., De Jong, S. M., Davis, S. A., Dubyanskiy, V., Burdelov, L. A. & Leirs, H. (2010a). The use of high-resolution remote sensing for plague surveillance in Kazakhstan. *Remote Sensing of Environment*, 114, 674-681.
- Blaschke, T. (2010b). Object based image analysis for remote sensing. *ISPRS Journal of Photogrammetry and Remote Sensing*, 65(1), 2-16.
- Benz, U. C., Hofmann, P., Willhauck, G., Lingenfelder, I. & Heynen, M. (2004). Multi-resolution, object-oriented fuzzy analysis of remote sensing data for GIS-ready information. *ISPRS Journal of Photogrammetry and Remote Sensing*, 58(3-4), 239-258.
- Nagao, M. & Matsuyama, T. (1979). Edge preserving smoothing. *Computer Graphics and Image Processing*, 9, 394-407.