

---

# Angle discrimination in raised-line drawings

---

Maarten W A Wijtjes, Astrid M L Kappers

Physics of Man, Helmholtz Institute, Utrecht University, Princetonplein 5, NL 3584 CC Utrecht, The Netherlands; e-mail: m.w.a.wijtjes@phys.uu.nl

Received 5 April 2006, in revised form 19 October 2006; published online 23 May 2007

---

**Abstract.** We investigated the angular resolution subserving the haptic perception of raised-line drawings by measuring how accurately observers could discriminate between two angle sizes under various conditions. We found that, for acute angles, discrimination performance is highly dependent on exploration strategy: mean thresholds of  $2.9^\circ$  and  $6.0^\circ$  were found for two different exploration strategies. For one of the strategies we found that discriminability is not dependent on the bisector orientation of the angle. Furthermore, we found that thresholds almost double when the angular extent is increased from  $20^\circ$  to  $135^\circ$ . We also found that local apex information has a significant influence on discrimination for acute as well as obtuse angles. In the last experiment we investigated the influence of depiction mode but did not find any effect. Overall, the results tell us that the acuity with which angles in raised-line drawings are perceived is determined by the exploration strategy, local apex information, and global angular extent.

## 1 Introduction

The vast quantity of visual line drawings used in everyday life indicates that representing a real object with a line drawing conserves the visual recognisability to a large extent. With haptic perception, on the other hand, there is a large difference between recognising real objects and their 2-D raised-line depictions (Klatzky et al 1993). Whereas for the haptic recognition of real objects latencies of a few seconds are typically found (Klatzky et al 1985), latencies can easily last a minute or more in the case of raised-line drawings (Heller 1989; Lederman et al 1990; Magee and Kennedy 1980). One of the causes of these high latencies is the serial nature of spatial-information acquisition by the fingertip. The study by Loomis et al (1991) showed that, if the visual field of view is limited to the effective field of a fingertip, recognition latencies for vision and touch become of comparable length.

Numerous investigators have reported on various aspects of the recognition process, such as the influence of visual status (Heller 1989; Lederman et al 1990), the benefit of categorical information (Heller et al 1996), and the influence of depiction technique (Thompson et al 2003). However, little is known about the perceptual performance subserving this recognition process. To understand the perceptual capabilities of the haptic system, one needs to study both perceptual biases and discrimination ability. The first category of experiments has already received some attention in the literature: Armstrong and Marks (1999) showed that linear extent explored radially tends to be overestimated with respect to tangentially explored lines, and Lakatos and Marks (1998) showed that haptically explored angles consisting either of raised lines or of wooden blocks tend to be overestimated. Furthermore, the subject of haptic illusions has been broadly studied (eg Gentaz and Hatwell 2004; Heller 2002; Millar and Al-Attar 2000, 2002). Although these investigations of perceptual biases are important for our understanding of distortions that occur in line-drawing perception, they do not give any insight into the accuracy with which the haptic system encodes or decodes a stimulus.

Research into haptic spatial acuity relevant for haptic line drawings is confined to the well-known two-point threshold (Weber 1834/1996) and to studies of the limited spatial bandwidth of touch (eg Loomis 1981, 1990). These studies tell us what cutaneous limitations are to be expected and should be taken into account when the perception of raised-line stimuli is studied. Russier (1999) investigated the influence of visual status (blind or sighted) on a person's ability to discriminate circles from ellipses, but this study did not yield quantitative discrimination thresholds.

The main purpose of the study presented here is to provide more insight into the discriminability of the geometric features of raised-line drawings, in particular how well observers can discriminate between two angle sizes. We studied two main factors that could influence angle discrimination: the exploration mode and the geometric properties of the angle, such as bisector orientation and angular extent.

In the first experiment, we investigated the influence of the bisector orientation on the discriminability of the sizes of acute angles around  $20^\circ$ . Movement was restricted to moving the fingertip between the arms of the angle, which means following the imaginary bisector as can be seen in figure 2. In pilot experiments this exploration strategy yielded the lowest discrimination thresholds. During pilot experiments it was also observed that this type of exploration was spontaneously used by subjects who were free to move and received feedback upon their performance.

Cutaneous perception of spatial features such as gratings or gaps has been shown to depend on the orientation with which it is presented to the finger (eg Essock et al 1997; Gibson and Craig 2005; Wheat and Goodwin 2000), although some findings seem to contradict each other [compare Essock et al (1997) with Craig (1999)]. There is not much known about the orientation dependence of more complex shapes such as angles. Investigating orientation dependence could resolve this question and thus contribute to the field of cutaneous shape perception.

In the second experiment we studied the influence that two general geometric properties of an angle have on discriminability: angular extent and apex presence. Instead of using the exploration strategy from experiment 1, we instructed participants to follow the arms of the angle. This strategy is applicable to both acute and obtuse angles. By using the same reference angle for the acute angle condition as we used in the first experiment, thus again measuring discrimination performance around  $20^\circ$ , we could quantitatively compare the two exploration strategies. Research done by Voisin et al (2002a) showed that the 75% correct response threshold for reference angles of  $90^\circ$  consisting of two metal strips is  $4.7^\circ$ . They also found that cutaneous and kinaesthetic input were of equal importance for angle discrimination. In our experiment we used two reference angles and looked at the effect of angular extent. Information about the angular extent can be retrieved from the global line orientations and from the local apex information. The line orientation information is likely to be encoded kinaesthetically (although guidance is always mediated by cutaneous cues) and the local information encoding of the apex is likely to be of a more cutaneous nature. To investigate the contribution of apex information in a discrimination task, we altered its availability by removing the apex in one condition. On the basis of the results of experiment 1 we hypothesised that information from the apex would be particularly helpful for the discrimination of acute angles. The hypothesised result would thus be that discrimination thresholds increase only for acute  $20^\circ$  angles but not for obtuse  $135^\circ$  angles when the apex is removed.

A large effect of angular extent on discriminability was found in the second experiment. To investigate what influence movement direction had on this effect, we conducted a third experiment in which we looked closer at this factor.

---

The fourth experiment was designed to investigate the role of depiction mode, ie the boundaries of raised lines or raised surfaces. The question we want to answer is whether discrimination ability is altered if a raised boundary instead of a raised line is used to constitute the angle. It could be that a raised line is better than a raised-surface boundary at guiding the finger along the arms of an angle, or vice versa. For the raised-surface boundaries we also looked at the effect of touching the edge of the surface on its convex or concave side. Fasse et al (2000) noted that, with virtual shape perception, moving along the inside of an angle is easier than along the outside. This hypothesis is tested by looking at the discriminability of convex and concave angles. Furthermore, research into haptic picture perception showed that pictures consisting of raised surfaces are better recognised than pictures consisting of raised lines (Thompson et al 2003). Finding lower discrimination thresholds for raised-surface-boundary angles could give us a better understanding of the recognition improvement found by Thompson et al (2003).

## 2 Experiment 1

In the first experiment, we investigated whether discrimination performance of angles near  $20^\circ$  depends on the orientation of the bisector. Using the method of constant stimuli, we measured the 84% correct response threshold values. Participants were instructed to follow the imaginary bisector between the two arms of the angle (see figure 2). Since the influence of angle rotation was being investigated, hand movements were restricted to translational motion.

### 2.1 Method

2.1.1 *Participants.* Six participants were reimbursed for their participation. All participants were rated 'strongly right-handed' according to the handedness test of Coren (1993). The participants were naive with respect to the purpose of the experiment and had not participated in a related experiment before.

2.1.2 *Stimuli.* Examples of the stimuli can be found in figure 1. All stimuli were produced with Zytech Swell Paper. The arms of the angles were printed on regular A4 paper. The width of the lines was 1 mm. To prevent participants from using the distance between the endpoints as a cue, the length of each individual line was randomised between 45 and 68 mm. It should be noted that the only purpose of the length manipulation was to avoid the use of improper cues and not to analyse the effect of arm length on angle perception. The printed images were photocopies on Zytech Swell Paper which was treated with a special infrared heating device to emboss the lines. The resulting height of the lines was approximately 0.5 mm.

In all conditions the reference angle was  $20^\circ$ ; the test angles differed from the reference angle by  $\pm (1^\circ, 2^\circ, 3^\circ, 5^\circ)$ . The five bisector orientations were varied between  $0^\circ$  and  $90^\circ$  in steps of  $22.5^\circ$ . The bisector orientation of a stimulus pair was always the same: ie the reference and test angle within a trial had the same orientation.

2.1.3 *Procedure.* In the following, the terms vertical and horizontal are defined as both lying in the horizontal (table) plane, vertical meaning parallel to the observers' midsagittal plane and horizontal meaning parallel to the observers' frontoparallel plane. In order to keep the index finger in the vertical direction, the forearm was fixed to the end of a parallel drawing machine, as can be seen in figure 2. At the location where the drawing compass is normally fixed, a wrist holder was constructed by attaching a modified wrist protector (normally used for skating) to a steel plate. The right hand of the observer was placed in the wrist protector and the tilt of the forearm was adjusted until the fingertip could easily touch the stimulus. The hand movements were videotaped in order to check whether the finger was in an appropriate position.

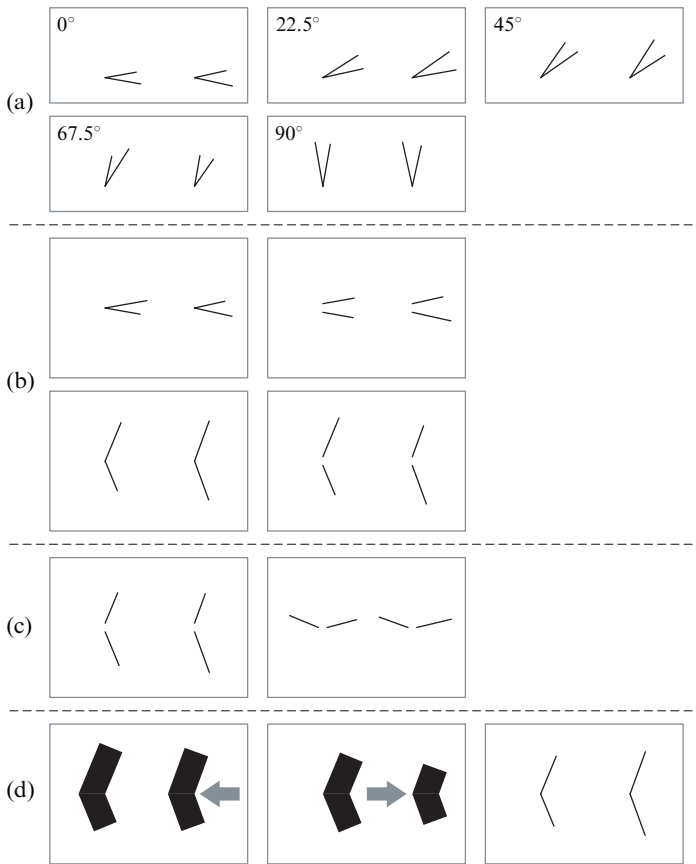

**Figure 1.** Examples of the stimulus sheets. For clarity, the scale of the gap sizes and line width is doubled. In these examples, angles on the left of the sheets are equal to the reference angle and angles on the right are  $5^\circ$  larger. (a) Stimulus sheets used for experiment 1. At the top left the  $0^\circ$  bisect orientation stimulus sheet is depicted, followed by  $22.5^\circ$ ,  $45^\circ$ ,  $67.5^\circ$ , and  $90^\circ$ . (b) The stimuli used for experiment 2. The upper graphs show the  $20^\circ$  angles with and without apex, the lower graphs show the  $135^\circ$  angles. Note that the apices and gaps are located at a fixed position. (c) Stimulus set used for experiment 3. (d) Stimulus set used for experiment 4, from left to right the concave, convex, and line condition. The grey arrows indicate the side at which the stimulus was touched. It should be noted that in this condition too the apices were always in the same position.

Participants were blindfolded and did not receive feedback throughout the experiment. The experimenter placed the stimulus sheet in a stainless-steel mould (see figure 2) which was mounted on the table. Every stimulus sheet contained a reference angle and a test angle. The vertical size of the sheets and mould was 14.3 cm and the apices of the angles were located at a vertical distance of 3.8 cm. The distance between the apices of the two angles was 13.4 cm. The mould was 13.4 cm longer than the length of the stimulus sheet. After the stimulus sheet had been placed on the left side of the mould, the participants started to feel the right angle with their right-hand index finger. The participants were instructed to move their fingertip between the arms of the angle following the imaginary bisector (see figure 2) without losing contact with either of the lines. After moving maximally four times back and forth, participants lifted their right-hand index finger, shifted the stimulus sheet with their left hand to the right and began to feel the left angle. This procedure could be repeated until each angle was felt twice. At the end of such a trial the participant indicated verbally which angle was perceived as larger.

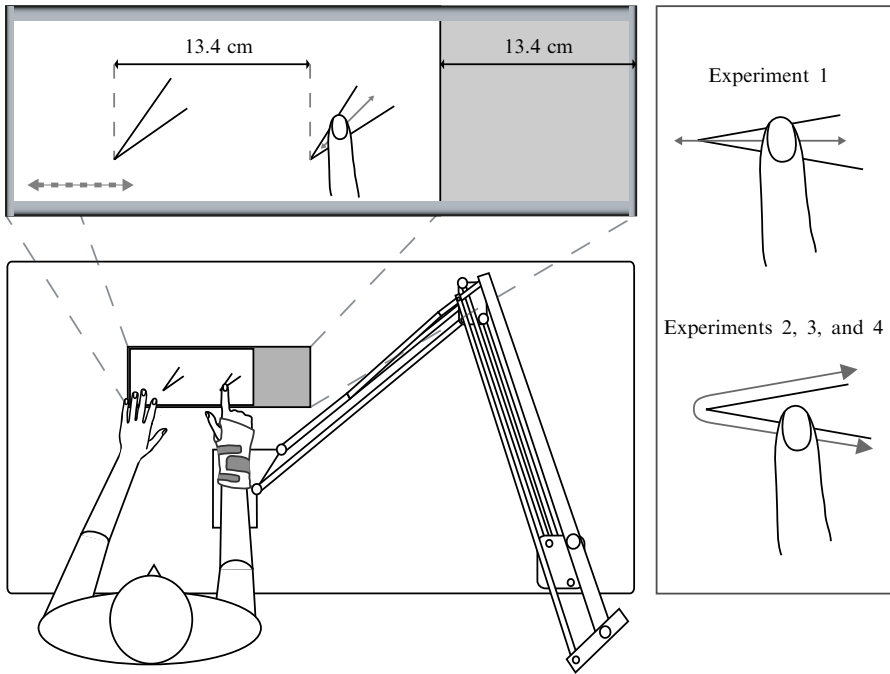

**Figure 2.** A top view of the setup for experiment 1 is presented on the left. Because the parallel drafting machine allows only translational motion, the index finger is always pointing in the vertical direction. At the start of each trial, the stimulus sheet was placed on the left-hand side as depicted. In the magnification inset of the mould, the dashed arrow indicates the movement of the sheet controlled by the left hand when the stimuli had to be switched; the arrow under the finger indicates the movement of the fingertip following the imaginary bisect. A sketch of the two exploration movements is presented on the right.

The different bisector orientations were presented randomly and were balanced within a session which consisted of 80 trials. Each bisector orientation set consisted of 8 different test angles which were presented 10 times each, except for the  $45^\circ$  and  $90^\circ$  orientations which were presented 20 times. This resulted in a total number of 560 trials per subject spread out over 5 sessions of approximately 1 h. For each test and reference stimulus pair, two stimulus sheets were fabricated, one with the reference angle on the left and one on the right. The reference stimulus was presented equally often on the left and on the right.

Observing the videotapes of the first three participants suggested that the hand orientations of the participants might have systematically deviated from vertical. To prevent further biases, the last three participants were equipped with an extra hand-fixation kit: a material normally used in physiotherapy was used to fabricate fixation gloves around the wrist and lower phalanx of the right-hand index finger. This fixation glove could be worn between the hand and the modified wrist protector.

The collected two-alternative forced choice (2AFC) responses were transformed into fractions of the number of times that the test angle was judged to be larger than the reference angle. The psychometric function to which the data were fitted was chosen to be the (normalised) cumulative Gauss distribution which can be written as:

$$f(\alpha, \sigma, \mu) = \frac{1}{\sigma\sqrt{2\pi}} \int_{-\infty}^{\alpha} \exp\left[-\frac{(\alpha' - \mu)^2}{2\sigma^2}\right] d\alpha', \quad (1)$$

where  $\alpha$  denotes the test angle and  $\mu$  the point of subjective equality (PSE). Since the stimulus set was completely counterbalanced, we fitted only the threshold value  $\sigma$  and not

the PSE  $\mu$ . The discrimination threshold at 84% correct<sup>(1)</sup> is defined by the parameter  $\sigma$  since  $f(\sigma, \sigma, 0) = 1 - f(-\sigma, \sigma, 0) \simeq 0.84$ .

A one-way repeated-measures design with bisector orientation as factor was used to analyse the effect of orientation on discriminability.

An estimate of the variability of the fitted threshold parameters was determined by the bootstrap method described by Wichmann and Hill (2001). From the stimulus set interval, the number of trials per test stimulus, and the measured threshold value as initial conditions we calculated a set of  $N = 10\,000$  simulated threshold values. From this distribution we calculated the 95% confidence interval.

To investigate whether participants showed a learning effect, we analysed changes in performance between the first and second half of the experiment. We did this by collapsing the data of all conditions per participant and split this into a first and second half. We then calculated the threshold values for these two data sets and used paired  $t$ -tests to investigate whether the discrimination performance was different between the first and second half of the experiment.

## 2.2 Results

Individual thresholds as a function of bisector orientation are presented in figure 3. Visual inspection does not reveal a general effect of orientation on discrimination performance. This is confirmed by a repeated-measures analysis of variance (ANOVA) which shows that the influence of the bisector orientation on discrimination thresholds is not significant ( $F_{4,20} = 2.764$ ,  $p = 0.056$ ). The average discrimination threshold for all directions and participants is  $2.9^\circ$ . An ANOVA with the participants as independent variable revealed that there was no significant difference between their performances ( $F_{5,24} = 1.615$ ,  $p = 0.194$ ). The 95% confidence interval of a  $2.9^\circ$  threshold value was calculated to be  $[1.9^\circ, 4.2^\circ]$ . All threshold values are within the 95% confidence interval of the mean threshold. This indicates that the within-participants fluctuations are probably due to chance. So there is no general trend for all participants, nor has any significant idiosyncratic behaviour been found. Also, no learning effect was found.

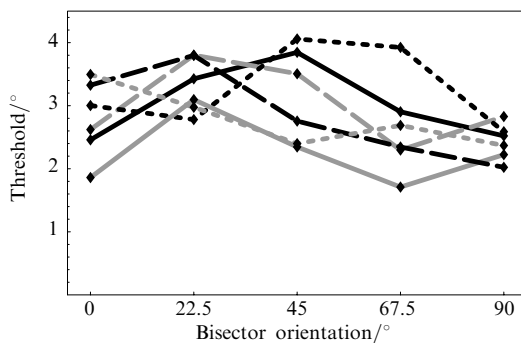

**Figure 3.** Threshold values as a function of bisector orientation for all six participants in experiment 1.

<sup>(1)</sup>The 84% level of the Gaussian cumulative distribution is comparable to the 68% level of the Gaussian probability density, both described by the standard deviation parameter  $\sigma$ . But whereas 68% is described by the integral of the Gaussian between  $[-\sigma, \sigma]$ , 84% results if we include one 'tail' of the Gaussian by integrating between  $[-\infty, \sigma]$ . In detection experiments often a threshold of 75% correct is reported. The conversion factor between 75% and 84% is slightly dependent on the description of the sigmoid used for fitting and is, in case of a cumulative Gaussian, approximately 1.48. It may seem counterintuitive, but the ratios of two threshold values described by two different parameters, is independent of the level set. This means that for the statistical analyses it does not matter which level is used.

---

### 2.3 Discussion

The variation of thresholds between different directions and participants seems to fall within a well-defined range of  $2^\circ$  to  $4^\circ$ . This indicates that the strategy whereby the fingertip follows the bisector yields a robust discrimination performance. This is confirmed by the absence of significantly different performances across participants.

## 3 Experiment 2

A second experiment was designed to measure the discrimination performance for both acute and obtuse angles. To enable us to make comparisons with experiment 1 we chose the angle of reference for the acute angles to be  $20^\circ$ ; the angle of reference for the obtuse angles was  $135^\circ$ . Angular extent and presence of the apex were both independent variables. Differential use of the local apex information could account for possible differences between the discrimination of acute and obtuse angles. Participants were instructed to follow the arms of the angles for the exploration of the angles.

The two exploration strategies differ with regard to the simultaneous contact with the two lines. Although to a lesser extent than with the first strategy, there is still simultaneous contact of the fingertip with the two lines with the second strategy. This is caused by the fingertip moving along one arm and already touching the other line while approaching the apex and thus feeling how fast the lines are converging and diverging. The amount of simultaneous contact obviously decreases with increasing angular extent. If this phase of the exploratory trajectory is to be beneficial for discrimination, then the removal of the apex will particularly influence the discriminability of acute angles. Thus we hypothesise that removing the apex will mainly have an effect on the discriminability of the  $20^\circ$  angle.

### 3.1 Method

**3.1.1 Participants.** Eight strongly right-handed (Coren 1993) participants were reimbursed for their participation. The participants were naive with respect to the purpose of the experiment and had not participated in a previous, related experiment.

**3.1.2 Stimuli.** The stimuli, which can be seen in figure 1, were produced in the same way as in experiment 1. The same length randomisation was applied as in the first experiment. The size of the reference angle was either  $20^\circ$  or  $135^\circ$  and the bisector orientation was fixed at  $0^\circ$  with respect to the horizontal. The gap caused by cutting off the apex was chosen not to exceed the contact area of the exploring finger because this would generate extra path-following difficulties during exploration. Contact-area measurements during pilot experiments indicated that a gap size of 6.5 mm should be well within the range of average fingertip contact area. The gap size was independent of the angle size. The vertical size of the sheets and mould were 21 cm and the apices of the angles were located at a vertical distance of 10.5 cm. As in the first experiment, the two angles were printed 13.4 cm apart. Pilot experiments indicated that different thresholds across different conditions could be expected. The sets of test stimuli were adjusted accordingly; the range of test angles was larger for larger predicted discrimination thresholds. An overview of different test stimulus sets per condition can be found in table 1.

**3.1.3 Procedure.** In all the following experiments the observers were free to move, ie no movement-restricting apparatus was used. The exploration of the angle was described in the following way: the arms of the angle were to be followed with the index finger of the preferred hand (see figure 2). Subjects were allowed to move the finger maximally twice back and forth along the complete angle path. The starting point could be chosen freely, but during instructions the observers learned to use the apex or the gap as a starting point. Each angle could be felt not more than twice. Thus, if we assign

**Table 1.** Overview of the angular differences between test and reference angles for experiment 2. The asterisk denotes the set used for the last three participants.

Apex condition	Reference angle/°	
	20°	135°
Without gap	± (2, 4, 6, 8, 10) ± (5, 10, 15, 20, 25, 30)*	± (2, 4, 6, 8, 10, 14)
With gap	± (3, 6, 9, 12, 15) ± (6, 12, 18, 24, 30, 36)*	± (3, 6, 9, 12, 15, 20)

$a$  to the apex location and  $b$  and  $c$  to the locations of the endpoints, the maximum movement permitted is described by *abacabaca*. The switching procedure between test and reference stimulus which involved shifting the stimulus sheet was the same as in the first experiment. Before the start of the experiment, a training period including not more than 6 randomly chosen stimuli allowed the participants to become familiar with the procedure and the stimuli. No feedback was given during the training or the experiment.

Participants were presented with all of the acute-angle stimuli (reference 20°) with randomly assigned gap conditions, followed by all the obtuse-angle stimuli (reference 135°). Possible order effects influencing the data will be commented on in the discussion. In the 20° reference block, the sampling set consisted of  $d = 10$  different test stimuli which were presented  $N = 12$  times, and in the 135° reference block, the sampling set consisted of  $d = 12$  different test stimuli which were presented  $N = 10$  times. As in the first experiment, test and reference angles were presented an equal number of times to be felt first. For each participant, 480 trials ( $N \times d \times$  conditions) were distributed over 6 sessions of approximately 1 h.

The experiment was a within-subjects design with repeated measures taken on the apex presence (present, absent) and the angular extent (20°, 135°).

### 3.2 Results

The 84% correct response thresholds defined by the best-fit parameter  $\sigma$  from equation (1) are plotted in figure 4. A repeated-measures two-way ANOVA reveals that both the presence of the apex ( $F_{1,7} = 9.893$ ,  $p = 0.016$ ) and the angular extent ( $F_{1,7} = 19.307$ ,  $p = 0.003$ ) have a significant influence on discrimination performance. There is no significant interaction between the two conditions ( $F_{1,7} = 2.383$ ,  $p = 0.167$ ). As can be seen in figure 4c, the thresholds almost double from 20° to 135°, independently of the apex condition. Visual inspection of figure 4 shows that the effect of apex information has a more idiosyncratic influence on the discrimination of 135° angles than that of 20° angles. Table 2 lists all mean thresholds, standard deviations, and the quotients of variation (standard deviation divided by the mean) of all experiments. It can be seen that the relative variation of the 135° with gap condition is much larger than for other conditions. Removing the apex increased the discrimination thresholds for both the acute and the obtuse angles. The learning-effect analysis was done similarly to experiment 1 and was performed on the 20° and 135° data sets separately. In neither of these sets we found significant learning effects.

In order to compare the different exploratory procedures used in the first and second experiments, two groups were compared: the first group consisted of thresholds of the six participants from experiment 1 for the 0° bisector orientation condition; the second group consisted of data drawn from the 20° reference angle with apex thresholds from the second experiment. The mean thresholds were 2.8° for the 'bisector-following' procedure and 6.0° for the 'arm-following' procedure. An unrelated  $t$ -test



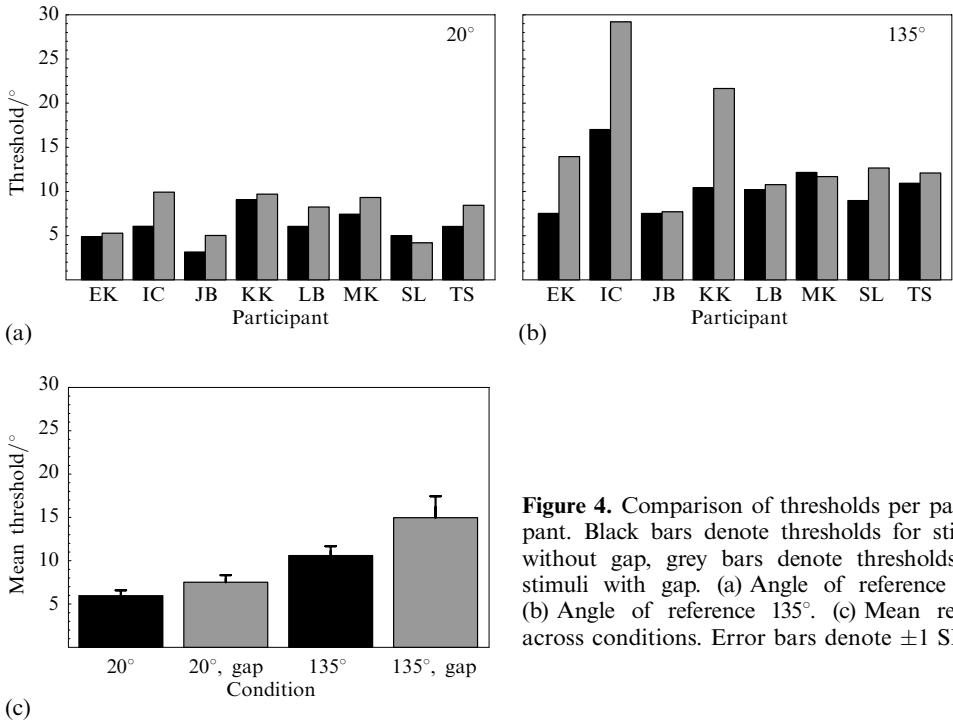

**Figure 4.** Comparison of thresholds per participant. Black bars denote thresholds for stimuli without gap, grey bars denote thresholds for stimuli with gap. (a) Angle of reference 20°. (b) Angle of reference 135°. (c) Mean results across conditions. Error bars denote  $\pm 1$  SE.

**Table 2.** Mean thresholds for each experiment per condition. For the first experiment the average was taken over all conditions and participants. The conditions 135° apex, 135° bisect 0°, and 135° line are identical. The quotient of variation is the standard deviation divided by the mean.

Experiment	Condition	Mean	Standard deviation	Quotient of variation
1	20° bisect	2.87°	0.64°	0.22
2	20° apex	5.96°	1.76°	0.30
	20° gap	7.52°	2.31°	0.31
	135° apex	10.59°	3.06°	0.29
3	135° gap	14.97°	7.00°	0.47
	135° bisect 0°	9.26°	3.43°	0.37
4	135° bisect 90°	11.88°	4.52°	0.38
	135° concave	11.27°	3.69°	0.33
	135° convex	12.39°	4.63°	0.37
	135° line	10.24°	4.76°	0.46

for unequal group sizes showed a significant difference ( $t = 4.985, p < 0.001$ ) between the discrimination of 20° angles depending on whether the ‘arm-following’ procedure or the ‘bisector-following’ procedure was used.

### 3.3 Discussion

Since no learning effects were found and the threshold for the 135° without gap condition was reproduced fairly well in experiments 3 and 4 (see table 2), there is no reason to assume that order effects would be responsible for the difference between the 20° and 135° thresholds.

Both the angular extent and the presence of local apex information influence the discriminability significantly. We controlled the local apex information as an independent variable in this experiment because we predicted that the apex would be of particular

importance for discriminating acute angles but not for obtuse angles. If our assumption was correct, then a different use of the apex would explain why obtuse angles are more difficult to discriminate than acute angles. Since this hypothesis has been disproved, we need to find other explanations for the large effect of angular extent on discriminability. For acute and obtuse angles the average path length is equal and the only geometric difference is that the distance between the midpoints of lines is larger for obtuse angles than for acute angles. It could thus be that the encoding of an angle is more efficient if the lines are close to each other. Before continuing this line of reasoning, we need to be certain that there are no other differences between the acute and obtuse angle conditions. One experimental difference is the average movement direction used for the exploration. To analyse this difference we conducted a third experiment.

#### 4 Experiment 3

In experiment 2 there was an uncontrolled factor between the small and large angles which had to be ruled out as a cause of discrimination differences: average movement direction. Since the exploration procedure in experiment 2 is different from that of experiment 1 we do not know whether the same movement-direction independence holds for the 'arm-following' mode. The movement for the  $20^\circ$  stimuli can be characterised as being more horizontal than that for  $135^\circ$  stimuli. Although unlikely, it is possible that the use of horizontal movement yields higher acuity than the use of vertical movement. To address this issue, experiment 3 was performed.

The horizontal movement employed for the  $20^\circ$  in the previous experiment can be simulated by the rotation of a  $135^\circ$  stimulus. By looking at the effect of a  $90^\circ$  counterclockwise rotated  $135^\circ$  stimulus with respect to a non-rotated one, we isolate the direction of exploration movement as an independent variable.

##### 4.1 Method

Four observers participated in the third experiment, all of whom had participated in the second experiment. We used the  $135^\circ$  angle with gap stimuli and compared this with the same stimuli rotated  $90^\circ$  counterclockwise. The two conditions can be seen in figure 1c. The stimuli were presented in 24-trial blocks with the same bisector orientation condition. The test stimulus set consisted of 12 angles distributed symmetrically and equidistantly around the reference angle. The stimulus set was designed individually for each participant on the assumption that the thresholds measured in experiment 2 would be reproduced approximately. Each test angle was presented 10 times. The bisector orientation of the first block was counterbalanced among the participants. The total number of trials per subject was 240; these were distributed over three sessions of approximately 1 h. The same procedure and data analysis were used as in the second experiment.

##### 4.2 Results and discussion

The results for the four participants are presented in figure 5. For each subject the first two bars show the results of experiment 2, and the second two bars show the results of experiment 3. The first bar denotes the threshold found for the  $20^\circ$  condition and the second bar the threshold for the  $135^\circ$  condition, both from experiment 2. The third bar denotes the threshold for the rotated  $135^\circ$  condition and the fourth bar for the non-rotated  $135^\circ$  condition. The first and third bars thus denote thresholds found for horizontal movement and the second and fourth bars for vertical movement. The second and fourth bars originate from the same condition, which shows that three out of the four subjects performed better the second time for the non-rotated  $135^\circ$  condition. Half of the subjects performed better for the rotated  $135^\circ$  condition in experiment 3 than for the non-rotated  $135^\circ$  condition in experiment 2.

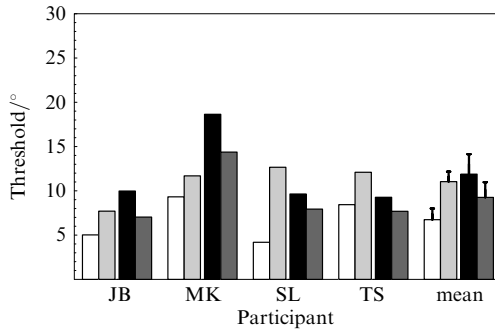

**Figure 5.** Comparison of thresholds per subject of experiment 3. The first two bars are results from experiment 2: from left to right the bars indicate the with-gap conditions for  $20^\circ$  and  $135^\circ$  respectively. Of the second two bars, the first (black) denotes the result for the rotated  $135^\circ$  stimulus and the second (dark grey) denotes the non-rotated  $135^\circ$  stimulus. Movement direction for the first and third bars is more horizontal and for the second and fourth bars more vertical.

It can be clearly seen that rotating the angle does not lead to improvement in discrimination. There would be discrimination improvement if the third bar were lower than the fourth, ie if horizontal movement reduced the discrimination thresholds. The contrary seems to be the case: for all participants the threshold for the  $0^\circ$  bisector orientation is lowest. Since only four subjects participated in this experiment it would be inappropriate to use a statistical test for further interpretation.

## 5 Experiment 4

In the fourth experiment we investigated the influence of angle-depiction mode. The first objective was to measure whether discrimination performance changes when the angle is depicted by a raised-surface boundary instead of a raised line. The second objective was to measure whether there is a difference between feeling concave and convex surface boundary angles. For an explanation of how concavity and convexity are defined, figure 1d should be inspected. As can be seen, 'convex' and 'concave' are defined with respect to the not-embossed white area.

The reference angle was chosen to be  $135^\circ$  in order to allow comparison with previous experiments.

### 5.1 Method

**5.1.1 Participants.** Eight participants who had no experience with the experimental design and were naive with respect to the purpose of the experiment were reimbursed for their time. Seven were strongly right-handed and one (SH) was moderately left-handed (Coren 1993).

**5.1.2 Stimuli.** The stimulus set, which can be seen in figure 1d, was produced in roughly the same way as the sets used for previous experiments. The raised surfaces consisted of 4-cm-wide lines. On all stimulus sheets, the location of apices was independent of angular extent. The ends of the wide lines constituting the surfaces were cut off perpendicularly. The average path length over which the angles were explored was independent of the three conditions and was equal to that of the stimuli used earlier, ie the arm lengths were randomised in the interval between 45 and 68 mm.

**5.1.3 Procedure.** The setup was the same as that used in experiments 2 and 3 and participants were given the same instructions. The three different conditions were presented in blocks of 24 trials. The order of presentation was semi-randomly assigned to the participants so as to balance the starting condition. The sampling intervals were the same for all conditions and consisted of 12 different test angles that were distributed

around the  $135^\circ$  reference angle  $\pm (4^\circ, 8^\circ, 12^\circ, 16^\circ, 20^\circ, 24^\circ)$ . Each reference angle was presented 10 times, balanced for test and reference order. This resulted in a total of 360 trials distributed over four to five sessions of 1 h. Each threshold value per depiction mode and participant was thus calculated from a psychometric curve fitted to 120 trials. The experiment was a one-factor (depiction mode) design with repeated measures on the participants.

The stimuli were presented in the same orientation for all participants. The only difference for the left-handed participant (SH) was that in his case the stimulus sheet was presented on the right, but the orientation of the angles was the same for him as for the other participants.

## 5.2 Results and discussion

The threshold values for all participants are presented in figure 6. As can be seen, participants do not show consistent discrimination performance for the three conditions. A one-way repeated-measures ANOVA confirms the absence of main effects ( $F_{2,14} = 1.257, p = 0.315$ ). The average threshold value for the raised-line condition of  $10.2^\circ$  is comparable to the threshold of  $10.6^\circ$  for the without-gap condition from experiment 2. Furthermore, no learning effect was found. As was found previously, there are large discrimination differences within and between participants. Table 2 gives an overview of all mean thresholds for all experiments. The results show that the depiction mode does not have an influence on angular acuity. Introspective reports collected after the experiment also indicated that there was not a strong preference for any one of the conditions.

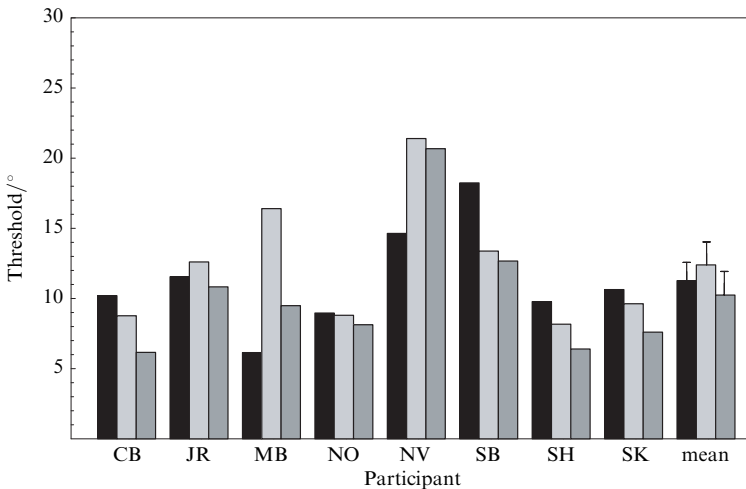

**Figure 6.** Thresholds per subject for the conditions ‘concave’, ‘convex’, and ‘line’ from left to right. The ninth bar trio represents the results per condition averaged over the participants.

## 6 General discussion

We investigated what factors influence angular acuity in raised-line drawings. First, we found that movement direction did not influence discriminability in experiment 1. Furthermore, we found that exploration strategy, angular extent, and the apex have a significant influence on discrimination ability. We will now discuss how these results can be interpreted.

In the first experiment, no directional influence on discrimination performance was found for bisector orientations between  $0^\circ$  and  $90^\circ$ . The apparent independence from movement direction, the non-significant difference between participants, and the low relative variation (see table 2) show that the discrimination threshold values are fairly robust. It is thus likely that participants used the same cues or mental strategy to perform the discrimination task. We already mentioned in the introduction that the

---

primary motivation of varying orientation was to investigate whether cutaneous angular information also showed anisotropic behaviour as have other studies shown for the cutaneous sense (eg Essock et al 1997; Gibson and Craig 2005; Wheat and Goodwin 2000). Although we did not find orientation dependence, we should justify whether the spatial information is indeed cutaneous before we can start comparing the results between the first and the second experiment. It is possible to acquire kinaesthetic information about the angular extent from the path length followed by the finger from the apex until the fingerpad loses contact with the lines, ie where the distance between the lines equals the effective diameter of the contact area. This distance scales with the cotangent of the angle and could thus be used to discriminate angles. From our data we cannot be completely sure whether participants used this kinaesthetic information source. However, looking at the video recordings, which were made to check whether the orientation of the finger stayed constant during the experiment, revealed that participants did not use this strategy systematically. For five participants it was observed that the finger largely overshoots the above-defined endpoint for angles in the  $90^\circ$  orientation. For the other orientations, it could not always be seen clearly owing to viewpoint limitations. These observations, though not quantified objectively, led us to assume that the spatial information used for the first strategy is cutaneous.

Comparison between experiments 1 and 2 showed that exploration strategy has a marked influence on discrimination performance. Moving the fingertip between the arms of an angle yields discrimination thresholds which are half those for angles explored by following the lines. That exploration strategy can influence haptic perceptual performance has been found previously by Davidson (1972). He showed that curvature perception was more veridical for blind than for sighted observers. However, he also observed that multiple exploration strategies were spontaneously used and that blind observers used a certain strategy ('grip') markedly more often than the sighted observers. In a subsequent experiment the superiority of this strategy was confirmed. Also, in tactile map research it has been shown that some aspects of spontaneous exploration, such as line following and shape distinction, predict the quality of the map reader (Berla et al 1976). Furthermore, it has been found that, in general, humans use a variety of spontaneous exploratory procedures in order to perceive various 3-D object properties (Lederman and Klatzky 1987). These findings illustrate a difficulty which haptic scientists often encounter: how to control for the information input when subjects explore stimuli in different ways? Evidently it is important, when conducting haptic psychophysics, to restrict or at least register the manual exploration in order to properly relate the stimulus with the perceptual judgment. These findings can furthermore have implications for studies of the perception of raised-line drawings: if there are different exploration modes that are best for the assessment of different geometric features, it could be useful to instruct observers to use those particular modes. In tactile map reading, it has already been shown that training of exploration improves map-reading qualities (Berla and Butterfield 1977).

The second experiment showed that both angular extent and the presence of the apex influence discriminability significantly. Our results do not explain why large angles are more difficult to discriminate than small angles, although experiment 2 and experiment 3 show that both the information from the apex and the average movement direction cannot account for this effect. Since angular extent is a periodic measure, we did not expect that Weber's law (Weber 1834/1996), which states that the fraction of threshold and intensity is constant for different intensities, would apply to our data. This was in line with our data: Weber fractions for  $20^\circ$  and  $135^\circ$  angles were 0.30 and 0.08, respectively.

Introspective reports of the participants revealed another difference between the acute and obtuse angles: the  $135^\circ$  angles were sometimes perceived as being curved,

but not having a well-defined value. More research on this topic is certainly needed, since not only does it give insight into fundamental processes of haptic perception, it could also be of importance for research into the distorted perception of raised-line drawings.

The influence of the apex was not what we had hypothesised. Not only does the presence of the apex influence discrimination for acute angles, but it also influences discrimination for obtuse angles. In both the acute and the obtuse angle conditions, seven out of eight participants showed higher discrimination thresholds for angles without an apex.

As mentioned in the introduction, there has already been research into haptic angle discrimination. Voisin et al (2002a) investigated haptic discrimination ability of a  $90^\circ$  angle made of two metal strips. They found a mean threshold for 75%-correct responses of  $4.7^\circ$  corresponding to an 84% threshold of  $7.0^\circ$ . Even though the study of Voisin et al (2002a) made use of different stimulus material and restricted movement by allowing only shoulder-joint movement, it is remarkable that the  $7.0^\circ$  thresholds for a  $90^\circ$  angle are well within the range of thresholds of  $6.0^\circ$  and  $10.6^\circ$  for our raised-line angles of  $20^\circ$  and  $135^\circ$ , respectively. In our accompanying study, Voisin et al (2002b) showed that kinaesthetic and cutaneous information contributed equally to discrimination ability. This could also hold for our results if we interpret the apex primarily as a cutaneous information source and the movement along the angle arms as kinaesthetic information. Coming back to the comparison of the two exploration strategies, this implies that a strategy purely dependent on cutaneous input (experiment 1) yields thresholds half those of a strategy which uses both cutaneous and kinaesthetic information (experiment 2). This counterintuitive notion points out that combining sensory input does not always yield higher accuracy if multiple exploration strategies are considered.

The fact that we only investigated discrimination performance for two reference angles leaves some interesting questions unanswered. What kind of behaviour will be revealed when a wide range of reference stimuli is mapped onto discrimination performance? The inherent periodicity of the angles predicts at least nonlinear behaviour. Furthermore, in some cases discrimination performance could be influenced by cues such as the alignment of one of the angle arms with body midline. Future research should address these issues.

The last experiment showed that whether an angle is formed from a raised-surface boundary or from raised lines does not influence the discriminability. Fasse et al (2000) noticed that moving inside a virtual rectangle was easier than moving along its outside edge. They did not actually test this hypothesis experimentally; it is based on the hypothesis that moving along the inside of a corner yields a more stable mechanical situation which benefits haptic spatial perception. If these stability matters would also hold for raised-surface boundaries instead of impenetrable 'walls', then concave angles would yield lower discrimination thresholds than convex angles. Thus we cannot conclude from these experiments that the recognition improvement found by Thompson et al (2003) for raised-surface drawings is caused by a higher angular acuity evoked by the nature of the depiction mode.

Our results show that it might be interesting to study in greater depth the exploratory behaviour of raised-line stimuli. Knowledge of what exploration strategy fits which geometric feature, and training persons to use this knowledge, would be helpful to the visually impaired who use tactile pictures in everyday life. The effect of increasing thresholds with increasing angular extent is also worth investigating further. If we could understand what geometric properties influence the mental load of spatial information, we would be in a much better position to understand why the haptic recognition of raised-line drawings is so difficult.

**Acknowledgment.** This research was supported by a grant from the Netherlands Organisation for Scientific Research (NWO).

## References

- Armstrong L, Marks L E, 1999 "Haptic perception of linear extent" *Perception & Psychophysics* **61** 1211–1226
- Berla E, Butterfield L, 1977 "Tactual distinctive features analysis: training blind students in shape recognition and in locating shapes on a map" *Journal of Special Education* **11** 335–345
- Berla E, Butterfield L, Murr M, 1976 "Tactual reading of political maps by blind students: a video-matic behavioral analysis" *Journal of Special Education* **10** 265–276
- Coren S, 1993 *The Left-hander Syndrome: The Causes and Consequences of Left-handedness* (New York: Vintage Books)
- Craig J C, 1999 "Grating orientation as a measure of tactile spatial acuity" *Somatosensory and Motor Research* **16** 197–206
- Davidson P, 1972 "Haptic judgements of curvature by blind and sighted humans" *Journal of Experimental Psychology* **93** 43–55
- Essock E A, Krebs W K, Prather J R, 1997 "Superior sensitivity for tactile stimuli oriented proximally–distally on the finger: Implications for mixed Class 1 and Class 2 anisotropies" *Journal of Experimental Psychology: Human Perception and Performance* **23** 515–527
- Fasse E D, Hogan N, Kay B A, Mussa-Ivaldi F A, 2000 "Haptic interaction with virtual objects—spatial perception and motor control" *Biological Cybernetics* **82** 69–83
- Gentaz E, Hatwell Y, 2004 "Geometrical haptic illusions: The role of exploration in the Müller-Lyer, vertical–horizontal, and Delboeuf illusions" *Psychonomic Bulletin & Review* **11** 31–40
- Gibson G O, Craig J C, 2005 "Tactile spatial sensitivity and anisotropy" *Perception & Psychophysics* **67** 1061–1079
- Heller M A, 1989 "Picture and pattern perception in the sighted and the blind: the advantage of the late blind" *Perception* **18** 379–389
- Heller M A, 2002 "Tactile picture perception in sighted and blind people" *Behavioural Brain Research* **135** 65–68
- Heller M A, Calcaterra J A, Burson L L, Tyler L A, 1996 "Tactual picture identification by blind and sighted people: Effects of providing categorical information" *Perception & Psychophysics* **58** 310–323
- Klatzky R, Lederman S, Metzger V, 1985 "Identifying objects by touch: An expert system" *Perception & Psychophysics* **37** 299–302
- Klatzky R, Loomis J M, Lederman S J, Wake H, Fujita N, 1993 "Haptic identification of objects and their depictions" *Perception & Psychophysics* **54** 170–178
- Lakatos S, Marks L E, 1998 "Haptic underestimation of angular extent" *Perception* **27** 737–754
- Lederman S J, Klatzky R L, 1987 "Hand movements: A window into haptic object recognition" *Cognitive Psychology* **19** 342–368
- Lederman S J, Klatzky R L, Chataway C, Summers C D, 1990 "Visual mediation and the haptic recognition of 2-dimensional pictures of common objects" *Perception & Psychophysics* **47** 54–64
- Loomis J M, 1981 "Tactile pattern perception" *Perception* **10** 5–27
- Loomis J M, 1990 "A model of character-recognition and legibility" *Journal of Experimental Psychology: Human Perception and Performance* **16** 106–120
- Loomis J M, Klatzky R L, Lederman S J, 1991 "Similarity of tactual and visual picture recognition with limited field of view" *Perception* **20** 167–177
- Magee L, Kennedy J, 1980 "Exploring pictures tactually" *Nature* **283** 287–288
- Millar S, Al-Attar Z, 2000 "Vertical and bisection bias in active touch" *Perception* **29** 481–500
- Millar S, Al-Attar Z, 2002 "The Müller-Lyer illusion in touch and vision: Implications for multi-sensory processes" *Perception & Psychophysics* **64** 353–365
- Russier S, 1999 "Haptic discrimination of two dimensional raised-line shapes by blind and sighted adults" *Journal of Visual Impairment & Blindness* **93** 421–426
- Thompson L J, Chronicle E P, Collins A F, 2003 "The role of pictorial convention in haptic picture perception" *Perception* **32** 887–893
- Voisin J, Benoit G V, Chapman C E, 2002a "Haptic discrimination of object shape in humans: two-dimensional angle discrimination" *Experimental Brain Research* **145** 239–250
- Voisin J, Lamarre Y, Chapman C E, 2002b "Haptic discrimination of object shape in humans: contribution of cutaneous and proprioceptive inputs" *Experimental Brain Research* **145** 251–260
- Weber E, 1834/1996 *E. H. Weber on the Tactile Senses* 2nd edition (Hove, Sussex: Lawrence Erlbaum Associates, Taylor and Francis)
- Wheat H E, Goodwin A W, 2000 "Tactile discrimination of gaps by slowly adapting afferents: effects of population parameters and anisotropy in the fingerpad" *Journal of Neurophysiology* **84** 1430–1444
- Wichmann F A, Hill N J, 2001 "The psychometric function: II. Bootstrap-based confidence intervals and sampling" *Perception & Psychophysics* **63** 1314–1329

**Conditions of use.** This article may be downloaded from the E&P website for personal research by members of subscribing organisations. This PDF may not be placed on any website (or other online distribution system) without permission of the publisher.