

ON THE CONCENTRATION AND SEPARATION OF THE TRACE-ELEMENTS Fe, Cu, Zn, Mn, Pb, Mo and Co*

III. PAPER CHROMATOGRAPHY

P. C. VAN ERKELENS

Research Institute for Animal Husbandry "Schoonoord", Utrecht (The Netherlands)

(Received September 28th, 1960)

INTRODUCTION

In applying paper chromatography for the concentration and separation of trace elements, the following points must be kept in mind:

(1) When the sample has to be ashed, the use of sulfuric acid must be avoided (or the sulfate ions must be removed, *e.g.* by anion exchange), because sulfuric acid would either cause destruction or (after neutralization) overloading of the paper.

(2) Concentration of a large aqueous volume into a small spot on the paper is required for satisfactory separations.

(3) Overloading of the paper by macro-constituents has to be watched. The maximum permissible amounts depend on the thickness of the paper and on the nature of both the sample and the solvent. From 0.5 to 10 mg can be handled per cm of Whatman No. 1 paper for instance.

(4) Separations are generally good, but a solvent separating all the 7 elements involved in the present study is hard to find. Thus either a split sample solution or two successive solvents are required.

(5) Combination with spectrography, densitometry and activation analysis is simple but for flame photometry, titrimetry, polarography and spectrophotometry elutions are required.

Special adaptations to "on the spot" analysis have been made for titration (LACOURT¹), polarography (LANGER²), and several other electroanalytical methods including conductometry, oscillography, etc.³⁻⁸.

As was demonstrated earlier^{9,10}, only a few radio-active reagents can be applied in paper chromatography. Most reagents adhere firmly to the paper and thus produce a high blank.

Analysis by exchange with radio-active metal ions has as yet not been carried out on filter paper.

In our experiments complexing agents were avoided (in either the paper or the solvent), as these agents will in general interfere with subsequent quantitative determinations. In order to keep the method as simple as possible, electrochromatography and chromatography on alumina columns were not considered.

* Publication No. 128c of the Research Institute for Animal Husbandry "Schoonoord", Hoogt 10^{bis}, Utrecht (The Netherlands).

EXPERIMENTAL

The chemicals (see also part I and II) were all of reagent grade.

All papers contain traces of heavy metals (see part I). In Whatman No. 1 paper 0.1 to 1.0 μg per cm^2 are present. Iron occurs in small patches.

Washing of the paper with acidic methanol is the most effective method of purification⁹. Afterwards the paper must be neutralized and the water-content must be re-established.

Procedure: Cut strips of 2.5 or 3.0 \times 50 cm and hang them in a jar. Rinse in the descending way, with 9:1 methanol-hydrochloric acid for 1 day, dry for 2 h and rinse for 1 day with 9:1 methanol-ammonia. Finally dry, rinse for 1 day with 95:5 methanol-water and dry in the atmosphere of the last solvent. These papers contain⁹ about 0.03 μg of heavy metals per cm^2 .

The apparatus consisted of ordinary chromatographic jars and sprays, a densitometer (see part I) and a home-made scanner for radio-activity.

In ashing the sample the use of sulfuric acid has to be restricted. Mixtures of nitric acid and hydrogen peroxide were unsatisfactory, even with the use of catalysts; perchloric acid was considered to be too dangerous for routine work. Dry ashing was chosen. A muffle furnace, with the inner dimensions: 30 \times 17 \times 9 cm, was used (Heraeus MR 170). To avoid losses by evaporation*, the temperature was kept between 400 and 450°.

Procedure: Weigh 0.1 g of dry material in a fairly new silica crucible (volume about 15 ml), moisten with 1 ml of 1 N sulfuric acid, cover with a lid and char for 1 h in a sand-bath at about 200°. Heat for 3 h in the muffle at 400 to 450°, cool, moisten with nitric acid and again heat for 3 h. Finally cool and dissolve in 1 N hydrochloric or nitric acid. When the sample contains much silica, treat with hydrofluoric acid in a platinum crucible.

For the application of the sample to the paper, no satisfactory method was found for the routine handling of large volumes of acid solutions⁹. Thus evaporation to a small volume and dipping of the paper in the residue were chosen. Evaporation was carried

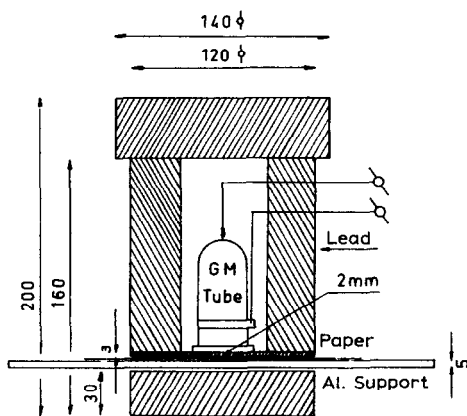

Fig. 1. Lead castle of scanner.

* These losses were checked with radio-isotopes.

out in the silica crucible, following the method of THIERS *et al.*¹¹; the final volume was 0.05 to 0.1 ml, the estimation of which is a matter of practice.

A washed paper strip was folded at 6 cm from one end and dipped into the residual solution until the spot was about 5 cm²; it was then dried in a clean atmosphere and dipped again until the crucible was empty (in all, 2 or 3 times). Experiments with radioisotopes indicated a 98% efficiency for this treatment.

Results were again checked with radio-isotopes* (see part I), but here the β -radiations were measured, with an end-window GM-tube (Fig. 1). ²¹⁰Pb was measured after some ²¹⁰Bi had grown in.

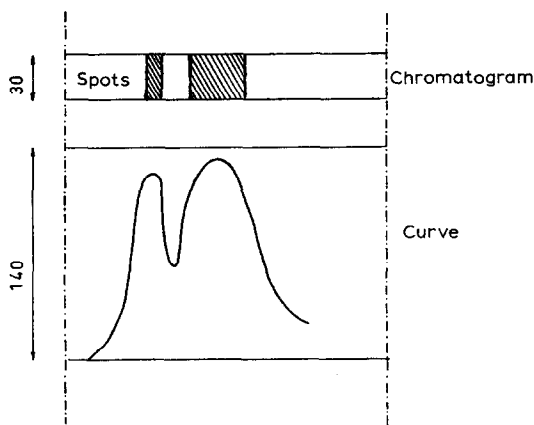

Fig. 2. Chromatogram and corresponding curve of the radioactive scan.

The peaks obtained with our scanning-apparatus and the GM-tube showed a distinct broadening as compared with the paper chromatogram (see Fig. 2). This broadening was probably due to secondary β 's from the accompanying γ -rays. Results with a scintillation counter were about the same, even when a 2 cm thick (2 mm wide) lead slit was applied. By comparison with simulated chromatograms, adequate conclusions could be drawn from the scanning curves.

RESULTS

All results were obtained at $25 \pm 1^\circ$. A solution of the ash of 0.1 g of dry cow liver in 0.1 ml of 1 N hydrochloric acid served as a sample. In general two techniques were employed:

(A) The spots were neither dried nor conditioned, and the chromatogram was run for 16 h, either in the ascending or in the descending way.

(B) The spots were dried for 1 h, conditioned for 16 h in the jar and run for 24 h in the ascending or in the descending way.

Fresh solvent mixtures were always used to develop the chromatograms, but the solvent(s) required for the atmosphere of the jar were added to it about 24 h before the experiment.

* Copper was checked by densitometric scans (see part I).

Preliminary experiments and a survey of the literature indicated that the solvents ketone-hydrochloric acid and higher alcohol-hydrochloric acid were the most promising.

Ketone-hydrochloric acid. These solvents have been used by many authors¹²⁻²⁹. From their results separations such as Mn — Co — Cu — Pb Fe Mo Zn — can be predicted.

In our experiments the atmosphere of the jar was made up from (1) acetone and (2) a saturated aqueous solution of ammonium nitrate.

The following solvents were applied (the composition is given in volume percentages):

- (1 and 2) acetone-12 N hydrochloric acid: 92-8 and 94-6.
- (3) acetone-8 N hydrochloric acid: 87-13.
- (4, 5 and 6) acetone-6 N hydrochloric acid: 90-10, 95-5 and 98-2.
- (7, 8 and 9) acetone-4 N hydrochloric acid: 80-30, 75-25 and 90-15.
- (10) acetone-1 N hydrochloric acid: 90-11.
- (11 and 12) acetone-butanol-12 N hydrochloric acid: 40-40-20 and 85-10-5.
- (13 to 18) acetone-butanol-6 N hydrochloric acid: 75-10-15, 80-10-10, 75-20-5, 88-10-2 and 78-20-2.
- (19) acetone-ethanol-isopropanol-6 N hydrochloric acid: 40-20-20-2.
- (20) acetone-ethylacetate-6 N hydrochloric acid: 45-45-10.
- (21) acetone-methylpropylketone-12 N hydrochloric acid: 50-42-8.
- (22) acetone-methylisopropylketone-6 N hydrochloric acid: 50-42-3.
- (23 and 24) methylisobutylketone-12 N hydrochloric acid: 92-8 and 90-6.
- (25 and 26) methylethylketone-12 N hydrochloric acid: 92-8 and 94-6.
- (27) methylethylketone-7 N hydrochloric acid: 75-25.

The most satisfactory separations were obtained with ascending chromatography as follows (the first figure designates the solvent and A or B indicates which technique was used) (see above):

9-A: Mn 40-Co 57-Pb 73-Cu 85-M 98,

13-B: Pb 5 to 20-Mn 35-Co 65-Cu 82-M 98, and

16-A: Mn 18-Co 38-Pb 59-Cu 66-M 98, in which the mean R_F -values of the elements are given and M stands for the mixture Fe + Zn + Mo.

Results with unwashed papers were slightly better than those with acid-washed ones. The most reproducible results were obtained with solvent 16. This solvent does not provide a very good separation of lead and copper. However, specific determinations on the paper are available for both elements; in addition a second separation of lead and copper can be obtained as described below.

Higher alcohol-hydrochloric acid. These solvents have also been applied by many authors^{12,13,14,22,28-40}. From their results^{11,13,14,20,26-39} separations such as Mn—Cu—Co—Pb—Fe—Mo—Zn can be predicted.

In our experiments the alcohol was either saturated or mixed with the hydrochloric acid. In the first case the atmosphere of the jar was made up from the two phases; in the second case the solvent alone was used for this purpose. Saturation of the alcohol with the acid was carried out at $25 \pm 1^\circ$, then 10% of alcohol was added, to prevent the separation of the solvent in two layers.

The following solvents were applied:

- (1 to 6) butanol saturated with 1, 2, 2.5, 3, 3.5 and 4 N hydrochloric acid respectively.
- (7) butanol-3.8 N hydrochloric acid: 15-4.
- (8 and 9) butanol-5 N hydrochloric acid: 10-5 and 9-1.
- (10 and 11) butanol-12 N hydrochloric acid: 80-20 and 95-5.

- (12) butanol saturated with water-12 *N* hydrochloric acid: 92-8.
 (13) butanol-12 *N* hydrochloric acid - conc. sulfuric acid: 60-12-1.
 (14) butanol-12 *N* hydrochloric acid - 3% hydrogen peroxide: 100-4-20.
 (15 and 16) butanol saturated with 1 *N* and 2 *N* hydrobromic acid.
 (17) butanol saturated with a 1:1 mixture of 2 *N* hydrochloric and 2 *N* nitric acid.
 (18 and 19) butanol-*n*-pentanol: 1-1, saturated with 2 *N* and 3 *N* hydrochloric acid.
 (20) butanol-isopropanol: 1-1, mixed with 5 *N* hydrochloric acid: 90-10.
 (21 and 22) *n*-pentanol saturated with 2 *N* and 3 *N* hydrochloric acid.
 (23) *n*-pentanol-12 *N* hydrochloric acid: 80-20.

The most satisfactory separation obtained was with solvent 3 or 4 and descending chromatography and with either of the techniques A or B: M' 8-Pb 22-Fe 41-Mo 67-Zn 88 in which again the mean R_F -values are given, and M' stands for the mixture Cu + Co + Mn. Results with washed and unwashed papers were similar. In contrast to WELLS¹⁵ no influence of the drying method (hot or cold) on the R_F -value of iron was observed.

As all the solvents selected proved to be unsatisfactory when used singly or in mixtures of 2 solvents, a split sample technique was adopted.

PROCEDURE

Dissolve the sample or its ash (see p. 227) in a minimum amount of hydrochloric or/and nitric acid; add radioactive tracers and evaporate to a small volume. Dip an acid-washed paper in the residue (see p. 228). Without further drying or conditioning,

TABLE I
COMPARISON OF PART I, II AND III

	<i>Ion exchange</i>	<i>Solvent extraction</i>	<i>Paper chromatography</i>
<i>System chosen</i>	<i>Cation exchange, with selective elution by acetone-HCl-H₂O mixtures</i>	<i>Acetylacetone, combined with diethyldithiocarbamate</i>	<i>Split sample, with the solvents: acetone-butanol-HCl and butanol-HCl</i>
Separation ^a obtained	Mo-Fe ^b -Co ^b Cu Mn Zn Pb	Mo-Fe-Mn-Zn-Pb-Co Cu	Mn-Co-Pb-Cu-Fe Mo Zn and Cu-Pb-Fe-Mo-Zn Co Mn
Ashing	Wet or dry	Wet or dry	Dry
Concentration of traces	Good	Good	Reasonable
Combination with quant. techniques	Excellent	Excellent: flame photometry, spectrography, activation analysis Partly: spectrophotometry, radiometric analysis Not: polarography	Excellent: spectrography, densitometry, activation analysis, some radioactive reagents Not: flame photometry, spectrophotometry, polarography, most radiometric techniques
Maximum sample (in g of dry cow liver)	3 (per 4 ml column)	1	0.1 per 2.5 cm width Whatman No. 1 paper 0.3 idem No. 3 MM

^a Required separations: Fe from Mn, Mo, Co; Cu from Co; Mn from Zn.

^b Further separation is possible by anion exchange from 9 *N* HCl.

^c Here activation can be carried out after the separation.

run the sample at 25° for about 16 h in the ascending way with the fresh solvent mentioned in the section on ketone-hydrochloric acid. The jar should be saturated with acetone and with a saturated solution of ammonium nitrate for 24 h before the experiment. Repeat this procedure with another part of the sample, using the solvent 3 or 4 mentioned in the section on higher alcohols-hydrochloric acid, this time chromatographing in the descending way. Dry both chromatograms and control the separation as described on p. 228.

CONCLUSIONS ON PART III. COMPARISON WITH PART I AND II

In conclusion, when a split sample is used, satisfactory results can be obtained with paper chromatography. As indicated in the introduction, the sample should be dry-ashed. Concentration of the trace elements is difficult. The size of the sample is restricted. Finally, combination with many quantitative techniques cannot easily be achieved. In general, paper chromatography does not offer many advantages over the separation techniques described in parts I and II. Its value depends of course on the problem to be handled. A comparison of the three techniques is given in Table I.

For general work, ion exchange is to be preferred, as combinations with quantitative techniques are easily made, while the size of the sample is in principle unlimited. When rapidity is of great value, solvent extraction is advantageous.

Paper chromatography can elegantly be combined with activation analysis carried out on the prepared chromatogram.

ACKNOWLEDGEMENT

The author's thanks are due to Miss J. H. F. F. BROEKMAN for valuable technical assistance.

SUMMARY

Paper chromatographic separations are described by which the minor constituents of biological ashes are separated either into: (Pb) - Mn - Co - (Pb) - Cu - Fe, Mo, Zn; or into: Cu, Mn, Co - Pb - Fe - Mo - Zn.

RÉSUMÉ

La chromatographie sur papier est utilisée pour la séparation des éléments oligodynamiques des cendres biologiques. Les séparations obtenues sont: (Pb) - Mn - Co - (Pb) - Cu - Fe, Mo, Zn, et Cu, Mn, Co - Pb - Fe - Mo - Zn.

ZUSAMMENFASSUNG

Papierchromatografische Trennungen der Bestandteilen von biologischen Aschen werden beschrieben. Die Spurenelemente dieser Aschen werden entweder getrennt in die Gruppen: (Pb) - Mn - Co - (Pb) - Cu - Fe, Mo, Zn; oder in die Gruppen: Cu, Mn, Co - Pb - Fe - Mo - Zn.

REFERENCES

1. A. LACOURT, *Ind. chim. belge*, 20 [4] (1955) 267. 399.
2. A. LANGER, *Anal. Chem.*, 28 (1956) 426.
3. L. PINTERIC AND M. D. POULIK, *Can. J. Public Health*, 45 (1954) 163; *Nature*, 176 (1955) 1226.
4. T. YAMADA, *Japan Analyst*, 3 (1954) 215.
5. J. A. BROOMHEAD AND N. A. GIBSON, *Chem. & Ind. (London)*, (1956) 1474.
6. K. BOLENSKY, W. LOGINOW AND P. TOWARZ, *C.A.*, 52 (1958) 15322 c and 18065 i.
7. M. HEJTMÁNEK AND J. HEJTMÁNKOVÁ, *Chem. listy*, 52 (1958) 444.
8. G. G. BLAKE, *Anal. Chim. Acta*, 21 (1959) 545.
9. P. C. VAN ERKELENS, *Thesis*, Utrecht, 1960.

- ¹⁰ P. C. VAN ERKELENS, to be published in this journal (1961).
- ¹¹ R. E. THIERS, J. F. WILLIAMS AND J. H. YOE, *Anal. Chem.*, 27 (1955) 1725.
- ¹² T. V. ARDEN, F. H. BURSTALL, G. R. DAVIES, J. A. LEWIS AND R. P. LINSTED, *Nature*, 162 (1948) 691.
- ¹³ F. H. BURSTALL, G. R. DAVIES, R. P. LINSTED AND R. A. WELLS, *Nature*, 163 (1949) 64; F. H. BURSTALL, G. R. DAVIES AND R. A. WELLS, *Discussions Faraday Soc.*, 7 (1949) 179; F. H. BURSTALL, G. R. DAVIES, R. P. LINSTED AND R. A. WELLS, *J. Chem. Soc.*, (1950) 516.
- ¹⁴ J. A. LEWIS AND J. M. GRIFFITHS, *Analyst*, 76 (1951) 388.
- ¹⁵ R. A. WELLS, personal communication (1953).
- ¹⁶ E. C. HUNT, A. A. NORTH AND R. A. WELLS, *Analyst*, 80 (1955) 172.
- ¹⁷ A. LACOURT, *Mededel. Vlaam. Chem. Ver.*, 12 (1950) 76.
- ¹⁸ A. LACOURT, J. GILLARD AND M. V. D. WALE, *Mikrochemie ver. Mikrochim. Acta*, 35 (1950) 262.
- ¹⁹ A. LACOURT, G. H. SOMMEREYNS, ED. GEINDT AND OD. JACQUET, *Mikrochemie ver. Mikrochim. Acta*, 36 (1951) 117.
- ²⁰ A. LACOURT, G. H. SOMMEREYNS AND J. SOETE, *Mikrochemie ver. Mikrochim. Acta*, 38 (1951) 348.
- ²¹ R. L. DAVIES, *Nature*, 168 (1951) 834.
- ²² M. SHIBATA AND T. VEMURA, *J. Chem. Soc. Japan, Pure Chem. Sect.*, 72 (1951) 541.
- ²³ J. N. BALSTON AND B. E. TALBOT, *A guide to filter paper- and cellulose-powder-chromatography*, Reeve-Angel, London, 1952.
- ²⁴ A. K. MAJUMDAR AND M. M. CHAKRABARTY, *Anal. Chim. Acta*, 17 (1957) 415.
- ²⁵ G. BÖNIG, *Landwirtsch. Forsch.*, 6 (1954) 37; 9 (1956) 97.
- ²⁶ M. LEDERER, *Anal. Chim. Acta*, 8 (1953) 134.
- ²⁷ E. M. BARILARI AND M. DE UÑA DE CARLETTO, *Rev. asoc. bioquím. arg.*, 20 (1955) 173.
- ²⁸ G. D. ELISEEVA, *Izvest. Vysshyykh ucheb. zavedenii khim. i khim. tekhnol.*, (1958) 35.
- ²⁹ W. J. FRIERSON, D. A. REARICK AND J. H. YOE, *Anal. Chem.*, 30 (1958) 468.
- ³⁰ M. LEDERER, *Nature*, 162 (1948) 776; 163 (1949) 598; *Anal. Chim. Acta*, 3 (1949) 476; 4 (1950) 629; 5 (1951) 185; *J. Australian Chem. Inst.*, (1950) 308.
- ³¹ J. R. A. ANDERSON AND M. LEDERER, *Anal. Chim. Acta*, 4 (1950) 513.
- ³² W. R. WALKER AND M. LEDERER, *Anal. Chim. Acta*, 5 (1951) 191.
- ³³ G. BOUSSIÈRES AND M. LEDERER, *Bull. soc. chim. France*, (1952) 904.
- ³⁴ G. H. OSBORN AND A. JEWSEBURY, *Nature*, 164 (1949) 443.
- ³⁵ W. J. FRIERSON AND M. J. AMMONS, *J. Chem. Educ.*, 27 (1950) 37.
- ³⁶ W. J. FRIERSON AND J. W. JONES, *Anal. Chem.*, 23 (1951) 1447.
- ³⁷ B. SARMA, *Sci. and Culture (Calcutta)*, 16 (1950) 165.
- ³⁸ J. R. BISHOP AND H. LIEBMANN, *Nature*, 167 (1951) 524.
- ³⁹ S. HARASAWA, *J. Chem. Soc. Japan, Pure Chem. Sect.*, 72 (1951) 107, 110, 236, 423.
- ⁴⁰ F. H. POLLARD AND J. F. W. MCOMIE, *J. Chem. Soc.*, (1953) 1338.