

Effects of variation in posture and respiration on RSA and pre-ejection period

JAN H. HOUTVEEN,^a PAUL F.C. GROOT,^b AND ECO J.C. DE GEUS^b

^aDepartment of Health Psychology, Utrecht University, Utrecht, The Netherlands

^bDepartment of Biological Psychology, Vrije Universiteit, Amsterdam, The Netherlands

Abstract

The extent to which variation in posture and respiration can confound pre-ejection period and respiratory sinus arrhythmia (RSA) as indices of cardiac sympatho-vagal activity was examined. Within-subjects changes in these measures were assessed in 36 subjects during different postures and (paced) respiratory frequencies. Changes from supine to sitting to standing led to reduced RSA values and longer pre-ejection periods, reflecting the known decrease in vagal but not the increase of sympathetic activity. Multilevel path analysis showed that within-subjects changes in sympatho-vagal balance were faithfully reflected by changes in interbeat interval, but imperfectly by changes in RSA and pre-ejection period. It was concluded that pre-ejection period should be stratified for posture and RSA for respiratory frequency to reliably index changes in sympatho-vagal balance when these factors are prone to change (e.g., during 24-h ambulatory recording)

Descriptors: Sympatho-vagal balance, Posture, Respiration, Interbeat interval, Pre-ejection period, RSA, CO₂

In psychophysiology, respiratory sinus arrhythmia (RSA) and pre-ejection period are frequently used as noninvasive measures of within-subjects changes in vagal and sympathetic (beta-adrenergic) influences on the heart. The validity of these measures derives from a large body of controlled experimental studies using exposure to exercise, infusion of beta-adrenergic agonists, mental stressors, and blockade of cardiac muscarinic and adrenergic receptors to manipulate cardiac sympathetic and vagal activity (Allen & Crowell, 1989; Cacioppo, Berntson, et al., 1994; Grossman & Kollai, 1993; Krzeminski et al., 2000; Mezzacappa, Kelsey, & Katkin, 1999; Newlin & Levenson, 1979; Penttila et al., 2001; Sherwood, Allen, Obrist, & Langer, 1986; Sherwood, McFetridge, & Hutcheson, 1998; Smith et al., 1989; Svedenahg, Martinsson, Ekblom, & Hjendahl, 1986). However, two mechanisms have been identified that may affect the validity of these noninvasive indices of cardiac sympatho-vagal balance outside the controlled laboratory environment. Changes in respiratory frequency influence RSA independent of tonic vagal modulation (Berntson, Cacioppo, & Quigley, 1993; Berntson et al., 1997; Grossman & Kollai, 1993; Houtveen, Rietveld, & de Geus, 2002) whereas posture-related changes in preload (ventricular filling) and afterload (aortic diastolic pressure) may influence

pre-ejection period independent of cardiac inotropic drive (Lewis, Rittogers, Forester, & Boudoulas, 1977; Sherwood et al., 1990).

In a typical psychophysiological study, the subject's posture is fixed, usually sitting upright, whereas changes in respiratory frequency in response to the mental (usually emotional) stimuli are relatively mild, for example, increases of 20% over the spontaneous resting frequency. This is different in ambulatory settings, however, particularly those that include both nighttime and daytime recordings. In such settings repeated postural changes are the rule rather than the exception, and respiratory frequency may be much more variable, for instance, due to physical activity and sleep. This problem has arisen with the advent of high quality instruments to reliably measure pre-ejection period and RSA in ambulatory settings (Cybulski, 2000; de Geus & van Doornen, 1996; Grossman, Wilhelm, & Spoerle, 2004; Keenan, 2004; Sherwood et al., 1998; Willemsen, de Geus, Klaver, van Doornen, & Carroll, 1996). Ambulatory designs that capitalize on these new instruments are prone to confound theoretically relevant psychological effects of real-life activities with changes in posture and respiratory frequency. Typical examples are studies that contrast ambulatory recordings from daytime sitting/standing at (stressful) episodes of work to a resting baseline obtained during nighttime sleep recordings (Riese, van Doornen, Houtman, & de Geus, 2004; Vrijkkotte, van Doornen, & de Geus, 2004). To properly interpret the outcome of such studies, it is important to obtain a better understanding of the independent effects of changes in posture and respiratory frequency, and their interaction, on changes in pre-ejection period and RSA.

Although the effect of respiration on RSA has been extensively studied before, parallel respiration effects on pre-ejection period are unknown. Postural effects on pre-ejection period and

This study was funded by a grant from the Netherlands Organization for Scientific Research (NWO No. 452-02-011). The authors gratefully acknowledge the aid of Marte Kaan and Ferdinand Schulte for their assistance in data collection and Marjolijn Raaijmakers for her assistance in analyzing the data.

Address reprint requests to: Jan Houtveen, Department of Health Psychology, Utrecht University, P.O. Box 80140, 3508 TC Utrecht, The Netherlands. E-mail: j.h.houtveen@fss.uu.nl.

RSA have been examined simultaneously in only one study (Caiozzo, Berntson, et al., 1994) but, unfortunately, this careful study did not include a supine position, which is the most relevant posture from the perspective of an ambulatory study that includes sleep recordings. In the current study, we capitalized on an experimental protocol originally designed to validate impedance cardiography as a means to measure tidal volume (Houtveen, Groot, & de Geus, 2005). This design combined postural changes from supine to sitting to standing with paced breathing at three different frequencies. This allowed us to examine the main and interactive effects of changes in posture (including a supine position) and changes in respiratory frequency (and the related changes in respiratory depth and the arterial partial pressure of CO₂) on RSA, pre-ejection period, and heart period.

Methods

Participants

The participants of the study were 38 healthy subjects aged 18–50. Due to technical problems, only partial data were available for 2 participants, resulting in 36 complete data sets, 18 men (age $M = 30.1$ years, $SD = 10.5$) and 18 women (age $M = 29.8$ years, $SD = 8.8$). The study was presented as an investigation of breathing patterns. The participants received 10 euros after the experiment. All participants gave written informed consent.

Posture and Paced Breathing Conditions

The experiment consisted of 12 different breathing conditions, each of them of 2 min duration. In three different postures (supine, sitting, and standing), the order of which was randomized, subjects breathed at four paced frequencies, the order of which was fixed: (a) spontaneous breathing without pacing, (b) paced breathing at a rate of 25 cpm without pause, (c) paced breathing at a rate of 15 cpm combined with 0.4 s. pause, and (d) paced breathing at a rate of 5 cpm combined with 1 s pause. A visual pacing signal was presented on a 15-in. monitor, positioned at 80 cm in front of them, and consisted of a respiratory-like sinusoid signal with adjustable amplitudes (highest during slow breathing, lowest during fast breathing).

Physiological Recordings

General. Because capnometry was performed after 30 and 90 s of each 2-min breathing condition, the intermediate segment (60 s) was retained as artifact-free heart period and respiratory data period. The mean interbeat interval, RSA, pre-ejection period, and respiratory frequency and amplitude (depth) values were pooled over these 60-s segments for each breathing condition. End-tidal CO₂ (PetCO₂) values were pooled over the two observations for each condition.

Interbeat interval, RSA, and pre-ejection period. The electrocardiogram (ECG) and the impedance cardiogram (ICG) were recorded continuously with the Vrije Universiteit Ambulatory Monitoring System (VU-AMS version 4.3; de Geus, Willemsen, Klaver, & van Doornen, 1995; Willemsen et al., 1996). This system uses six disposable, pregelled Ag/AgCl electrodes. The first ECG/ICG electrode was placed on the sternum over the first rib between the two collarbones. The second ECG electrode was placed at the apex of the heart over the ninth rib on the left lateral margin of the chest approximately 3 cm under the left nipple. The second ICG measuring electrode was placed over the tip of the

xiphoid complex of the sternum. The ICG current electrodes were placed on the back over cervical vertebra C4 and between thorax vertebrae T8 and T9. A ground electrode was placed at the lower right abdomen. Electrode resistance was kept low by cleaning the skin with alcohol and rubbing.

The interbeat intervals were obtained from the ECG by an on-line automated R-wave peak detector. RSA was estimated by two methods. First, uniformly spaced samples were created and discrete Fourier transformed to compute the high frequency heart period variability spectral power values (high frequency power: 0.125–0.5 Hz). This method does not capture respiratory sinus arrhythmia below the lowest frequency in this band (i.e., 0.125 Hz), whereas our 5 cpm pacing condition causes fluctuations in heart rate at a frequency below this range (0.0833 Hz). Therefore, RSA was also estimated by the peak-to-valley method (RSA_{pv}) as the mean difference between the shortest heart period associated with inspiration and the longest heart period associated with expiration for each respiratory cycle (Berntson et al., 1997; Grossman, van Beek, & Wientjes, 1990).

The impedance signal measured by the ICG was amplified and led to a precision rectifier. The rectified signal was filtered at 72 Hz (low pass) to give thorax impedance Z_0 . Filtering Z_0 at 0.1 Hz (high pass) supplies dZ , which in turn was filtered at 30.0 Hz (high pass) to obtain dZ/dt , the high frequent impedance changes due to the ejection of blood into the aorta during systole. The resulting dZ/dt were transmitted to the A/D converter of the microprocessor and sampled at 250 Hz. The usual approach to dZ/dt data reduction—ensemble averaging—was implemented in the VU-AMS device at the hardware level. Ensemble averaging involves digitizing the dZ/dt only during a short period (512 ms) around each R-wave in a block of 30 s duration. These digitized samples were summed and divided by the number of synchronized beats in the block. This procedure reduced the impact of single beat fluctuations in the impedance signal through respiration and slow thorax movement. The pre-ejection period (in milliseconds) was defined as the interval from the R-wave peak, minus a fixed interval of 48 ms (Willemsen et al., 1996; Sherwood et al., 1990) to the upstroke of the dZ/dt (“B-point”), which signals opening of the aortic valves.

Respiration. Changes in thoracic and abdominal circumference (used to assess respiratory frequency, respiratory depth, and RSA_{pv}) were measured with two BioPac TSD201 respiratory effort transducers (see <http://www.biopac.com>). The two respiratory belts were attached over (a) the rib cage at the level of the fifth thoracic vertebrae, and (b) the abdomen at the level of the navel. The transducers have a variable resistance output between 50 and 125 K Ω . These signals were low-pass filtered (1 Hz), sampled at 25 Hz, and registered by a BIOPAC MP150 system connected to a data-acquisition computer running the acknowledge v3.7.3 software package. Both respiration signals (thoracic and abdominal) were band-pass filtered using a FIR filter 0.05–0.5 Hz (3–30 cpm). Next, interactive scoring of the peaks and troughs in these segments yielded the respiratory frequency, amplitude, and RSA_{pv} values on a breath-to-breath basis.

Capnometry. The TG-951T CO₂ sensor Kit (Nihon Kohden Corp.) was used to measure the partial pressure of CO₂ at the end of a normal expiration (PetCO₂). Digitized PetCO₂ values (in millimeters of mercury) from the capnometer sensor kit were sent to the data-acquisition computer through an RS-232 interface cable.

Procedure

All experimental sessions took place between 10 a.m. and 4 p.m. and lasted approximately 45 min. First, the six ECG/ICG recording electrodes and the two respiratory belts were attached. Subjects then received a general explanation of the experimental protocol and were seated in a sound-shielded and dimly lit cabin. A practice session took place to familiarize the participants with the pacing. Next, the three 8-min (i.e., four times 2 min: normal breathing, 25 cpm, 15 cpm, and 5 cpm) breathing sessions took place in supine, sitting, and standing postures. During each 2-min breathing condition subjects exhaled through the capnometer mouthpiece after 30 and 90 s. Each breathing session was followed by a short break. Throughout, signal quality of the ECG/ICG and respiratory belts were checked, and, if necessary, the electrodes/belts were reattached during these breaks. At the end of the three breathing sessions, all equipment was disconnected and participants were debriefed and paid.

Statistical Data Analysis

High frequency power, RSA_pv, and respiratory amplitude values were $\log^{10}(x + 1)$ transformed to obtain normal distributions. Repeated-measures Posture (3) \times Pacing (4) ANOVA tests (implemented as MANOVA using SPSS 12) were performed for the observed interbeat interval, pre-ejection period, high frequency power, RSA_pv, PetCO₂, respiratory frequency, and respiratory amplitude values.

Next, change scores were computed for each measure and subject across the nine paced breathing conditions by subtracting the value of the sitting, 15-cpm breathing condition. These change scores were Z-transformed across subjects and conditions. A multilevel path-analysis (using Mplus V3.0) was performed on the Z-transformed change scores to test the interrelationships between these measures (using RSA_pv), separately at the between-subjects level and at the within-subjects level. Because within-subjects polynomial contrast tests unambiguously indicated linear effects of the posture conditions on the physiological measures, the posture variable was included in this model as -1, 0, 1 for, respectively, supine, sitting, and standing.

Results

Repeated-Measures Analysis of Variance Tests

Table 1 shows the mean scores for all the experimental conditions. In analyses of interbeat interval, a main effect of posture was found, $F(2,34) = 66.18$, $p < .001$. Within-subjects contrast tests indicated significant differences between all three posture conditions, all $p < .001$. Changes from supine to sitting to standing postures led to a linear shortening of interbeat interval, $p < .001$. Changes in pacing were also reflected in interbeat interval, $F(3,33) = 19.40$, $p < .001$, but this effect interacted with posture (Posture \times Pacing: $F[6,30] = 12.80$, $p < .001$). Post hoc decomposition of this interaction showed that the interbeat interval was increased in the 5 cpm condition during sitting and standing, but not during the supine position, $p < .01$.

In analyses of pre-ejection period, a main effect of posture was found, $F(2,34) = 40.89$, $p < .001$. Within-subjects contrast tests indicated significant differences between all three posture conditions, all $p < .001$. Changes from supine to sitting to standing postures led to a linear effect in the lengthening of pre-ejection period, $p < .001$. No main effect of pacing and no interaction effect of Posture \times Pacing were found for pre-ejection period.

Main effects of posture were found for high frequency power and for RSA_pv, $F(2,34) = 25.66$, $p < .001$; $F(2,34) = 37.78$, $p < .001$. For both measures, within-subjects contrast tests indicated significant differences between all three posture conditions, all $p < .01$. Changes from supine to sitting to standing postures led to a linear decrease of high frequency power and RSA_pv, $p < .01$. Main effects of pacing were also found for high frequency power, $F(3,33) = 38.11$, $p < .001$, and for RSA_pv, $F(3,33) = 397.41$, $p < .001$. For both measures, within-subjects contrast tests indicated significant differences between all pacing conditions, all $p < .001$. A decrease in pacing frequency led to a linear increase of RSA, $p < .001$. Interaction effects of Posture \times Pacing were also found for high frequency power, $F(6,30) = 6.00$, $p < .001$, and for RSA_pv, $F(6,30) = 8.77$, $p < .001$. For high frequency power, a ceiling effect was found at 5-cpm breathing in the supine position. In the 15- and 25-cpm breathing conditions a significant difference, $p < .001$, was found between sitting and supine postures,

Table 1. Means (SD) of the Physiological Values

	IBI	PEP	HF power	RSA _p v	PetCO ₂	R amplitude	R frequency
Supine							
No pacing	0.999 (0.18)	94.9 (15)	3.14 (0.67)	1.87 (0.30)	34.16 (4.6)	0.454 (0.22)	14.47 (4.3)
25 cpm	0.966 (0.16)	93.8 (16)	2.89 (0.62)	1.61 (0.29)	32.11 (3.9)	0.380 (0.20)	24.57 (0.28)
15 cpm	0.954 (0.15)	93.9 (16)	3.04 (0.61)	1.81 (0.29)	33.31 (5.3)	0.467 (0.24)	15.09 (0.53)
5 cpm	0.948 (0.14)	94.3 (15)	3.09 (0.52)	2.27 (0.27)	36.69 (5.4)	0.648 (0.26)	5.23 (0.31)
Sitting							
No pacing	0.902 (0.13)	102.9 (21)	2.89 (0.64)	1.79 (0.33)	34.39 (4.0)	0.409 (0.21)	14.73 (3.5)
25 cpm	0.880 (0.12)	103.2 (19)	2.64 (0.58)	1.56 (0.25)	30.52 (4.5)	0.346 (0.16)	24.60 (0.25)
15 cpm	0.865 (0.12)	103.2 (19)	2.84 (0.54)	1.72 (0.29)	31.05 (5.3)	0.419 (0.18)	15.01 (0.18)
5 cpm	0.886 (0.12)	103.1 (19)	3.09 (0.49)	2.37 (0.29)	34.72 (6.4)	0.630 (0.22)	5.15 (0.40)
Standing							
No pacing	0.798 (0.12)	107.9 (21)	2.56 (0.52)	1.63 (0.29)	33.23 (4.8)	0.476 (0.23)	14.42 (3.5)
25 cpm	0.769 (0.11)	108.9 (21)	2.32 (0.51)	1.32 (0.19)	29.66 (4.6)	0.401 (0.18)	24.56 (0.22)
15 cpm	0.750 (0.11)	109.9 (20)	2.55 (0.47)	1.53 (0.25)	29.57 (4.8)	0.469 (0.22)	15.14 (0.36)
5 cpm	0.802 (0.10)	109.5 (20)	3.00 (0.41)	2.26 (0.24)	33.56 (5.5)	0.727 (0.29)	5.49 (0.76)

IBI: interbeat interval (s); PEP: pre-ejection period (ms); HF power: high frequency heart period variability power; RSA_pv: RSA estimated by the peak-to-valley method. HF power and RSA_pv are in $\log^{10}(x+1)$ transformed units of ms² and ms; PetCO₂ values are in units of mmHg; respiratory amplitude values are in $\log^{10}(x+1)$ transformed (arbitrary) voltage units; respiratory frequency values are in units of cpm.

but this difference was no longer significant at 5-cpm breathing. For RSA_pv no ceiling effect was found at 5 cpm, but the difference between RSA_pv in the 15- and 5-cpm paced breathing conditions was significantly reduced in the supine position as compared to the standing and sitting positions, $p < .05$.

Changes in pacing were also reflected in PetCO₂, $F(3,33) = 38.09$, $p < .001$. The PetCO₂ values were decreased for the 25- and 15-cpm pacing frequencies as compared to no pacing condition, $p < .001$. No interaction effect of Posture \times Pacing was found for PetCO₂. An unexpected main effect of posture was, however, found for PetCO₂, $F(2,34) = 14.86$, $p < .001$. Within-subjects contrast tests indicated significant differences between all three posture conditions, all $p < .01$. Changes from supine to sitting to standing postures led to a linear reduction of PetCO₂, $p < .01$.

The expected main effects of pacing were found on respiratory amplitude, $F(3,33) = 67.03$, $p < .001$, and respiratory frequency, $F(3,33) = 25760.36$, $p < .001$. For both measures, within-subjects contrast tests indicated significant differences between all three pacing frequencies, all $p < .001$. The no pacing condition, however, did not significantly differ from the 15-cpm condition. This simply reflects the closeness of this pacing frequency to the average spontaneous breathing frequency of this group ($M = 14.87$, $SEM = 0.15$ cpm). No main effect of posture and no interaction effect of Posture \times Pacing were found for either respiratory amplitude or frequency.

Exploratory Multilevel Path Analysis

More insight into the relationships between these physiological measures can be obtained from the results of the exploratory multilevel (between- and within-subjects) path analysis. The final

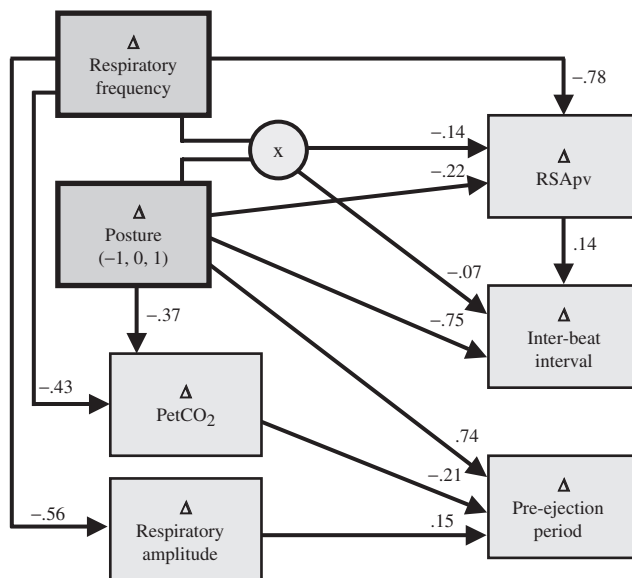

Figure 1. Standardized within-subjects path diagram. Only significant path coefficients (estimate/ SE estimate > 1.96) are shown. The dark gray boxes signal the experimental manipulations; the direction of causation is fixed for arrows flowing from these boxes. Other arrows reflect correlations and causality could, in principle, have been bidirectional. The linear change in interbeat interval, respiratory amplitude, and PetCO₂ with our manipulations, however, suggests that the direction of the arrows is as in our model. The interaction of Posture \times Respiratory frequency is created by multiplication of both variables and added to the model as an additional variable ("x" in circle).

selected model resulted in an acceptable goodness of fit, $\chi^2(12) = 12.27$, $p = .42$. In this model, no significant variance was accounted for at the between-subjects level. The within-subjects model explained 60% of the variance in interbeat interval change, 67% of the variance in RSA_pv change, 51% of the variance in pre-ejection period change, 35% of the variance in respiratory amplitude change, and 31% of the variance in PetCO₂ change. Figure 1 shows the corresponding significant standardized beta values.

Although most beta values replicate the effects of posture and pacing found in the repeated-measures analysis of variance tests (see above), four remarkable additional results were found. First, no significant path (beta = $-.12$) was found from changes in pre-ejection period to changes in interbeat interval and an unexpected low beta value (.14) was found in the link between changes in RSA_pv and interbeat interval. This illustrates how, under the conditions of the current study, changes in pre-ejection period and RSA fail to reflect changed cardiac sympathetic and parasympathetic activity. Second, PetCO₂ was not only influenced by changes in respiratory frequency but also by postural change. Third, pacing-induced changes in respiratory amplitude (beta = $-.03$) and PetCO₂ (beta = $.04$) did not have significant paths to RSA_pv. Finally, although the pacing manipulation did not influence pre-ejection period overall, pacing-induced changes in respiratory amplitude and PetCO₂ did have significant effects on pre-ejection period: An increase in PetCO₂ decreased pre-ejection period and an increase in respiratory amplitude increased pre-ejection period.

Discussion

The purpose of the current study was to estimate the influence of systematically manipulated changes in posture and respiratory frequency on within-subjects changes in two frequently used noninvasive measures of cardiac sympathetic and vagal activity, the pre-ejection period and RSA, respectively. Changes from supine to sitting to standing postures led to a shortening of interbeat interval and a decrease in RSA, reflecting the expected decrease in cardiac vagal activity that has been well documented in studies using either passive head-up tilting or active standing (Cooke et al., 1999; Furlan et al., 2000; Matsushima, Tanaka, & Tamai, 2004; Mukai & Hayano, 1995; Siebert, Drabik, Lango, & Szyndler, 2004).

The same postural manipulation led to a stepwise increase in pre-ejection period, which would suggest a decrease in beta-adrenergic influence on the heart from supine to standing. This is, however, incompatible with the known effects of these changes in posture. Head-up tilting is well known to be accompanied by an increase in muscle sympathetic nerve activity (Cooke et al., 1999; Furlan et al., 2000; Saito et al., 1997; Shoemaker, Hogeman, Khan, Kimmerly, & Sinoway, 2001), noradrenergic spillover (Erms et al., 2004; Esler et al., 1988; Furlan et al., 2000; Laszlo, Rossler, & Hinghofer-Szalkay, 2001), and cardiac contractility (Vijayalakshmi, Mohan, & Babu, 2002). Physiologically, this increase in sympathetic activity makes good sense. Assumption of the upright posture leads to a gravity-induced displacement of blood to the lower body and a small reduction in total plasma volume (Chae & Suh, 1993; Frey, Tomaselli, & Hoffer, 1994; Laszlo et al., 2001; Toska & Walloe, 2002). This reduces end-diastolic left ventricular filling, which, according to the Frank-Starling principle, in turn, reduces the contractility of the left

myocard. Indeed, end-diastolic and stroke volume are found to be reduced in the upright position (Boudoulas, Barrington, Olson, Bashore, & Wooley, 1985; Chae & Suh, 1993; Frey et al., 1994; Shannon, Maher, Santinga, Royal, & Wei, 1991; Sherwood & Turner, 1993; Shoemaker et al., 2001; Toska & Walloe, 2002; Waldstein, Neumann, & Merrill, 1998). The decrease in stroke volume is compensated by an increase in heart rate that is secondary to vagal withdrawal and increased cardiac sympathetic activity. Normally, therefore, we should expect the pre-ejection period to shorten in passive tilting, and this decrease should even be enhanced in active standing when afferent muscle feedback serves to further increase sympathetic activity.

The paradoxical increase in pre-ejection period when going from sitting to standing has been demonstrated before (Boudoulas et al., 1985; Cacioppo, Uchino, & Berntson, 1994; Cacioppo, Berntson, et al., 1994; Sherwood & Turner, 1993; Waldstein et al., 1998), and head-up tilting from supine to upright is also known to systematically increase pre-ejection period (Frey & Kenney, 1979; Lewis et al., 1977; Ovadia, Gear, Thoele, & Marcus, 1995). Importantly, the increase in pre-ejection period during head-up tilting is not abolished by beta blockade (Ovadia et al., 1995). The failure of the pre-ejection period to correctly index changes in sympathetic activity across postural change is likely due to the large afterload effects induced by postural changes. Afterload, or end-diastolic aortic pressure, is reflected in mean arterial pressure, which is known to increase when going from supine to upright (Chae & Suh, 1993; Cooke et al., 1999; Frey et al., 1994; Laszlo et al., 2001; Shannon et al., 1991; Sherwood & Turner, 1993; Shoemaker et al., 2001; Toska & Walloe, 2002; Waldstein et al., 1998). Higher afterload will elongate pre-ejection period by prolonging the time needed to open the aortic valve, even if contractility is unchanged. The low (or even reversed) pre-ejection period reactivity found during cold stress is another instance of the impact of afterload on pre-ejection period, where changes in pre-ejection period fail to detect the strong increase in sympathetic nerve activity (van Doornen, Snieder, & Boomsma, 1998; van Eekelen, Houtveen, & Kerkhof, 2004; Frey & Kenney, 1979; Montoya, Brody, Beck, Veit, & Rau, 1997). In contrast to the strong posture effect, changing the respiratory frequency had virtually no effect on the pre-ejection period. However, pacing-induced decreases in respiratory depth and increases in PetCO₂ both mildly decreased pre-ejection period.

A relationship between within-subjects changes in RSA and changes in respiratory frequency has repeatedly been described and/or demonstrated before (Berntson et al., 1997; Eckberg, 2003; Grossman et al., 2004; Houtveen et al., 2002; Sasano et al., 2002). Our results suggest that the modulation of respiration on the association between RSA and cardiac vagal activity may be posture specific. However, sympathetic influences could have contaminated our RSA_{pv} measure, specifically in the 5-cpm breathing conditions and, therefore, could also have been responsible for this interaction effect. At 5 cpm, the typical low frequency sympathetic versus high frequency vagal filter characteristics do not differentiate vagal and sympathetic contributions anymore (see Berntson et al., 1993). Thus, reduced sympathetic activation in the supine position could very well have been responsible for the relatively reduced RSA_{pv} values found in the 5-cpm supine condition as compared to the 15-cpm supine condition. Pacing-induced effects of respiratory depth and the arterial partial pressure of CO₂ on RSA have not been demonstrated in the current study. However, our design did not allow us to discriminate between the primary effects of res-

piratory rate, depth, and CO₂ on RSA. These effects may emerge in a (full factorial) experimental design with independent and larger respiratory depth and CO₂ variation.

Under normal—posture controlled—experimental conditions, within-subjects changes in RSA and pre-ejection period can be used as indices of the vagal and sympathetic beta-adrenergic control of the heart period (e.g., see Cacioppo, Berntson, et al., 1994; de Geus & van Doornen, 1996). The results of the current study, however, demonstrate that changes in posture and respiratory frequency (and the related changes in depth and PetCO₂) exert large effects on these noninvasive sympatho-vagal measures, such that within-subjects changes in heart period can become almost unrelated to changes in RSA and pre-ejection period. The question arises, therefore, whether pre-ejection period and RSA can be used to index changes in cardiac sympathetic and parasympathetic activity under circumstances when no experimental control over posture or respiration is possible, for example, during ambulatory monitoring. We are optimistic that this is still feasible as long as the study design fully appreciates the inherent limitations of these measures demonstrated here. The modulation of the relationship between vagal activity and RSA by respiratory frequency can be explicitly charted in field studies by recording both RSA and respiratory frequency as has been proposed before (Grossman et al., 2004). As long as postural changes are carefully documented, for instance, by inbuilt movement and posture detectors, it is further possible to compare different activities/moods across instances of these activities performed in the same posture.

At first sight, this seems to limit the research questions that can be addressed. Some of the more interesting within-subjects comparisons come with an inherent change in posture, for instance, when daytime work levels of pre-ejection period/RSA are compared to the sleeping baseline value of these measures. Careful interpretation of the results, however, may overcome the potential shortcomings of pre-ejection period and RSA in such naturalistic designs. As an example we point to a recent ambulatory monitoring study that reported *increased* pre-ejection period values during sleep (+6.4 ms) as compared to daytime sitting (Vrijkotte et al., 2004). In the present study, we demonstrated that the change from sitting to supine posture by itself leads to a *decrease* in pre-ejection period (−8 ms). Apparently, the decrease in activity of the beta-adrenergic influence on the heart during sleep is strong enough to overcome the opposing afterload effects on pre-ejection period. The conclusions of Vrijkotte et al. (2004) that there is a significant recovery of cardiac sympathetic activity at night, therefore, seems entirely valid, and is supported by studies showing an increase in pre-ejection period from a presleep supine baseline (Burgess, Penev, Schneider, & van Cauter, 2004; Trinder et al., 2001). However, their finding that subjects with the highest work stress showed the least awake/sleep differences in pre-ejection period should be interpreted with more care. As the authors suggested, this effect may reflect a true work stress effect on wake–sleep changes in cardiac sympathetic effects on the heart, driven by beta-receptor down-regulation. Alternatively, however, it may reflect a work stress effect on posture or sleep-induced changes in afterload (blood pressure “dipping”) that may be entirely unrelated to cardiac sympathetic regulation.

In general, the results of the current study confirm the necessity of stratifying for posture and respiration when using pre-ejection period and RSA to index within-subjects changes in sympatho-vagal balance. Valid interpretation of changes in

pre-ejection period and RSA is entirely feasible in studies that, by necessity, confound measurement conditions with changes in posture and respiration, for instance, when ambulatory recordings from daytime sitting/standing at work are compared with nighttime supine sleep. These studies do, however, require a de-

sign that takes the significant postural and respiration effects on these variables into account. This can be done by careful recording of daily activities through diaries in combination with a movement detector and coregistration of respiratory behavior and ECG.

REFERENCES

- Allen, M. T., & Crowell, M. D. (1989). Patterns of autonomic response during laboratory stressors. *Psychophysiology*, *26*, 603–614.
- Berntson, G. G., Bigger, J. T., Eckberg, D. L., Grossman, P., Kaufmann, P. G., Malik, M., et al. (1997). Heart rate variability: Origins, methods, and interpretative caveats. *Psychophysiology*, *34*, 623–648.
- Berntson, G. G., Cacioppo, J. T., & Quigley, K. S. (1993). Respiratory sinus arrhythmia: Autonomic origins, physiological mechanisms, and psychophysiological implications. *Psychophysiology*, *30*, 183–196.
- Boudoulas, H., Barrington, W., Olson, S. M., Bashore, T. M., & Wooley, C. F. (1985). Effect of acute standing and prolonged upright activity on left ventricular hemodynamics, systolic and diastolic intervals, and QT-QS2 relationship. *American Heart Journal*, *110*, 623–630.
- Burgess, H. J., Penev, P. D., Schneider, R., & van Cauter, E. (2004). Estimating cardiac autonomic activity during sleep: Impedance cardiography, spectral analysis, and Poincaré plots. *Clinical Neurophysiology*, *115*, 19–28.
- Cacioppo, J. T., Berntson, G. G., Binkley, P. F., Quigley, K. S., Uchino, B. N., & Fieldstone, A. (1994). Autonomic cardiac control. II. Non-invasive indices and basal response as revealed by autonomic blockades. *Psychophysiology*, *31*, 586–598.
- Cacioppo, J. T., Uchino, B. N., & Berntson, G. G. (1994). Individual differences in the autonomic origins of heart rate reactivity: The psychometrics of respiratory sinus arrhythmia and pre-ejection period. *Psychophysiology*, *31*, 412–419.
- Chae, E. U., & Suh, Y. S. (1993). Hemodynamic responses to passive body tilts. *The Physiologist*, *36*(Suppl. 1), S20–S21.
- Cooke, W. H., Hoag, J. B., Crossman, A. A., Kuusela, T. A., Tahvanainen, K. U., & Eckberg, D. L. (1999). Human responses to upright tilt: A window on central autonomic integration. *Journal of Physiology*, *517*, 617–628.
- Cybulski, G. (2000). Ambulatory impedance cardiography: New possibilities. *Journal of Applied Physiology*, *88*, 1509–1510.
- Doornen, L. J. P. van, Snieder, H., & Boomsma, D. I. (1998). Serum lipids and cardiovascular reactivity to stress. *Biological Psychology*, *47*, 279–297.
- Eckberg, D. L. (2003). The human respiratory gate. *Journal of Physiology*, *548*, 339–352.
- Eekelen, A. P. van, Houtveen, J. H., & Kerkhof, G. A. (2004). Circadian variation in cardiac autonomic activity: Reactivity measurements to different types of stressors. *Chronobiological International*, *21*, 107–129.
- Ermis, C., Samniah, N., Sakaguchi, S., Lurie, K. G., Pham, S., Lu, F., et al. (2004). Comparison of catecholamine response during tilt-table-induced vasovagal syncope in patients <35 to those >65 years of age. *American Journal of Cardiology*, *93*, 225–227.
- Esler, M., Jennings, G., Korner, P., Willett, I., Dudley, F., Hasking, G., et al. (1988). Assessment of human sympathetic nervous system activity from measurements of norepinephrine turnover. *Hypertension*, *11*, 3–20.
- Frey, M. A., & Kenney, R. A. (1979). Systolic time intervals during combined hand cooling and head-up tilt. *Aviation, Space, and Environmental Medicine*, *50*, 218–222.
- Frey, M. A., Tomaselli, C. M., & Hoffer, W. G. (1994). Cardiovascular responses to postural changes: Differences with age for women and men. *Journal of Clinical Pharmacology*, *34*, 394–402.
- Furlan, R., Porta, A., Costa, F., Tank, J., Baker, L., Schiavi, R., et al. (2000). Oscillatory patterns in sympathetic neural discharge and cardiovascular variables during orthostatic stimulus. *Circulation*, *101*, 886–892.
- Geus, E. J. C. de, & Doornen, L. J. P. van. (1996). Ambulatory assessment of parasympathetic/sympathetic balance by impedance cardiography. In J. Fahrenberg & M. Myrtek (Eds.), *Ambulatory assessment* (pp. 141–163). Seattle: Hogrefe & Huber Publishers.
- Geus, E. J. C. de, Willemsen, G. H. M., Klaver, C. H. A. M., & Doornen, L. J. P. van. (1995). Ambulatory measurement of respiratory sinus arrhythmia and respiration rate. *Biological Psychology*, *41*, 205–227.
- Grossman, P., & Kollai, M. (1993). Respiratory sinus arrhythmia, cardiac vagal tone, and respiration: Within- and between-individual relations. *Psychophysiology*, *30*, 486–495.
- Grossman, P., van Beek, J., & Wientjes, C. (1990). A comparison of three quantification methods for estimation of respiratory sinus arrhythmia. *Psychophysiology*, *27*, 702–714.
- Grossman, P., Wilhelm, F. H., & Spoerle, M. (2004). Respiratory sinus arrhythmia, cardiac vagal control, and daily activity. *American Journal of Physiology: Heart Circulation Physiology*, *287*, 728–734.
- Houtveen, J. H., Groot, P. F. C., & Geus, E. J. C. de. (2005, May 10 [Epub ahead of print]). Validation of the thoracic impedance derived respiratory signal using multilevel analysis. *International Journal of Psychophysiology*.
- Houtveen, J. H., Rietveld, S., & Geus, E. J. C. de. (2002). Contribution of tonic vagal modulation of heart rate, central respiratory drive, respiratory depth, and respiratory frequency to respiratory sinus arrhythmia during mental stress and physical exercise. *Psychophysiology*, *39*, 427–436.
- Keenan, D. B. (2004). Continuous monitoring of cardiac output from TCG signals. *Biomedical Science Instruments*, *40*, 343–349.
- Krzeminski, K., Kruk, B., Nazar, K., Ziemba, A. W., Cybulski, G., & Niewiadomski, W. (2000). Cardiovascular, metabolic and plasma catecholamine responses to passive and active exercises. *Journal of Physiology and Pharmacology*, *51*, 267–278.
- Laszlo, Z., Rossler, A., & Hinghofer-Szalkay, H. G. (2001). Cardiovascular and hormonal changes with different angles of head-up tilt in men. *Physiological Research*, *50*, 71–82.
- Lewis, R. P., Rittogers, S. E., Forester, W. F., & Boudoulas, H. (1977). A critical review of the systolic time intervals. *Circulation*, *56*, 146–158.
- Matsumura, R., Tanaka, H., & Tamai, H. (2004). Comparison of the active standing test and head-up tilt test for diagnosis of syncope in childhood and adolescence. *Clinical Autonomic Research*, *14*, 376–384.
- Mezzacappa, E. S., Kelsey, R. M., & Katkin, E. S. (1999). The effects of epinephrine administration on impedance cardiographic measures of cardiovascular function. *International Journal of Psychophysiology*, *31*, 189–196.
- Montoya, P., Brody, S., Beck, K., Veit, R., & Rau, H. (1997). Differential beta- and alpha-adrenergic activation during psychological stress. *European Journal of Applied Physiology and Occupational Physiology*, *75*, 256–262.
- Mukai, S., & Hayano, J. (1995). Heart rate and blood pressure variabilities during graded head-up tilt. *Journal of Applied Physiology*, *78*, 212–216.
- Newlin, D. B., & Levenson, R. W. (1979). Pre-ejection period: Measuring β -adrenergic influences upon the heart. *Psychophysiology*, *16*, 546–553.
- Ovadia, M., Gear, K., Thoele, D., & Marcus, F. I. (1995). Accelerometer systolic time intervals as fast-response sensors of upright posture in the young. *Circulation*, *92*, 1849–1859.
- Penttilä, J., Helminen, A., Jartti, T., Kuusela, T., Huikuri, H. V., Tulppo, M. P., et al. (2001). Time domain, geometrical and frequency domain analysis of cardiac vagal outflow: Effects of various respiratory patterns. *Clinical Physiology*, *21*, 365–376.
- Riese, H., Doornen, L. J. P. van, Houtman, I. L., & Geus, E. J. C. de. (2004). Job strain in relation to ambulatory blood pressure, heart rate, and heart rate variability among female nurses. *Scandinavian Journal of Work Environmental Health*, *30*, 477–485.
- Saito, M., Foldager, N., Mano, T., Iwase, S., Sugiyama, Y., & Oshima, M. (1997). Sympathetic control of hemodynamics during moderate head-up tilt in human subjects. *Environmental Medicine*, *41*, 151–155.

- Sasano, N., Vesely, A. E., Hayano, J., Sasano, H., Somogyi, R., Preiss, D., et al. (2002). Direct effect of Pa(CO₂) on respiratory sinus arrhythmia in conscious humans. *American Journal of Physiology: Heart Circulation Physiology*, 282, 973–976.
- Shannon, R. P., Maher, K. A., Santinga, J. T., Royal, H. D., & Wei, J. Y. (1991). Comparison of differences in the hemodynamic response to passive postural stress in healthy subjects greater than 70 years and less than 30 years of age. *American Journal of Cardiology*, 67, 1110–1116.
- Sherwood, A., Allen, M. T., Fahrenberg, J., Kelsey, R. M., Lovallo, W. R., & Doornen, L. J. P. van. (1990). Methodological guidelines for impedance cardiography. *Psychophysiology*, 27, 1–23.
- Sherwood, A., Allen, M. T., Obrist, P. A., & Langer, A. W. (1986). Evaluation of β -adrenergic influences on cardiovascular and metabolic adjustments to physical and psychological stress. *Psychophysiology*, 23, 89–104.
- Sherwood, A., McFetridge, J., & Hutcheson, J. S. (1998). Ambulatory impedance cardiography: A feasibility study. *Journal of Applied Physiology*, 85, 2365–2369.
- Sherwood, A., & Turner, J. R. (1993). Postural stability of hemodynamic responses during mental challenge. *Psychophysiology*, 30, 237–244.
- Shoemaker, J. K., Hogeman, C.S., Khan, M., Kimmerly, D. S., & Sinoway, L. I. (2001). Gender affects sympathetic and hemodynamic response to postural stress. *American Journal of Physiology: Heart Circulation Physiology*, 81, 2028–2035.
- Siebert, J., Drabik, P., Lango, R., & Szyndler, K. (2004). Stroke volume variability and heart rate power spectrum in relation to posture changes in healthy subjects. *Medical Science Monitor*, 10, MT31–37.
- Smith, J. J., Muzi, M., Barney, J. A., Ceschi, J., Hayes, J., & Ebert, T. J. (1989). Impedance-derived cardiac indices in supine and upright exercise. *Annual Biomedical Engineering*, 17, 507–515.
- Svedenhag, J., Martinsson, A., Ekblom, B., & Hjerdahl, P. (1986). Altered cardiovascular responsiveness to adrenaline in endurance-trained subjects. *Acta Physiologica Scandinavica*, 126, 539–550.
- Toska, K., & Walloe, L. (2002). Dynamic time course of hemodynamic responses after passive head-up tilt and tilt back to supine position. *Journal of Applied Physiology*, 92, 1671–1676.
- Trinder, J., Kleiman, J., Carrington, M., Smith, S., Breen, S., Tan, N., et al. (2001). Autonomic activity during human sleep as a function of time and sleep stage. *Journal of Sleep Research*, 10, 253–264.
- Vijayalakshmi, P., Mohan, M., & Babu, P. B. (2002). Effect of 60 degrees head-up tilt on systolic time intervals in hypertensive patients. *Indian Journal of Physiological Pharmacology*, 46, 45–50.
- Vrijkotte, T. G. M., Doornen, L. J. P. van, & Geus, E. J. C. de. (2004). Overcommitment to work is associated with changes in cardiac sympathetic regulation. *Psychosomatic Medicine*, 66, 656–663.
- Waldstein, S. R., Neumann, S. A., & Merrill, J. A. (1998). Postural effects on hemodynamic response to interpersonal interaction. *Biological Psychology*, 48, 57–67.
- Willemsen, G. H. M., Geus, E. J. C. de, Klaver, C. H. A. M., Doornen, L. J. P. van, & Carroll, D. (1996). Ambulatory monitoring of the impedance cardiogram. *Psychophysiology*, 33, 184–193.

(RECEIVED March 1, 2005; ACCEPTED August 23, 2005)